

Application Note: Precision Synthesis and Polymerization of Thiophene Derivatives

Author: BenchChem Technical Support Team. **Date:** February 2026

Compound of Interest

Compound Name: 2,5-Bis(dimethylsilyl)thiophene

CAS No.: 23395-60-0

Cat. No.: B1611043

[Get Quote](#)

Abstract

This guide provides a rigorous experimental framework for the polymerization of thiophene derivatives, specifically focusing on Poly(3-hexylthiophene) (P3HT) as the benchmark material. [1] While thiophene-based polymers are staples in organic electronics (OFETs, OPVs), their emerging role in bioelectronics and drug delivery scaffolds demands higher purity and structural definition than standard industrial grades.

This document details three distinct protocols:

- Grignard Metathesis (GRIM): For high-regioregularity and defined molecular weight (critical for drug carriers).
- Chemical Oxidative Polymerization: For scalable, bulk synthesis of conductive scaffolds.
- Electropolymerization: For direct coating of biosensors and neural interfaces.

Part 1: Strategic Method Selection

Before initiating synthesis, select the method based on the required material properties.

Feature	GRIM (Kumada Transfer)	Oxidative (FeCl ₃)	Electropolymerization
Primary Application	Drug delivery vectors, High-performance electronics	Bulk conductive hydrogels, Tissue scaffolds	Biosensor coatings, Neural electrodes
Regioregularity (HT)	Very High (>98%)	Low to Moderate (50-80%)	Variable (Solvent dependent)
Molecular Weight (MW)	Controlled (Living nature)	High, but broad distribution (PDI > 2)	Insoluble films (Cross-linked)
Scalability	Moderate (g to kg)	High (kg to ton)	Low (mg / Surface only)
Key Challenge	Stoichiometric precision required	Purification (Iron removal)	Surface adhesion & morphology

Part 2: Grignard Metathesis (GRIM) Polymerization

Objective: Synthesis of Head-to-Tail (HT) Regioregular P3HT with low polydispersity (PDI < 1.2). Mechanism: Nickel-catalyzed chain-growth polycondensation.[2]

Reagents & Setup

- Monomer: 2,5-dibromo-3-hexylthiophene (Must be >99% pure by GC-MS).
- Catalyst: Ni(dppp)Cl₂ (Nickel(II) bis(diphenylphosphino)propane dichloride).
- Grignard Reagent: tert-Butylmagnesium chloride (2.0 M in THF).
- Solvent: Anhydrous THF (distilled over Na/benzophenone or from SPS).
- Atmosphere: Nitrogen or Argon (Glovebox or Schlenk line).

Experimental Protocol

Step 1: Grignard Exchange (The Critical Step)

- Dissolve 2,5-dibromo-3-hexylthiophene (1 eq) in anhydrous THF.
- Add t-BuMgCl (0.98 eq) dropwise at room temperature.
 - Expert Insight: Never use 1.0 eq or excess. Excess Grignard will kill the Ni catalyst. Using 0.98 eq ensures the monomer is the limiting reagent for the exchange, leaving a small amount of dibromo species which is inert to the catalyst initiation but harmless.
- Stir for 30–60 minutes.

Self-Validating Check (NMR): Take a 0.1 mL aliquot, quench with D₂O/HCl. Analyze via ¹H NMR.

- Pass: The doublet at ~6.9 ppm (3-proton of starting material) should shift/disappear.
- Fail: If significant starting material remains, the exchange is incomplete.

Step 2: Polymerization^{[3][4][5]}

- Add Ni(dppp)Cl₂ (0.005 – 0.02 eq depending on target MW) dissolved in minimal THF.
- Stir at room temperature. The solution will turn from yellow/orange to dark purple/black within seconds.
- Allow to react for 30 minutes (conversion is typically fast).

Step 3: Quenching & Precipitation

- Pour the reaction mixture into a 10x volume of methanol containing 2N HCl (to protonate the chain ends and remove Mg salts).
- Filter the dark solid.

Mechanistic Workflow (GRIM)

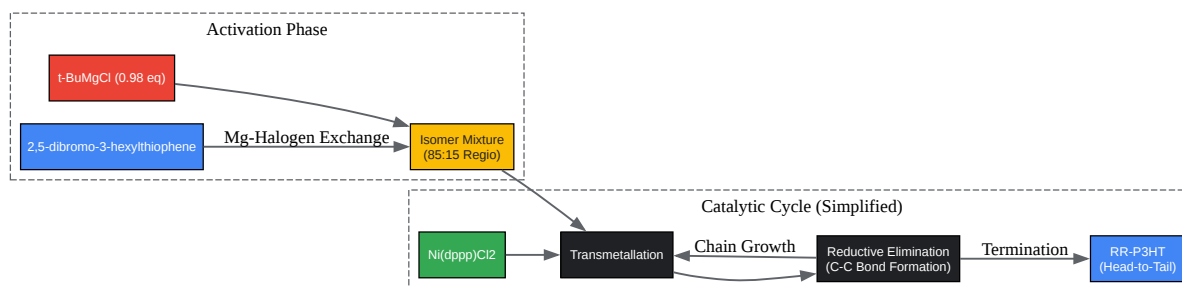

[Click to download full resolution via product page](#)

Caption: GRIM polymerization workflow highlighting the critical activation stoichiometry and nickel-catalyzed chain growth.

Part 3: Chemical Oxidative Polymerization (FeCl₃)

Objective: Large-scale synthesis of conductive thiophene scaffolds where regioregularity is secondary to yield and cost.

Reagents & Setup

- Oxidant: Anhydrous FeCl₃ (Must be stored in a desiccator; hydration kills the reaction).
- Solvent: Chloroform or Chlorobenzene (dry).
- Monomer: 3-hexylthiophene.^{[1][3][4][5][6][7][8]}

Experimental Protocol (Reverse Addition Method)

Expert Insight: Standard addition (adding FeCl₃ to monomer) often leads to cross-linking and insolubility. Reverse addition (adding monomer to FeCl₃ slurry) controls the radical concentration and improves solubility.

- Suspension: Suspend anhydrous FeCl_3 (4.0 eq) in dry chloroform under Argon.
- Addition: Dissolve monomer (1.0 eq) in chloroform. Add dropwise to the FeCl_3 suspension over 1 hour.
- Reaction: Stir for 24 hours at room temperature.
- Reduction: The polymer is currently in its oxidized (doped) state. Pour into Methanol to precipitate.^{[5][9]}
- Dedoping: To process the material, you must remove the iron and dedope. Boil the polymer in Hydrazine/Methanol or wash extensively with Methanol/Ammonia.

Self-Validating Check (Solubility):

- Take a small sample of the dried polymer and attempt to dissolve in Chloroform.
- Pass: Fully soluble deep orange solution.
- Fail: Presence of black "gel" particles indicates cross-linking (likely due to high temperature or fast addition).

Part 4: Electropolymerization

Objective: Direct deposition of polythiophene films onto conductive substrates (ITO, Gold, Platinum) for sensors.

Reagents & Setup

- Electrolyte: 0.1 M LiClO_4 or TBAPF_6 in Acetonitrile (ACN) or Dichloromethane (DCM).
 - Note: ACN yields compact films; DCM yields looser, more porous films.
- Monomer: 10–50 mM Thiophene derivative.
- Reference Electrode: Ag/AgCl (aqueous) or Ag/Ag^+ (non-aqueous).

Experimental Protocol (Potentiodynamic)

- Cell Setup: Use a standard 3-electrode cell.
- Cleaning: Sonicate working electrode (e.g., ITO) in Acetone -> Isopropanol -> Water. Plasma clean if available.
- Deposition: Cycle voltage between -0.2 V and +1.5 V (vs Ag/AgCl).
 - Critical Limit: Do not exceed +1.6 V. Overoxidation degrades the polymer conjugation, destroying conductivity.
- Growth: Observe the increase in current with each cycle (indicating conductive film growth).

Electrochemical Setup Diagram

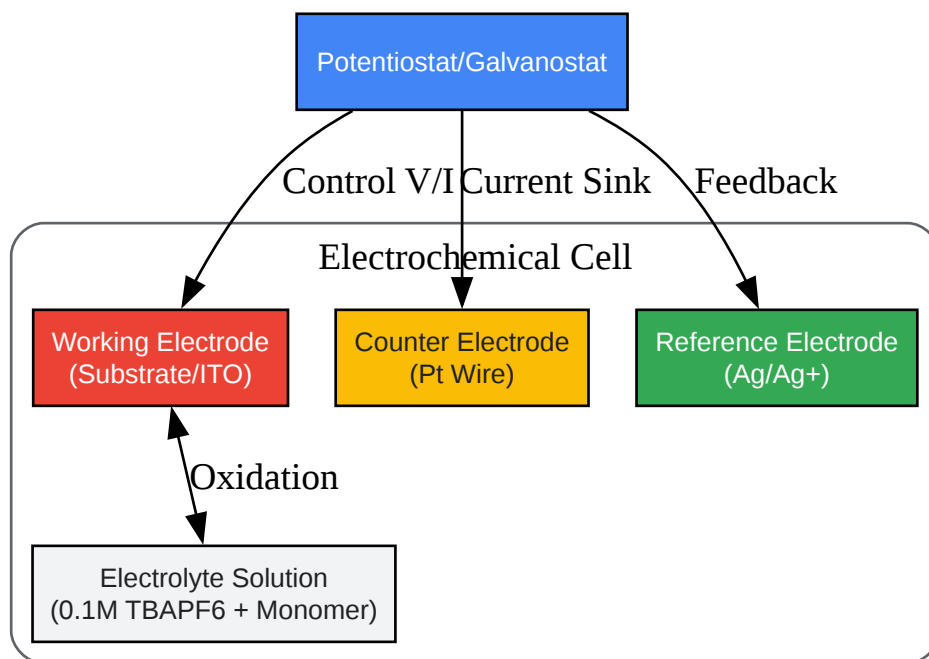

[Click to download full resolution via product page](#)

Caption: Three-electrode setup for controlled electropolymerization. The Working Electrode acts as the substrate for film growth.

Part 5: Purification & Characterization (Soxhlet Extraction)

Regardless of the synthesis method, purification is the single most important step for biological applications to remove toxic monomers and oligomers.

Protocol: Sequential Soxhlet Extraction

- Load crude polymer into a cellulose thimble.
- Fraction 1 (Methanol): Run for 12 hours. Removes salts, catalyst residues, and monomer.
- Fraction 2 (Hexanes): Run for 12 hours. Removes low MW oligomers (grease).
- Fraction 3 (Chloroform): Run until the solvent in the siphon is clear. Collect this fraction. This is your high MW, high-quality polymer.

Data Presentation: Typical Characterization Values

Parameter	Method	Target Value (High Quality)
Regioregularity	¹ H NMR (Integrate HT vs HH peaks)	> 95% (GRIM)
Molecular Weight (Mn)	GPC (vs Polystyrene)	20 – 50 kDa
Polydispersity (PDI)	GPC (Mw/Mn)	1.1 – 1.4 (GRIM); 2.0+ (FeCl ₃)
Optical Bandgap	UV-Vis (Solid State)	~1.9 eV (Absorption edge ~650nm)

References

- McCullough, R. D., et al. (1999). Grignard Metathesis Method (GRIM): Toward a Universal Method for the Synthesis of Conjugated Polymers.[\[10\]](#) *Macromolecules*.[\[1\]](#)[\[6\]](#)[\[8\]](#)[\[9\]](#)[\[10\]](#)[\[11\]](#)[\[12\]](#) [Link](#)
- Niemi, V. M., et al. (1992). Polymerization of 3-alkylthiophenes with FeCl₃.[\[13\]](#) *Polymer*.[\[1\]](#)[\[5\]](#)[\[6\]](#)[\[8\]](#)[\[9\]](#)[\[10\]](#)[\[11\]](#)[\[12\]](#)[\[14\]](#)[\[15\]](#) [Link](#)
- Roncali, J. (1992). Conjugated poly(thiophenes): synthesis, functionalization, and applications. *Chemical Reviews*. [Link](#)

- Jeffries-EL, M., et al. (2011). In-situ End-Group Functionalization of Regioregular Poly(3-hexylthiophene). *Macromolecules*.[\[1\]\[6\]\[8\]\[9\]\[10\]\[11\]\[12\]](#) [Link](#)
- EPA Method 3540C. (1996). Soxhlet Extraction.[\[11\]\[16\]\[17\]](#) US Environmental Protection Agency. [Link](#)

Need Custom Synthesis?

BenchChem offers custom synthesis for rare earth carbides and specific isotopic labeling.

Email: info@benchchem.com or [Request Quote Online](#).

Sources

- [1. iris.unito.it](http://iris.unito.it) [iris.unito.it]
- [2. chem.cmu.edu](http://chem.cmu.edu) [chem.cmu.edu]
- [3. researchgate.net](http://researchgate.net) [researchgate.net]
- [4. utd-ir.tdl.org](http://utd-ir.tdl.org) [utd-ir.tdl.org]
- [5. rsc.org](http://rsc.org) [rsc.org]
- [6. par.nsf.gov](http://par.nsf.gov) [par.nsf.gov]
- [7. researchgate.net](http://researchgate.net) [researchgate.net]
- [8. Preprocessing Affords 3D Crystalline Poly\(3-hexylthiophene\) Structure - PMC](http://pmc.ncbi.nlm.nih.gov) [pmc.ncbi.nlm.nih.gov]
- [9. Enabling Conducting Polymer Applications: Methods for Achieving High Molecular Weight in Chemical Oxidative Polymerization in Alkyl- and Ether-Substituted Thiophenes - PMC](http://pmc.ncbi.nlm.nih.gov) [pmc.ncbi.nlm.nih.gov]
- [10. pubs.acs.org](http://pubs.acs.org) [pubs.acs.org]
- [11. Synthesis and characterization of poly\(3-hexylthiophene\): improvement of regioregularity and energy band gap - RSC Advances \(RSC Publishing\) DOI:10.1039/C8RA00555A](http://pubs.rsc.org) [pubs.rsc.org]
- [12. mdpi.com](http://mdpi.com) [mdpi.com]
- [13. cpsm.kpi.ua](http://cpsm.kpi.ua) [cpsm.kpi.ua]
- [14. pubs.acs.org](http://pubs.acs.org) [pubs.acs.org]

- [15. openriver.winona.edu](https://openriver.winona.edu) [openriver.winona.edu]
- [16. epa.gov](https://epa.gov) [epa.gov]
- [17. hielscher.com](https://hielscher.com) [hielscher.com]
- To cite this document: BenchChem. [Application Note: Precision Synthesis and Polymerization of Thiophene Derivatives]. BenchChem, [2026]. [Online PDF]. Available at: [<https://www.benchchem.com/product/b1611043#experimental-setup-for-the-polymerization-of-thiophene-derivatives>]

Disclaimer & Data Validity:

The information provided in this document is for Research Use Only (RUO) and is strictly not intended for diagnostic or therapeutic procedures. While BenchChem strives to provide accurate protocols, we make no warranties, express or implied, regarding the fitness of this product for every specific experimental setup.

Technical Support: The protocols provided are for reference purposes. Unsure if this reagent suits your experiment? [[Contact our Ph.D. Support Team for a compatibility check](#)]

Need Industrial/Bulk Grade? [Request Custom Synthesis Quote](#)

BenchChem

Our mission is to be the trusted global source of essential and advanced chemicals, empowering scientists and researchers to drive progress in science and industry.

Contact

Address: 3281 E Guasti Rd

Ontario, CA 91761, United States

Phone: (601) 213-4426

Email: info@benchchem.com