

# Comparative Spectroscopic Profiling: N-(4-Iodo-phenyl)-guanidine

**Author:** BenchChem Technical Support Team. **Date:** April 2026

## Compound of Interest

Compound Name: *N*-(4-Iodo-phenyl)-guanidine

CAS No.: 45964-99-6

Cat. No.: B1610067

[Get Quote](#)

## Executive Summary

This guide provides a definitive spectroscopic analysis of **N-(4-Iodo-phenyl)-guanidine** hydrochloride, a critical pharmacophore intermediate often utilized in the synthesis of kinase inhibitors and radiopharmaceuticals.

The primary challenge in characterizing aryl-guanidines lies in the proton exchange dynamics of the guanidinium core and the AA'BB' symmetry of the para-substituted aromatic ring. This guide objectively compares the product against its precursor, 4-Iodoaniline, to establish a robust "Pass/Fail" criterion for reaction monitoring.

**Key Technical Insight:** The conversion of the amine (-NH<sub>2</sub>) to the guanidinium (-NH-C(NH<sub>2</sub>)<sub>2</sub><sup>+</sup>) moiety results in a distinct deshielding of the ortho-protons (relative to nitrogen), shifting them from ~6.5 ppm (aniline) to ~7.0–7.2 ppm (guanidine). This shift is the primary indicator of successful synthesis.

## Comparative NMR Profiling (Precursor vs. Product)

The following table contrasts the  $^1\text{H}$  NMR spectral features of the starting material (4-Iodoaniline) and the product. This comparison serves as the primary quality control (QC) checkpoint.

Solvent: DMSO- $d_6$  (Required for observation of exchangeable protons) Frequency: 400 MHz[1]  
[2]

Spectral Feature	Precursor: 4-Iodoaniline	Product: N-(4-Iodo-phenyl)-guanidine HCl	Diagnostic Shift ( $\Delta\delta$ )
Aromatic H (Ortho to I)	~7.35 ppm (d, J=8.8 Hz)	~7.70 ppm (d, J=8.8 Hz)	+0.35 ppm (Deshielding)
Aromatic H (Ortho to N)	~6.45 ppm (d, J=8.8 Hz)	~7.05 ppm (d, J=8.8 Hz)	+0.60 ppm (Loss of strong shielding)
Exchangeable Protons	~5.20 ppm (br s, 2H, -NH <sub>2</sub> )	~9.60 ppm (s, 1H, -NH-Ar)~7.40 ppm (br s, 4H, -C(NH <sub>2</sub> ) <sub>2</sub> <sup>+</sup> )	Distinct Pattern Change
Symmetry System	AA'BB' (Strong roofing effect)	AA'BB' (Distinct doublets)	Preserved Symmetry

“

*Analyst Note: The dramatic downfield shift of the protons ortho to the nitrogen (from 6.45 to 7.05 ppm) confirms the conversion of the electron-donating free amine into the electron-withdrawing (cationic) guanidinium species.*

## Deep Dive: $^1\text{H}$ NMR Spectrum Analysis The Aromatic Region (AA'BB' System)

The molecule possesses a

axis of symmetry passing through the Iodine and the Nitrogen atoms. This creates two sets of chemically equivalent but magnetically non-equivalent protons.

- Signal A (Ortho to Iodine): Appears at ~7.70 ppm. Iodine is a heavy atom; while normally electronegative, its large electron cloud can induce complex shielding effects (heavy atom effect). However, in this system, the inductive withdrawal dominates relative to the rest of the ring, keeping these protons downfield.
- Signal B (Ortho to Guanidine): Appears at ~7.05 ppm. In the precursor aniline, the lone pair on the nitrogen donates density into the ring (resonance), heavily shielding these protons (pushing them upfield to ~6.5 ppm). Upon guanidinylation and protonation (HCl salt), this lone pair is involved in the guanidinium resonance system and is no longer available to shield the ring. Consequently, these protons shift downfield (deshielded).

## The Guanidine Region (Exchangeable Protons)

This region is strictly solvent-dependent.

- In DMSO- $d_6$ : You will observe a sharp singlet at ~9.60 ppm corresponding to the aryl-NH proton, and a broad signal (integral 4H) at ~7.40 ppm representing the terminal -NH<sub>2</sub> protons.
- In Methanol- $d_4$  / D<sub>2</sub>O: These signals will disappear completely due to rapid Deuterium exchange ( ).
  - Validation Tip: If you run the sample in CD<sub>3</sub>OD and still see peaks in this region, your solvent is "wet" or the exchange is incomplete.

## Experimental Protocols (Self-Validating Systems)

### Synthesis Protocol (Guanidinylation)

This protocol uses the cyanamide route, preferred for its atom economy and direct access to the salt form.

- Dissolution: Dissolve 4-Iodoaniline (1.0 eq) in 1,4-Dioxane (concentration 0.5 M).

- Acidification: Add 4M HCl in Dioxane (1.1 eq) dropwise. A white precipitate (aniline hydrochloride salt) will form.
- Addition: Add Cyanamide ( , 1.5 eq) as a solution in dioxane.
- Reflux: Heat the mixture to 90°C for 12 hours. The suspension will solubilize and then reprecipitate as the product forms.
- Isolation: Cool to room temperature. Filter the solid.[3][4]
- Purification (Critical): Wash the filter cake with cold Diethyl Ether (removes unreacted aniline) followed by cold Acetone (removes excess cyanamide).
- Drying: Vacuum dry at 40°C.

## Sample Preparation for NMR

To ensure reproducibility and prevent concentration-dependent shifts:

- Mass: Weigh 5–10 mg of the dry hydrochloride salt.
- Solvent: Add 0.6 mL of DMSO-d<sub>6</sub> (99.9% D).
- Homogenization: Sonicate for 30 seconds. Ensure the solution is perfectly clear.
- Reference: Calibrate the spectrum to the residual DMSO pentet at 2.50 ppm.

## Visualizations

### Synthesis & Workup Logic

This workflow illustrates the critical purification steps to ensure the NMR spectrum is free of precursor signals.

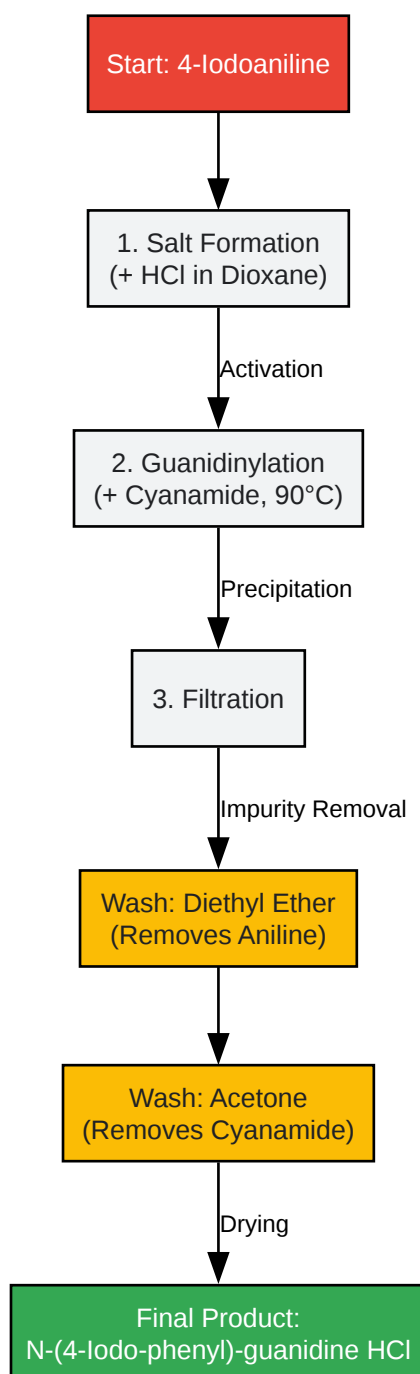

[Click to download full resolution via product page](#)

Figure 1: Step-by-step synthesis and purification workflow designed to minimize impurities in the final NMR spectrum.

## NMR Signal Assignment Logic

The following diagram details the splitting logic for the AA'BB' aromatic system.

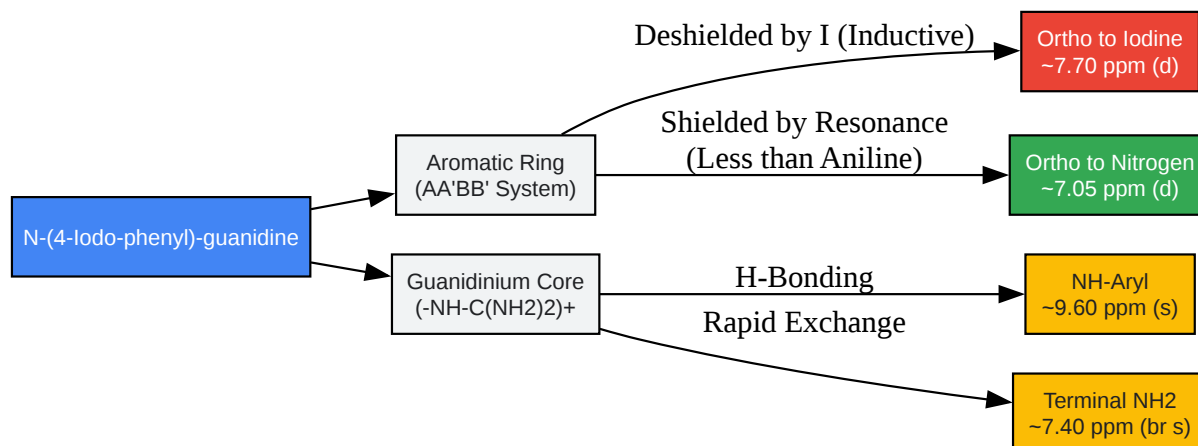

[Click to download full resolution via product page](#)

Figure 2: Logic tree for assigning  $^1\text{H}$  NMR signals based on electronic environments and substituent effects.

## References

- National Institutes of Health (NIH). (2016). A Direct, Early Stage Guanidinylation Protocol for the Synthesis of Complex Aminoguanidine-containing Natural Products. PMC. Retrieved from [\[Link\]](#)
- University of Wisconsin-Madison. (n.d.). Assigning the  $^1\text{H}$ -NMR Signals of Aromatic Rings: Substituent Effects. Retrieved from [\[Link\]](#)

### Need Custom Synthesis?

BenchChem offers custom synthesis for rare earth carbides and specific isotopic labeling.

Email: [info@benchchem.com](mailto:info@benchchem.com) or [Request Quote Online](#).

## Sources

- [1. rsc.org \[rsc.org\]](https://www.rsc.org)
- [2. X-ray Structure of Eleven New N,N'-Substituted Guanidines: Effect of Substituents on Tautomer Structure in the Solid State | MDPI \[mdpi.com\]](#)

- [3. Guanidine hydrochloride synthesis - chemicalbook \[chemicalbook.com\]](#)
- [4. A Direct, Early Stage Guanidinylation Protocol for the Synthesis of Complex Aminoguanidine-containing Natural Products - PMC \[pmc.ncbi.nlm.nih.gov\]](#)
- To cite this document: BenchChem. [Comparative Spectroscopic Profiling: N-(4-Iodo-phenyl)-guanidine]. BenchChem, [2026]. [Online PDF]. Available at: [<https://www.benchchem.com/product/b1610067/docs#comparative-spectroscopic-profiling-n-4-iodo-phenyl-guanidine>]

---

### Disclaimer & Data Validity:

The information provided in this document is for Research Use Only (RUO) and is strictly not intended for diagnostic or therapeutic procedures. While BenchChem strives to provide accurate protocols, we make no warranties, express or implied, regarding the fitness of this product for every specific experimental setup.

**Technical Support:** The protocols provided are for reference purposes. Unsure if this reagent suits your experiment?

**Need Industrial/Bulk Grade?** [Request Custom Synthesis Quote](#)

## BenchChem

Our mission is to be the trusted global source of essential and advanced chemicals, empowering scientists and researchers to drive progress in science and industry.

### Contact

Address: 3281 E Guasti Rd  
Ontario, CA 91761, United States  
Phone: (601) 213-4426  
Email: [info@benchchem.com](mailto:info@benchchem.com)

[Contact our Ph.D. Support Team for a compatibility check](#)

