

# Application Notes & Protocols: Asymmetric Hydrogenation for Stereoselective Synthesis

**Author:** BenchChem Technical Support Team. **Date:** May 2026

## Compound of Interest

Compound Name: 2,6-Piperidinedione, 3-amino-,  
(3S)-

CAS No.: 29883-25-8

Cat. No.: B1610023

[Get Quote](#)

A Senior Application Scientist's Guide for Researchers and Drug Development Professionals

## Foreword: Precision in Three Dimensions

The synthesis of single-enantiomer compounds is a cornerstone of modern chemistry, particularly within the pharmaceutical and life sciences industries. The differential physiological effects of enantiomers necessitate precise control over stereochemistry during synthesis. Among the methodologies developed to achieve this, asymmetric hydrogenation stands out for its elegance, efficiency, and atom economy.[1][2] This technique, which introduces two hydrogen atoms across an unsaturated bond with a high degree of facial selectivity, allows for the direct creation of chiral centers from prochiral substrates.[3][4]

The pioneering work of Knowles and Noyori, recognized with the 2001 Nobel Prize in Chemistry, laid the foundation for the industrial application of this technology, most notably in the synthesis of L-DOPA.[2][5] Since then, the field has expanded dramatically, with the development of a vast arsenal of chiral catalysts capable of reducing a wide array of functional groups with exceptional enantioselectivity.[3]

This document serves as a comprehensive guide for researchers, scientists, and drug development professionals. It moves beyond a simple recitation of procedures to provide a deeper understanding of the principles governing catalyst selection, reaction optimization, and mechanistic pathways. Our goal is to empower you to not only apply existing protocols but also to innovate and troubleshoot effectively in your own stereoselective syntheses.

## The Foundation: Principles of Asymmetric Hydrogenation

Asymmetric hydrogenation leverages a chiral catalyst to create a diastereomeric transition state with the prochiral substrate. The energy difference between these two transition states dictates the enantiomeric excess (e.e.) of the product. The most successful catalysts are typically transition metal complexes featuring chiral ligands.<sup>[3][4]</sup>

Key Catalyst Components:

- **Metal Center:** Ruthenium (Ru), Rhodium (Rh), and Iridium (Ir) are the most commonly employed metals due to their catalytic activity and ability to coordinate with a variety of ligands.<sup>[3]</sup> More recently, first-row transition metals are being explored as more sustainable alternatives.<sup>[6]</sup>
- **Chiral Ligands:** These are the primary source of chirality in the catalyst. Bidentate phosphine ligands, such as BINAP and DuPhos, have been instrumental in the field.<sup>[4]</sup> The C<sub>2</sub>-symmetry of many of these ligands simplifies the number of possible diastereomeric transition states, often leading to higher enantioselectivity.
- **Substrate:** The nature of the substrate (e.g., ketones, olefins, imines) and the presence of coordinating functional groups heavily influence catalyst choice and reaction conditions.<sup>[3][7]</sup>

## The Workhorses: A Survey of Catalyst Systems

The choice of catalyst is paramount for achieving high enantioselectivity and turnover numbers (TON). Below is a summary of some of the most influential and versatile catalyst systems.

### Homogeneous Catalysts

Homogeneous catalysts, which operate in the same phase as the reactants, offer high activity and selectivity due to their well-defined molecular structures.

Catalyst System	Metal	Key Ligand(s)	Typical Substrates	Key Features & Applications
Noyori's Ru-BINAP	Ru(II)	BINAP	Ketones, functionalized olefins	Nobel Prize-winning catalyst; widely used in industry for synthesis of antibiotics and anti-inflammatory drugs like Naproxen.[8][9]
Rh-DIPAMP	Rh(I)	DIPAMP	Dehydroamino acids	First industrial application for L-DOPA synthesis.[2][5]
Ir-JosiPhos	Ir(I)	JosiPhos	Imines	Used in the large-scale production of the herbicide (S)-metolachlor.[5]
Ru-Diamine/Diphosphine	Ru(II)	Diamine & Diphosphine	Simple ketones	"Bifunctional" catalysts where both the metal and the amine ligand participate in the reaction.[1][4]
Ir-P,N Ligands	Ir(I)	Phosphine-Oxazoline (PHOX)	Unfunctionalized olefins	Effective for substrates lacking a coordinating group.[3]

## Heterogeneous Catalysts

While homogeneous catalysts dominate the field, heterogeneous systems offer significant advantages in terms of catalyst separation and recycling.[10][11] A common approach involves the chiral modification of a metal surface, such as the use of cinchona alkaloids on platinum for the hydrogenation of  $\alpha$ -ketoesters.[10] Immobilization of homogeneous catalysts on solid supports is another strategy to bridge the gap between the two approaches.[10]

## Unveiling the "How": Mechanistic Insights

Understanding the reaction mechanism is crucial for rational catalyst design and optimization. The catalytic cycles, while varying between systems, share common fundamental steps.

### The Noyori Ru-BINAP/Diamine Mechanism for Ketone Hydrogenation

The Noyori bifunctional catalyst for ketone hydrogenation operates through a concerted, outer-sphere mechanism.[4] This mechanism is distinct from many others in that the substrate does not directly coordinate to the metal center.

- **Catalyst Activation:** The precatalyst, often a Ru(II) dihalide complex, is activated by hydrogen in the presence of a base to form the active dihydride species,  $\text{RuH}_2(\text{BINAP})(\text{diamine})$ .[4][12]
- **Outer-Sphere Interaction:** The active catalyst forms a six-membered pericyclic transition state with the ketone substrate.[4] A key feature is the simultaneous interaction of the Ru-H with the carbonyl carbon and the N-H of the diamine ligand with the carbonyl oxygen. This "bifunctional" nature is believed to be the source of its high reactivity.[4]
- **Hydride Transfer:** Hydrogen is transferred to the ketone, forming the chiral alcohol.
- **Product Release and Regeneration:** The alcohol product is released, and the catalyst is regenerated to continue the cycle.

Below is a diagram illustrating the key transition state in the Noyori bifunctional mechanism.

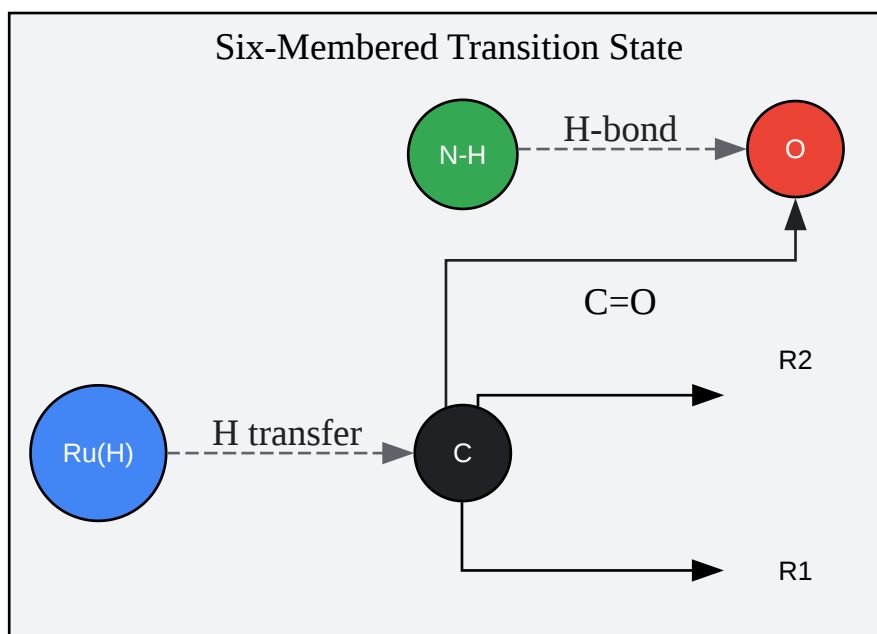

[Click to download full resolution via product page](#)

Caption: Noyori bifunctional transition state.

## From Theory to Practice: Detailed Experimental Protocols

The following protocols are designed to be robust starting points for your research. Always conduct reactions in a well-ventilated fume hood and use appropriate personal protective equipment.

### Protocol 1: General Procedure for Asymmetric Hydrogenation of an Aromatic Ketone

This protocol is a general method for the screening and optimization of the asymmetric hydrogenation of a prochiral aromatic ketone using a Ru-based catalyst.

Materials:

- Chiral Ruthenium precatalyst (e.g.,  $\text{RuCl}_2[(S)\text{-BINAP}]_2$ )
- Chiral diamine ligand (e.g., (S,S)-DPEN)

- Prochiral aromatic ketone (e.g., acetophenone)
- Anhydrous isopropanol (or other suitable alcohol solvent)
- Potassium tert-butoxide (KOtBu)
- High-pressure reactor (e.g., Parr shaker) equipped with a glass liner, magnetic stir bar, and gas inlet.
- Schlenk line or glovebox for inert atmosphere manipulation.

#### Procedure:

- Reactor Preparation: Ensure the high-pressure reactor is clean and dry. Place the glass liner and a magnetic stir bar inside.
- Catalyst Preparation (in a glovebox or under inert atmosphere):
  - To a Schlenk flask, add the Ru precatalyst (e.g., 0.001 mmol, 0.1 mol%) and the chiral diamine ligand (e.g., 0.0012 mmol, 0.12 mol%).
  - Add anhydrous isopropanol (2 mL) and stir for 15-30 minutes to form the catalyst precursor.
- Reaction Setup:
  - In a separate vial, dissolve the aromatic ketone (1.0 mmol) and KOtBu (0.02 mmol, 2 mol%) in anhydrous isopropanol (3 mL).
  - Transfer the substrate solution to the glass liner in the reactor.
  - Using a cannula, transfer the prepared catalyst solution to the reactor.
- Hydrogenation:
  - Seal the reactor and purge with hydrogen gas 3-5 times.
  - Pressurize the reactor to the desired pressure (e.g., 8 atm H<sub>2</sub>).

- Stir the reaction mixture at the desired temperature (e.g., 30 °C) for the specified time (e.g., 12 hours).
- Work-up and Analysis:
  - Carefully vent the reactor and purge with nitrogen.
  - Take an aliquot of the reaction mixture for analysis.
  - Determine the conversion by GC or <sup>1</sup>H NMR.
  - Determine the enantiomeric excess (e.e.) by chiral HPLC or GC.

## Protocol 2: High-Throughput Screening (HTS) of Ligands

For rapid catalyst discovery, a high-throughput screening approach is invaluable.<sup>[13][14]</sup> This protocol outlines a conceptual workflow for screening a library of chiral ligands.

Workflow:

- Plate Preparation: In a 96-well plate within a glovebox, dispense stock solutions of the metal precursor (e.g., [Rh(COD)<sub>2</sub>]BF<sub>4</sub>) to each well.
- Ligand Addition: Add a different chiral ligand from a pre-prepared library to each well.
- Substrate Addition: Add a stock solution of the prochiral substrate to each well.
- Reaction Execution: Place the 96-well plate into a parallel high-pressure reactor system. Pressurize with hydrogen and heat to the desired temperature.
- Quenching and Analysis: After the reaction time, vent the reactor. Quench the reactions and analyze each well using a rapid analytical technique such as chiral GC-MS or LC-MS to determine conversion and e.e.

The diagram below outlines the HTS workflow.

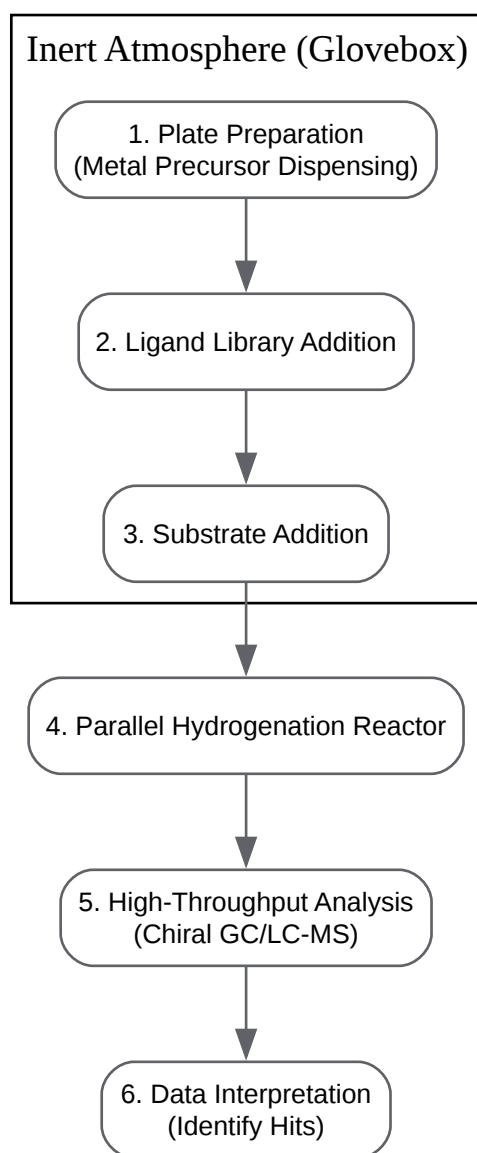

[Click to download full resolution via product page](#)

Caption: High-throughput screening workflow.

## Troubleshooting Common Issues

Issue	Possible Cause(s)	Suggested Solution(s)
Low Conversion	- Inactive catalyst- Insufficient H <sub>2</sub> pressure or temperature- Catalyst poisoning (e.g., by water, oxygen, or impurities in the substrate)	- Prepare fresh catalyst- Increase pressure/temperature systematically- Use anhydrous solvents and purify the substrate
Low Enantioselectivity	- Suboptimal ligand-substrate match- Incorrect catalyst-to-ligand ratio- Racemization of product under reaction conditions	- Screen a wider range of ligands- Optimize the metal:ligand stoichiometry- Reduce reaction time or temperature
Poor Reproducibility	- Inconsistent inert atmosphere technique- Variations in solvent/reagent quality- Inaccurate measurement of catalyst loading	- Ensure rigorous exclusion of air and moisture- Use fresh, high-purity reagents- Prepare catalyst stock solutions for accurate dispensing

## Conclusion and Future Outlook

Asymmetric hydrogenation is a mature and powerful tool for stereoselective synthesis.<sup>[3]</sup> The continued development of novel ligands and catalysts, including those based on earth-abundant metals, promises to further expand the scope and applicability of this technology.<sup>[6]</sup> The integration of high-throughput experimentation and computational modeling is accelerating the discovery of new catalytic systems for increasingly complex synthetic challenges.<sup>[14]</sup> For professionals in drug development, a deep understanding of asymmetric hydrogenation is not just advantageous—it is essential for the efficient and sustainable production of chiral molecules that shape modern medicine.

## References

- Asymmetric Hydrogenation Methods for the Synthesis of Chiral Molecules. (URL: )
- Noyori Hydrogen
- IR spectroscopy as a high-throughput screening-technique for enantioselective hydrogen-transfer catalysts - Chemical Communic
- Recent Progress in Heterogeneous Asymmetric Hydrogenation of C O and C C Bonds on Supported Noble Metal C

- Noyori Asymmetric Hydrogenation | Thermo Fisher Scientific - US. (URL: [\\_](#))
- IR spectroscopy as a high-throughput screening-technique for enantioselective hydrogen-transfer c
- High-throughput and parallel screening methods in asymmetric hydrogen
- Probing machine learning models based on high throughput experimentation data for the discovery of asymmetric hydrogenation c
- Noyori Asymmetric Hydrogenation | Chem-St
- Asymmetric hydrogen
- Asymmetric hydrogenation catalyzed by first-row transition metal complexes - Chemical Society Reviews (RSC Publishing). (URL: [\)](#)
- High-Throughput and Parallel Screening Methods in Asymmetric Hydrogenation | Chemical Reviews - ACS Public
- Asymmetric arene hydrogenation: towards sustainability and applic
- Asymmetric hydrogenation of ketones: Tactics to achieve high reactivity, enantioselectivity, and wide scope - NIH. (URL: [\)](#)
- Asymmetric Hydrogenation of Olefins Using Chiral Crabtree-type Catalysts: Scope and Limitations | Chemical Reviews - ACS Public
- Asymmetric hydrogenation and transfer hydrogenation in the enantioselective synthesis of flavonoids - Organic Chemistry Frontiers (RSC Publishing). (URL: [\)](#)
- Mechanistic insight into NOYORI asymmetric hydrogenations - Chemical Communic
- Asymmetric catalytic hydrogenation. Design of new Ru catalysts and chiral ligands - SciSpace. (URL: [\)](#)
- Asymmetric hydrogenation c
  
- Modern Methods for Asymmetric Hydrogenation of Ketones - Organic Chemistry Portal. (URL: [\[Link\]](#))
  
- Asymmetric Hydrogenation of Ketones by Simple Alkane-Diyl-Based Ir(P,N,O)
  
- Catalytic asymmetric transfer hydrogenation of ketones: Recent advances - Universidad de Alicante. (URL: [\[Link\]](#))
  
- Industrial Asymmetric Hydrogenation Processes for Chiral Drug Substances. (URL: [\)](#)
  
- Asymmetric Hydrogenation of Ketones with Polymer-Supported Chiral 1,2-Diphenylethylenediamine | Organic Letters - ACS Publications. (URL: [\[Link\]](#))

- Pioneering Perspectives on Asymmetric Hydrogenation | Accounts of Chemical Research. (URL: [\[Link\]](#))
- Catalytic Homogeneous Asymmetric Hydrogenation: Successes and Opportunities | Organometallics - ACS Publications. (URL: [\[Link\]](#))
- Asymmetric Hydrogenations – The Monsanto L-Dopa Process - ResearchGate. (URL: [\[Link\]](#))
- Manufacture of Asymmetric Hydrogenation Catalysts | Pharmaceutical Technology. (URL: [\[Link\]](#))

### Need Custom Synthesis?

BenchChem offers custom synthesis for rare earth carbides and specific isotopic labeling.

Email: [info@benchchem.com](mailto:info@benchchem.com) or [Request Quote Online](#).

## Sources

- [1. Asymmetric hydrogenation of ketones: Tactics to achieve high reactivity, enantioselectivity, and wide scope - PMC \[pmc.ncbi.nlm.nih.gov\]](#)
- [2. ousar.lib.okayama-u.ac.jp \[ousar.lib.okayama-u.ac.jp\]](#)
- [3. Asymmetric Hydrogenation Methods for the Synthesis of Chiral Molecules \[ajchem-b.com\]](#)
- [4. Asymmetric hydrogenation - Wikipedia \[en.wikipedia.org\]](#)
- [5. pharmtech.com \[pharmtech.com\]](#)
- [6. Asymmetric hydrogenation catalyzed by first-row transition metal complexes - Chemical Society Reviews \(RSC Publishing\) \[pubs.rsc.org\]](#)
- [7. pubs.acs.org \[pubs.acs.org\]](#)
- [8. Noyori Asymmetric Hydrogenation | Thermo Fisher Scientific - JP \[thermofisher.com\]](#)
- [9. Noyori Asymmetric Hydrogenation | Chem-Station Int. Ed. \[en.chem-station.com\]](#)
- [10. pubs.acs.org \[pubs.acs.org\]](#)
- [11. Asymmetric arene hydrogenation: towards sustainability and application - PMC \[pmc.ncbi.nlm.nih.gov\]](#)
- [12. Noyori Hydrogenation | NROChemistry \[nrochemistry.com\]](#)

- [13. semanticscholar.org \[semanticscholar.org\]](https://www.semanticscholar.org)
- [14. Probing machine learning models based on high throughput experimentation data for the discovery of asymmetric hydrogenation catalysts - PMC \[pmc.ncbi.nlm.nih.gov\]](#)
- To cite this document: BenchChem. [Application Notes & Protocols: Asymmetric Hydrogenation for Stereoselective Synthesis]. BenchChem, [2026]. [Online PDF]. Available at: [<https://www.benchchem.com/product/b1610023/docs#application-notes-protocols-asymmetric-hydrogenation-for-stereoselective-synthesis>]

---

### Disclaimer & Data Validity:

The information provided in this document is for Research Use Only (RUO) and is strictly not intended for diagnostic or therapeutic procedures. While BenchChem strives to provide accurate protocols, we make no warranties, express or implied, regarding the fitness of this product for every specific experimental setup.

**Technical Support:** The protocols provided are for reference purposes. Unsure if this reagent suits your experiment?

**Need Industrial/Bulk Grade?** [Request Custom Synthesis Quote](#)

## BenchChem

Our mission is to be the trusted global source of essential and advanced chemicals, empowering scientists and researchers to drive progress in science and industry.

### Contact

Address: 3281 E Guasti Rd  
Ontario, CA 91761, United States  
Phone: (601) 213-4426  
Email: [info@benchchem.com](mailto:info@benchchem.com)

[Contact our Ph.D. Support Team for a compatibility check](#)

