

Preventing degradation of [Correct Compound Name] in solution

Author: BenchChem Technical Support Team. **Date:** May 2026

Compound of Interest

Compound Name: MDL 100151

CAS No.: 139290-69-0

Cat. No.: B161199

[Get Quote](#)

Technical Support Center: Cisplatin Solution Stability

From the desk of the Senior Application Scientist

Welcome to our dedicated resource for researchers, scientists, and drug development professionals working with Cisplatin. This guide provides in-depth answers to common questions and robust troubleshooting strategies to ensure the stability and integrity of your Cisplatin solutions. Preventing degradation is paramount for reproducible and accurate experimental outcomes.

Part 1: Frequently Asked Questions (FAQs) - Understanding Cisplatin Degradation

Q1: What is the primary mechanism of Cisplatin degradation in solution?

A1: The principal degradation pathway for Cisplatin in aqueous solution is a substitution reaction known as aquation or hydrolysis. In this reversible process, the chloride ligands on the Cisplatin molecule are sequentially replaced by water molecules.[1][2][3] This is significant because the resulting aquated species, such as $\text{cis-}[\text{Pt}(\text{NH}_3)_2\text{Cl}(\text{H}_2\text{O})]^+$ (mono-aqua species) and $\text{cis-}[\text{Pt}(\text{NH}_3)_2(\text{H}_2\text{O})_2]^{2+}$ (diaqua species), are highly reactive and are believed to be the active forms that bind to DNA.[1][2] However, for experimental purposes, controlling this process is key to maintaining a solution of known composition. The equilibrium of these species is highly dependent on the chloride ion concentration in the solution.[4][5]

Q2: How does chloride ion concentration affect Cisplatin stability?

A2: Chloride concentration is the most critical factor in preventing Cisplatin degradation. According to Le Chatelier's principle, a high concentration of chloride ions in the solution will suppress the hydrolysis/aquation process, pushing the equilibrium back towards the stable, parent Cisplatin molecule.[1]

- High Chloride (e.g., 0.9% NaCl): In solutions with high chloride content, like normal saline (154 mM NaCl), the degradation of Cisplatin is minimal.[1] Studies have shown that Cisplatin is stable for at least 24 hours, and often much longer, in admixtures containing sodium chloride concentrations of 0.3% or greater.[4][6][7][8]
- Low Chloride (e.g., 5% Dextrose in Water - D5W): In solutions with low or no chloride ions, Cisplatin rapidly undergoes aquation, leading to significant degradation.[9] Therefore, diluting Cisplatin in chloride-free solutions like D5W is strongly discouraged.[7][10]

Q3: What role do pH and temperature play in the stability of Cisplatin solutions?

A3: Both pH and temperature are significant factors influencing the rate of degradation:

- pH: The optimal pH for Cisplatin stability is in the acidic range, typically between 3.5 and 5.5. [11][12] As the pH increases (becomes more alkaline), the rate of degradation can accelerate.[13][14] USP guidelines for constituted Cisplatin for Injection specify a pH range between 3.5 and 6.2.[15]

- **Temperature:** Refrigeration of Cisplatin solutions is generally not recommended. While lower temperatures can slow down chemical reactions, Cisplatin has limited solubility at cold temperatures, which can lead to the formation of a crystalline precipitate.[4][12][16] Storage at controlled room temperature (15–25°C or 68-77°F) is recommended to avoid precipitation.[11][17]

Part 2: Practical Guide to Preparing and Storing Stable Cisplatin Solutions

Q4: What is the recommended solvent for preparing a Cisplatin stock solution?

A4: The universally recommended solvent is a sterile sodium chloride solution, most commonly 0.9% Sodium Chloride Injection, USP (normal saline).[4][6] This provides the necessary chloride ion concentration to ensure stability. Avoid using organic solvents like DMSO for long-term storage, as this has been shown to cause a loss of potency.[18] While Dimethylformamide (DMF) appears to be a more suitable organic solvent than DMSO, aqueous-based saline solutions remain the gold standard for stability.[18]

Q5: How should I handle and store my prepared Cisplatin solutions?

A5: Proper handling and storage are crucial for maintaining the integrity of your Cisplatin solutions.

- **Light Protection:** Cisplatin is sensitive to light, particularly short-wavelength visible light (350–490 nm), which can accelerate degradation.[11][13][14][19] Always protect solutions from light by using amber vials, aluminum foil, or light-blocking bags.[4][13][20] Studies show that solutions stored in amber glass flasks are better protected than those in clear flasks.[13][14]
- **Container and Equipment:** Do not use any equipment containing aluminum parts (e.g., needles, syringes, IV sets) for the preparation or administration of Cisplatin.[7][10][16][17] Aluminum reacts with Cisplatin, causing a black or brown precipitate to form and a significant loss of potency.[12][17] Stainless steel components are acceptable.[12] Cisplatin solutions have shown stability in both glass containers and polyethylene or PVC bags.[11][21]

- **Storage Duration:** When diluted in 0.9% NaCl and protected from light at room temperature, Cisplatin solutions (e.g., at 0.1 mg/mL) can be stable for extended periods, with some studies showing stability for at least 30 days.[11] For reconstituted vials, stability can be up to 28 days if protected from light.[12] However, for experimental consistency, it is best practice to use freshly prepared solutions whenever possible or to adhere to established stability data for your specific concentration and storage conditions.[4]

Summary of Key Stability Factors

Factor	Recommendation	Rationale & References
Solvent/Diluent	Use 0.9% Sodium Chloride solution. Minimum 0.3% NaCl.	High chloride concentration suppresses aquation (hydrolysis).[1][4][6][7]
pH	Maintain pH between 3.5 and 5.5.	Cisplatin degradation accelerates at higher (more alkaline) pH.[11][12][13]
Temperature	Store at controlled room temperature (15-25°C).	Refrigeration can cause precipitation due to limited solubility.[4][12][16]
Light Exposure	Protect from light at all times.	Light, especially in the 350-490 nm range, causes photodegradation.[11][13][19][20]
Equipment	Do NOT use aluminum components.	Aluminum reacts with Cisplatin, causing precipitation and loss of potency.[10][12][17]

Part 3: Troubleshooting Common Issues

Q6: I observed a precipitate in my Cisplatin solution. What caused this and what should I do?

A6: Precipitation in a Cisplatin solution is most commonly caused by one of two things:

- **Storage at Low Temperatures:** If the solution was refrigerated, the precipitate is likely the Cisplatin itself coming out of solution due to its lower solubility at cold temperatures.[4][12]
- **Reaction with Aluminum:** If any part of your preparation or storage equipment (syringes, needles) contained aluminum, the precipitate will be a black or brown platinum precipitate. [12][16]

Troubleshooting Steps:

- **Identify the Cause:** Review your storage conditions and all equipment used. If aluminum was used, the solution is compromised and must be discarded.
- **Address Temperature-Related Precipitate:** If the precipitation is due to cold storage, you may be able to redissolve it by allowing the solution to warm to room temperature. Gentle sonication has also been used to redissolve the precipitate.[12] However, ensure the solution becomes completely clear before use. If it does not fully redissolve, it should be discarded. To prevent recurrence, store solutions at room temperature.

Q7: My experimental results are inconsistent. Could Cisplatin degradation be the cause?

A7: Yes, inconsistent results are a classic sign of solution instability. If the parent Cisplatin is degrading into its more reactive aquated forms, the effective concentration and composition of your solution are changing over time.

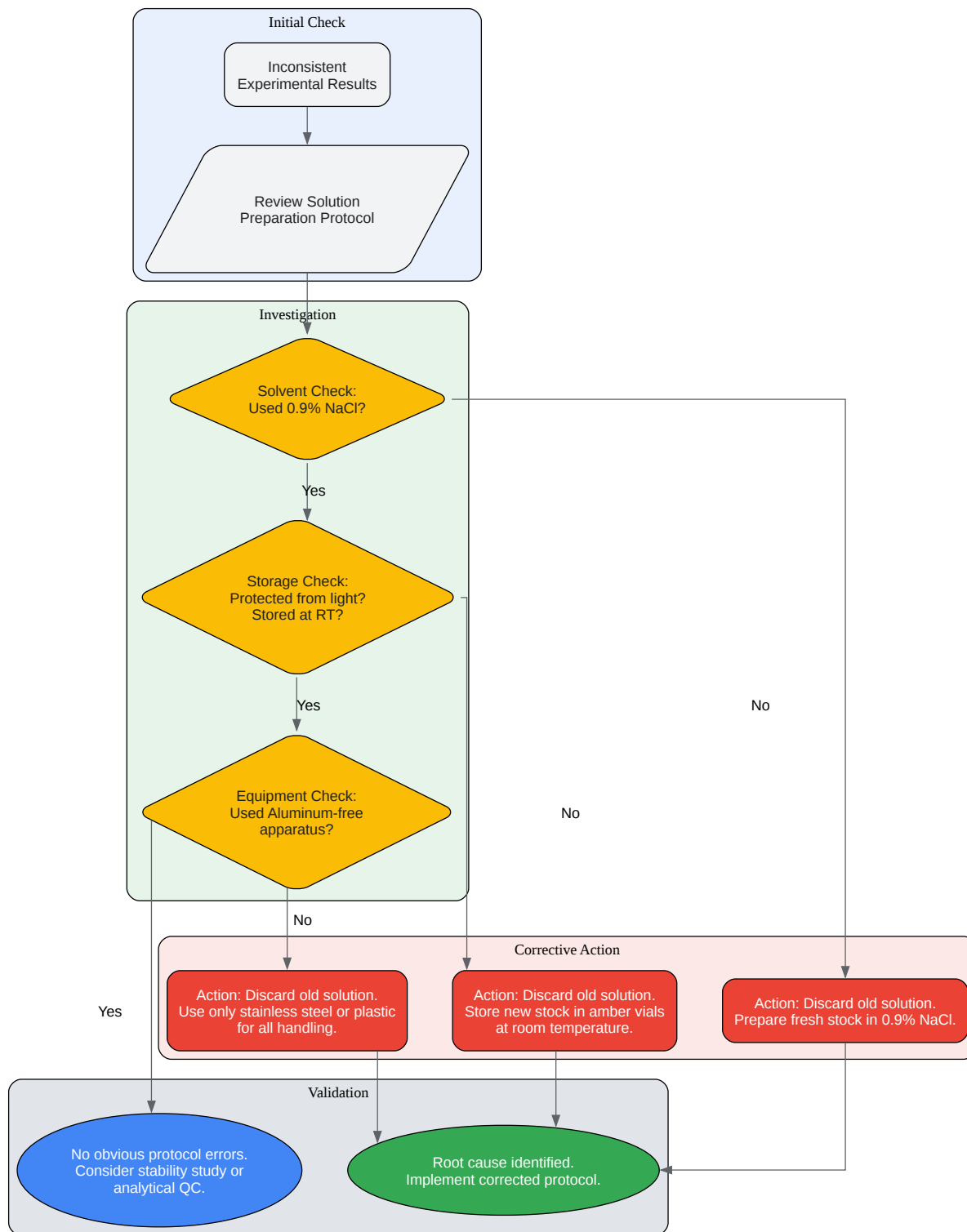

[Click to download full resolution via product page](#)

Caption: Troubleshooting workflow for Cisplatin solution instability.

Part 4: Experimental Protocols

Protocol 1: Preparation of a Stable 1 mg/mL Cisplatin Stock Solution

This protocol describes the preparation of a 10 mL stock solution of Cisplatin at a concentration of 1 mg/mL (approx. 3.3 mM).

Materials:

- Cisplatin powder (handle with extreme care in a designated area, following all safety protocols).[\[22\]](#)[\[23\]](#)[\[24\]](#)[\[25\]](#)
- Sterile 0.9% Sodium Chloride Injection, USP.
- Sterile 15 mL polypropylene conical tube (or a sterile amber glass vial).
- Calibrated analytical balance.
- Stainless steel spatula.
- Vortex mixer.
- Aluminum foil.

Procedure:

- **Safety First:** Don appropriate Personal Protective Equipment (PPE), including double gloves, a lab coat, and safety glasses. All handling of solid Cisplatin must be performed in a certified chemical fume hood or biological safety cabinet.[\[23\]](#)[\[24\]](#)[\[25\]](#)
- **Weighing:** Tare a sterile 15 mL conical tube on the analytical balance. Carefully weigh 10.0 mg of Cisplatin powder directly into the tube.
- **Reconstitution:** Using a sterile pipette, add exactly 10.0 mL of 0.9% Sodium Chloride Injection to the tube containing the Cisplatin powder.

- **Dissolution:** Cap the tube securely. Vortex the solution for 2-3 minutes or until all the powder is completely dissolved. The resulting solution should be clear and pale yellow.[26]
- **Light Protection:** Immediately wrap the tube completely with aluminum foil to protect it from light.
- **Labeling:** Label the tube clearly with "Cisplatin Stock Solution, 1 mg/mL in 0.9% NaCl," the preparation date, and your initials.
- **Storage:** Store the wrapped tube at controlled room temperature (15-25°C). Do not refrigerate.

Protocol 2: Quality Control Check via UV-Vis Spectroscopy

A simple QC check can be performed to monitor for gross degradation. Degradation of Cisplatin to its aquated forms results in changes to its UV absorption spectrum.[4] This is not a replacement for HPLC, but can detect significant changes.

Procedure:

- Prepare a fresh dilution of your Cisplatin stock solution in 0.9% NaCl to a final concentration suitable for your spectrophotometer (e.g., 10-20 µg/mL).
- Scan the absorbance from 250 nm to 350 nm.
- Intact Cisplatin in a chloride medium has a characteristic absorption maximum around 300-301 nm.[4][19]
- Record this initial spectrum as your baseline "Time 0" reference.
- Periodically re-run the spectrum on the same solution (or a newly prepared dilution from the same stock) under the same conditions. A significant decrease in the peak at 301 nm or a shift in the spectral shape may indicate degradation.

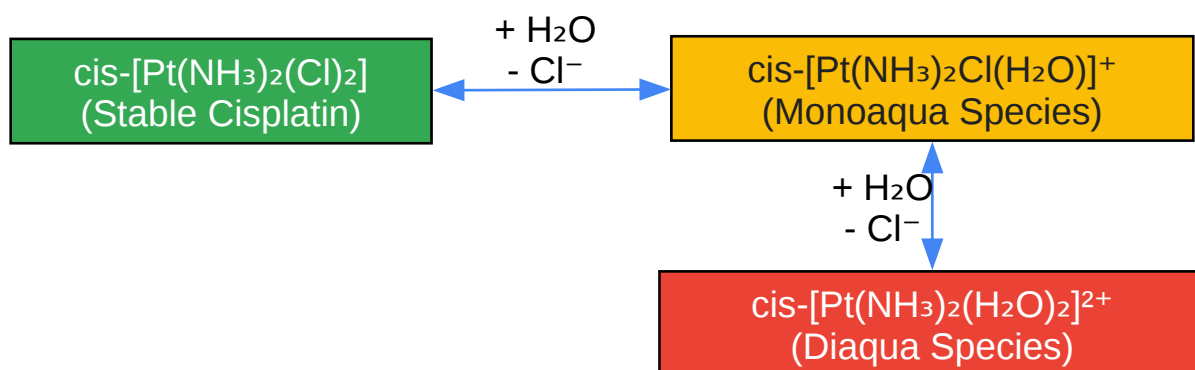

[Click to download full resolution via product page](#)

Caption: Reversible aquation (hydrolysis) of Cisplatin.

References

- The physical and chemical stability of cisplatin (Teva) in concentrate and diluted in sodium chloride 0.9%. PubMed Central. Available at: [\[Link\]](#)
- Stability of cisplatin in aqueous solution. American Journal of Health-System Pharmacy. Available at: [\[Link\]](#)
- Stability of cisplatin, iproplatin, carboplatin, and tetraplatin in commonly used intravenous solutions. PubMed. Available at: [\[Link\]](#)
- Characterization of cisplatin degradation as affected by pH and light. PubMed. Available at: [\[Link\]](#)
- Cisplatin and Beyond: Molecular Mechanisms of Action and Drug Resistance Development in Cancer Chemotherapy. National Institutes of Health (NIH). Available at: [\[Link\]](#)
- Physicochemical stability of Cisplatin Accord in punctured original vials, syringes and after dilution with 0.9% sodium chloride solution. GaBI Journal. Available at: [\[Link\]](#)
- Cisplatin. ASHP Publications. Available at: [\[Link\]](#)
- HIGHLIGHTS OF PRESCRIBING INFORMATION These highlights do not include all the information needed to use CISPLATIN INJECTION safely. accessdata.fda.gov. Available at:

[\[Link\]](#)

- Cisplatin for Injection, USP. WG Critical Care. Available at: [\[Link\]](#)
- CISplatin. CHEO ED Outreach. Available at: [\[Link\]](#)
- Decomposition of cisplatin in aqueous solutions containing chlorides by ultrasonic energy and light. PubMed. Available at: [\[Link\]](#)
- USP Monographs: Cisplatin for Injection. USP-NF. Available at: [\[Link\]](#)
- Cisplatin-Platinol-AQ®. GlobalRPH. Available at: [\[Link\]](#)
- Characterization of cisplatin degradation as affected by pH and light. Semantic Scholar. Available at: [\[Link\]](#)
- A Study of Method Development, Validation and Forced Degradation for Simultaneous Quantification of Cisplatin and Fluorouracil. PharmaInfo. Available at: [\[Link\]](#)
- Stability of cisplatin, iproplatin, carboplatin, and tetraplatin in commonly used intravenous solutions. Semantic Scholar. Available at: [\[Link\]](#)
- Pr Cisplatin Injection - PRODUCT MONOGRAPH. Hospira. Available at: [\[Link\]](#)
- Kinetics of Cisplatin and its monohydrated complex with sulfur-containing compounds designed for local otoprotective administration. PubMed. Available at: [\[Link\]](#)
- Effects of Solvents on In Vitro Potencies of Platinum Compounds. National Institutes of Health (NIH). Available at: [\[Link\]](#)
- Cisplatin 1 mg/ml Concentrate for Solution for Infusion. medicines.org.uk. Available at: [\[Link\]](#)
- Analytical Methods for the Quantification of Cisplatin, Carboplatin, and Oxaliplatin in Various Matrices over the Last Two Decades. ResearchGate. Available at: [\[Link\]](#)
- Stability and compatibility of cisplatin and carboplatin with PVC infusion bags. PubMed. Available at: [\[Link\]](#)

- new zealand data sheet cisplatin accord (cisplatin) solution for injection 1 product name. Medsafe. Available at: [\[Link\]](#)
- Influence of chemical structure and mechanism of hydrolysis on pharmacological activity and toxicological profile of approved platinum drugs. Pharmacia. Available at: [\[Link\]](#)
- Effect of different shielding conditions on the stability of Cisplatin. National Institutes of Health (NIH). Available at: [\[Link\]](#)
- Cisplatin-Membrane Interactions and Their Influence on Platinum Complexes Activity and Toxicity. Frontiers. Available at: [\[Link\]](#)
- Quantitative determination of cisplatin in plasma and urine in clinical research by triple quadrupole LC/MS/MS. Agilent. Available at: [\[Link\]](#)
- Cisplatin equilibrium in aqueous medium where it exchanges chloride... ResearchGate. Available at: [\[Link\]](#)
- Analytical methodologies for the determination of cisplatin. PubMed. Available at: [\[Link\]](#)
- Handling Hazardous Meds. Hospital Pharmacy Technician's Letter. Available at: [\[Link\]](#)
- The hydrolysis products of cis-diamminedichloroplatinum(II) 5. The anation kinetics of cis-Pt(X)(NH₃)₂(OH)₂⁺ (XCl, OH) with glycine, monohydrogen malonate and chloride. Semantic Scholar. Available at: [\[Link\]](#)
- SOP FOR Cisplatin. Amherst College. Available at: [\[Link\]](#)
- Hydrolysis of the Anticancer Drug Cisplatin: Pitfalls in the Interpretation of Quantum Chemical Calculations. Semantic Scholar. Available at: [\[Link\]](#)

Need Custom Synthesis?

BenchChem offers custom synthesis for rare earth carbides and specific isotopic labeling.

Email: info@benchchem.com or [Request Quote Online](#).

Sources

- [1. Cisplatin and Beyond: Molecular Mechanisms of Action and Drug Resistance Development in Cancer Chemotherapy - PMC \[pmc.ncbi.nlm.nih.gov\]](#)
- [2. Influence of chemical structure and mechanism of hydrolysis on pharmacological activity and toxicological profile of approved platinum drugs \[pharmacia.pensoft.net\]](#)
- [3. researchgate.net \[researchgate.net\]](#)
- [4. academic.oup.com \[academic.oup.com\]](#)
- [5. Frontiers | Cisplatin-Membrane Interactions and Their Influence on Platinum Complexes Activity and Toxicity \[frontiersin.org\]](#)
- [6. Stability of cisplatin, iproplatin, carboplatin, and tetraplatin in commonly used intravenous solutions - PubMed \[pubmed.ncbi.nlm.nih.gov\]](#)
- [7. CISplatin | CHEO ED Outreach \[outreach.cheo.on.ca\]](#)
- [8. Stability of cisplatin, iproplatin, carboplatin, and tetraplatin in commonly used intravenous solutions. | Semantic Scholar \[semanticscholar.org\]](#)
- [9. Physicochemical stability of Cisplatin Accord in punctured original vials, syringes and after dilution with 0.9% sodium chloride solution - GaBIJ \[gabi-journal.net\]](#)
- [10. globalrph.com \[globalrph.com\]](#)
- [11. The physical and chemical stability of cisplatin \(Teva\) in concentrate and diluted in sodium chloride 0.9% - PMC \[pmc.ncbi.nlm.nih.gov\]](#)
- [12. publications.ashp.org \[publications.ashp.org\]](#)
- [13. Characterization of cisplatin degradation as affected by pH and light - PubMed \[pubmed.ncbi.nlm.nih.gov\]](#)
- [14. Characterization of cisplatin degradation as affected by pH and light. | Semantic Scholar \[semanticscholar.org\]](#)
- [15. pharmacopeia.cn \[pharmacopeia.cn\]](#)
- [16. pdf.hres.ca \[pdf.hres.ca\]](#)
- [17. accessdata.fda.gov \[accessdata.fda.gov\]](#)
- [18. Effects of Solvents on In Vitro Potencies of Platinum Compounds - PMC \[pmc.ncbi.nlm.nih.gov\]](#)
- [19. Decomposition of cisplatin in aqueous solutions containing chlorides by ultrasonic energy and light - PubMed \[pubmed.ncbi.nlm.nih.gov\]](#)

- 20. Effect of different shielding conditions on the stability of Cisplatin - PMC [pmc.ncbi.nlm.nih.gov]
- 21. Stability and compatibility of cisplatin and carboplatin with PVC infusion bags - PubMed [pubmed.ncbi.nlm.nih.gov]
- 22. wgcriticalcare.com [wgcriticalcare.com]
- 23. hospital-pharmacytech.therapeuticresearch.com [hospital-pharmacytech.therapeuticresearch.com]
- 24. uspnf.com [uspnf.com]
- 25. amherst.edu [amherst.edu]
- 26. medsafe.govt.nz [medsafe.govt.nz]
- To cite this document: BenchChem. [Preventing degradation of [Correct Compound Name] in solution]. BenchChem, [2026]. [Online PDF]. Available at: [<https://www.benchchem.com/product/b161199/docs#preventing-degradation-of-correct-compound-name-in-solution>]

Disclaimer & Data Validity:

The information provided in this document is for Research Use Only (RUO) and is strictly not intended for diagnostic or therapeutic procedures. While BenchChem strives to provide accurate protocols, we make no warranties, express or implied, regarding the fitness of this product for every specific experimental setup.

Technical Support: The protocols provided are for reference purposes. Unsure if this reagent suits your experiment?

Need Industrial/Bulk Grade? [Request Custom Synthesis Quote](#)

BenchChem

Our mission is to be the trusted global source of essential and advanced chemicals, empowering scientists and researchers to drive progress in science and industry.

Contact

Address: 3281 E Guasti Rd
Ontario, CA 91761, United States
Phone: (601) 213-4426
Email: info@benchchem.com

Contact our Ph.D. Support Team for a compatibility check