

Application Note & Protocol: N-Boc Protection of 2,3-Diphenylmorpholin-6-one

Author: BenchChem Technical Support Team. **Date:** May 2026

Compound of Interest

Compound Name: *tert-Butyl 6-oxo-2,3-diphenyl-4-morpholinecarboxylate*

CAS No.: 302911-78-0

Cat. No.: B1609116

[Get Quote](#)

For: Researchers, Scientists, and Drug Development Professionals

Abstract

The tert-butyloxycarbonyl (Boc) protecting group is a cornerstone in modern organic synthesis, particularly in the fields of medicinal chemistry and drug development.^{[1][2][3]} Its widespread use is attributed to the ease of its introduction, its stability under a variety of reaction conditions, and the mild acidic conditions required for its removal.^{[1][2]} This document provides a comprehensive guide to the N-Boc protection of 2,3-diphenylmorpholin-6-one, a heterocyclic scaffold of potential interest in pharmaceutical research. This protocol details the underlying reaction mechanism, a step-by-step experimental procedure, and the rationale behind the choice of reagents and conditions, ensuring a robust and reproducible method for researchers.

Introduction: The Significance of N-Boc Protection

In multi-step organic synthesis, the selective protection of reactive functional groups is a critical strategy.^[1] Amines, being nucleophilic and basic, often require protection to prevent unwanted side reactions during transformations elsewhere in a molecule.^[4] The Boc group, by converting

the amine into a carbamate, effectively masks its reactivity.[2] This protection is stable to many reagents and conditions, yet can be cleanly removed when desired, making it an invaluable tool in the synthesis of complex molecules.[1][5] For a molecule such as 2,3-diphenylmorpholin-6-one, which contains a secondary amine within a morpholinone ring, N-Boc protection would be a crucial step prior to further functionalization, for instance, at the lactone moiety or the phenyl rings.

Reaction Mechanism and Rationale

The N-Boc protection of an amine with di-tert-butyl dicarbonate ((Boc)₂O) proceeds via a nucleophilic acyl substitution mechanism.[2][6] The reaction can be catalyzed by a base, which serves to deprotonate the amine, thereby increasing its nucleophilicity.

Mechanism of N-Boc Protection:

- **Nucleophilic Attack:** The lone pair of electrons on the nitrogen atom of the secondary amine in 2,3-diphenylmorpholin-6-one attacks one of the electrophilic carbonyl carbons of the (Boc)₂O.[1][2][7] This forms a tetrahedral intermediate.
- **Intermediate Collapse:** The tetrahedral intermediate collapses, leading to the elimination of a tert-butyl carbonate leaving group.[2][7]
- **Deprotonation and Byproduct Formation:** A base, such as triethylamine (TEA), deprotonates the now positively charged nitrogen atom.[8] The tert-butyl carbonate subsequently decomposes into the stable and volatile byproducts, carbon dioxide and tert-butanol.[7]

The use of a catalytic amount of 4-(dimethylamino)pyridine (DMAP) can significantly accelerate the reaction.[9][10] DMAP is a hypernucleophilic acylation catalyst that reacts with (Boc)₂O to form a more reactive N-Boc-pyridinium intermediate, which is then readily attacked by the amine.[8][10]

Visualizing the Reaction Pathway

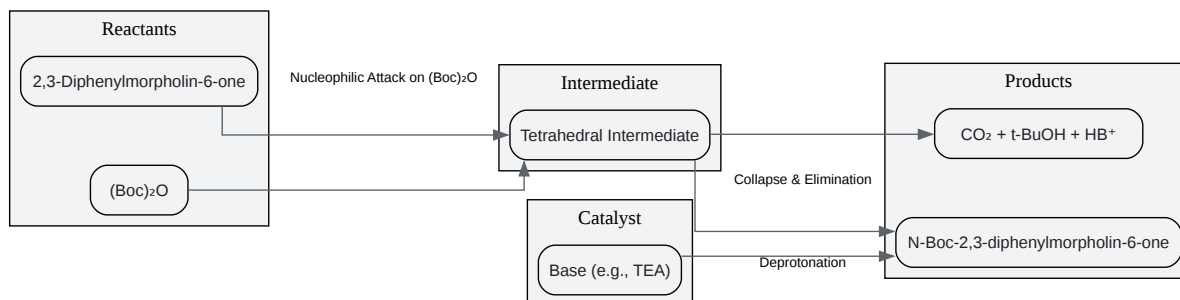

[Click to download full resolution via product page](#)

Caption: Mechanism of N-Boc protection of a secondary amine.

Experimental Protocol

This protocol provides a detailed procedure for the N-Boc protection of 2,3-diphenylmorpholin-6-one.

Materials and Reagents

Reagent/Material	Grade	Supplier Example
2,3-Diphenylmorpholin-6-one	≥95%	N/A
Di-tert-butyl dicarbonate ($(\text{Boc})_2\text{O}$)	Reagent grade, ≥97%	Sigma-Aldrich
Triethylamine (TEA)	≥99.5%, anhydrous	Sigma-Aldrich
4-(Dimethylamino)pyridine (DMAP)	≥99%	Sigma-Aldrich
Dichloromethane (DCM)	Anhydrous, ≥99.8%	Sigma-Aldrich
Saturated aqueous sodium bicarbonate (NaHCO_3)	ACS reagent	Fisher Scientific
Brine (Saturated aqueous NaCl)	ACS reagent	Fisher Scientific
Anhydrous magnesium sulfate (MgSO_4)	≥97%	Sigma-Aldrich
Ethyl acetate	ACS reagent	Fisher Scientific
Hexanes	ACS reagent	Fisher Scientific
Thin-layer chromatography (TLC) plates	Silica gel 60 F ₂₅₄	MilliporeSigma

Equipment

- Round-bottom flask with a magnetic stir bar
- Magnetic stirrer hotplate
- Inert atmosphere setup (e.g., nitrogen or argon balloon)
- Syringes and needles
- Separatory funnel

- Rotary evaporator
- Flash chromatography system

Step-by-Step Procedure

- **Reaction Setup:** To a dry round-bottom flask under an inert atmosphere, add 2,3-diphenylmorpholin-6-one (1.0 eq). Dissolve the starting material in anhydrous dichloromethane (DCM) to a concentration of approximately 0.1 M.
- **Addition of Reagents:** To the stirred solution, add triethylamine (TEA, 1.5 eq) followed by a catalytic amount of 4-(dimethylamino)pyridine (DMAP, 0.1 eq).
- **Addition of (Boc)₂O:** Slowly add a solution of di-tert-butyl dicarbonate ((Boc)₂O, 1.2 eq) in a small amount of anhydrous DCM to the reaction mixture at room temperature. The slow addition is crucial to control the exotherm and gas evolution.^{[8][10]}
- **Reaction Monitoring:** Stir the reaction mixture at room temperature. Monitor the progress of the reaction by thin-layer chromatography (TLC) using a suitable eluent system (e.g., 30% ethyl acetate in hexanes). The reaction is typically complete within 2-4 hours.^[2]
- **Work-up:** Upon completion, dilute the reaction mixture with DCM. Transfer the mixture to a separatory funnel and wash sequentially with saturated aqueous sodium bicarbonate (NaHCO₃) solution, water, and brine.^[2] The aqueous washes help to remove unreacted (Boc)₂O, TEA, and DMAP.
- **Drying and Concentration:** Dry the organic layer over anhydrous magnesium sulfate (MgSO₄), filter, and concentrate the filtrate under reduced pressure using a rotary evaporator.^[2]
- **Purification:** Purify the crude product by flash column chromatography on silica gel using a gradient of ethyl acetate in hexanes to afford the pure N-Boc-2,3-diphenylmorpholin-6-one.

Visualizing the Experimental Workflow

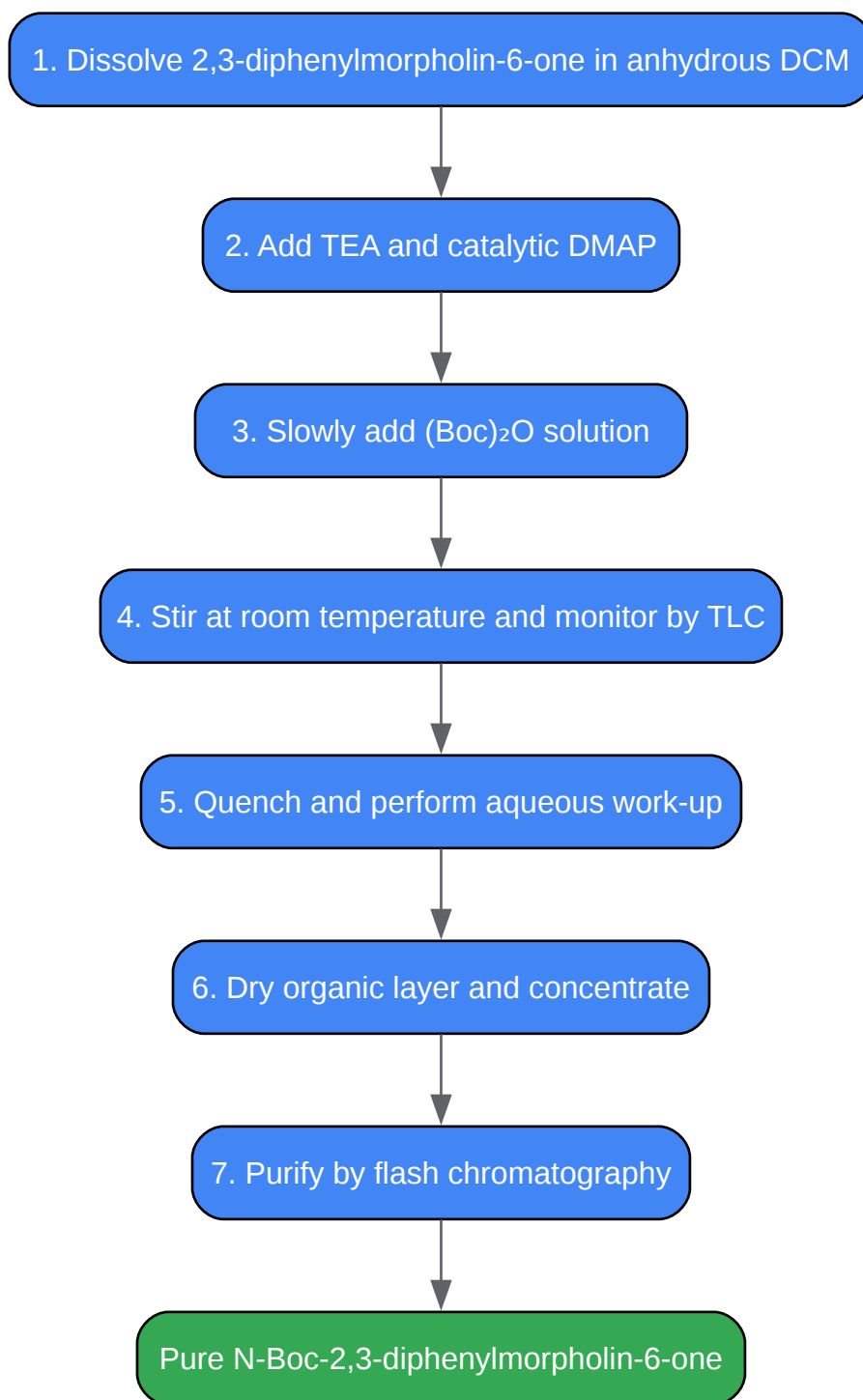

[Click to download full resolution via product page](#)

Caption: Step-by-step workflow for N-Boc protection.

Troubleshooting and Key Considerations

- **Incomplete Reaction:** If the reaction stalls, gentle heating (e.g., to 40 °C) can be applied.[3] Ensure all reagents are of high purity and the solvent is anhydrous.
- **Side Reactions:** The use of excess (Boc)₂O or a large excess of base can sometimes lead to side products.[11] Adhering to the recommended stoichiometry is important.
- **Purification:** The polarity of the N-Boc protected product will be significantly different from the starting amine. This change should be considered when developing a TLC and column chromatography solvent system.
- **Safety:** (Boc)₂O is a skin sensitizer and should be handled with appropriate personal protective equipment. The reaction produces carbon dioxide gas, so it should not be performed in a sealed vessel.[7]

Characterization of the Product

The successful synthesis of N-Boc-2,3-diphenylmorpholin-6-one can be confirmed by standard analytical techniques:

- **¹H and ¹³C NMR Spectroscopy:** To confirm the structure and purity of the product. The appearance of a large singlet in the ¹H NMR spectrum around 1.5 ppm is characteristic of the nine protons of the tert-butyl group.
- **Mass Spectrometry (MS):** To confirm the molecular weight of the protected compound.
- **Infrared (IR) Spectroscopy:** The appearance of a strong carbonyl stretch from the carbamate group (typically around 1700-1720 cm⁻¹) will be indicative of a successful reaction.

Conclusion

This application note provides a robust and well-rationalized protocol for the N-Boc protection of 2,3-diphenylmorpholin-6-one. By understanding the underlying mechanism and adhering to the detailed experimental procedure, researchers can reliably synthesize the protected intermediate, paving the way for further synthetic elaborations in their drug discovery and development programs.

References

- J&K Scientific LLC. (2025, February 8). Boc Protection and Deprotection.
- Common Organic Chemistry. Boc Protection Mechanism (Boc2O).
- Wikipedia. (n.d.). tert-Butyloxycarbonyl protecting group.
- Common Organic Chemistry. Boc Protection Mechanism (Boc2O + DMAP).
- Common Organic Chemistry. Boc Protection Mechanism (Boc2O + Base + DMAP).
- Benchchem. (n.d.). An In-depth Technical Guide to the Boc Protection Mechanism for Amines.
- Sigma-Aldrich. (n.d.). Application Note – N-Boc protection.
- Chemtips - WordPress.com. (2012, June 18). Reactions that Work: Boc Protection.
- Hebei Boze Chemical Co., Ltd. (2023, March 14). Boc Protected Compounds.
- Organic Chemistry Portal. (n.d.). Boc-Protected Amino Groups.
- Fisher Scientific. (n.d.). Amine Protection / Deprotection.
- ACS Publications. (n.d.). Di-tert-butyl Dicarboxylate and 4-(Dimethylamino)pyridine Revisited. Their Reactions with Amines and Alcohols¹. The Journal of Organic Chemistry.
- NIH. (n.d.). A One-Pot Selective Synthesis of N-Boc Protected Secondary Amines.
- ResearchGate. (2025, August 10). (PDF) Di-tert-butyl Dicarboxylate and 4-(Dimethylamino)pyridine Revisited. Their Reactions with Amines and Alcohols¹.
- Scribd. (n.d.). Application Note - N-Boc Protection | PDF | Amine | Organic Chemistry.
- Benchchem. (n.d.). comparing the efficacy of different bases in N-Boc protection reactions.
- Chemistry Steps. (n.d.). Boc Protecting Group for Amines.

Need Custom Synthesis?

BenchChem offers custom synthesis for rare earth carbides and specific isotopic labeling.

Email: info@benchchem.com or [Request Quote Online](#).

Sources

- 1. nbinno.com [nbinno.com]
- 2. pdf.benchchem.com [pdf.benchchem.com]
- 3. [Amine Protection / Deprotection](http://fishersci.co.uk) [fishersci.co.uk]
- 4. [One moment, please...](http://chemistrysteps.com) [chemistrysteps.com]
- 5. [Boc-Protected Amino Groups](http://organic-chemistry.org) [organic-chemistry.org]
- 6. jk-sci.com [jk-sci.com]
- 7. [Boc Protection Mechanism \(Boc2O\)](http://commonorganicchemistry.com) [commonorganicchemistry.com]

- [8. Boc Protection Mechanism \(Boc2O + Base + DMAP\) \[commonorganicchemistry.com\]](#)
- [9. tert-Butyloxycarbonyl protecting group - Wikipedia \[en.wikipedia.org\]](#)
- [10. Boc Protection Mechanism \(Boc2O + DMAP\) \[commonorganicchemistry.com\]](#)
- [11. Boc Protected Compounds \[bzchemicals.com\]](#)
- To cite this document: BenchChem. [Application Note & Protocol: N-Boc Protection of 2,3-Diphenylmorpholin-6-one]. BenchChem, [2026]. [Online PDF]. Available at: [<https://www.benchchem.com/product/b1609116/docs#application-note-protocol-n-boc-protection-of-2-3-diphenylmorpholin-6-one>]

Disclaimer & Data Validity:

The information provided in this document is for Research Use Only (RUO) and is strictly not intended for diagnostic or therapeutic procedures. While BenchChem strives to provide accurate protocols, we make no warranties, express or implied, regarding the fitness of this product for every specific experimental setup.

Technical Support: The protocols provided are for reference purposes. Unsure if this reagent suits your experiment?

Need Industrial/Bulk Grade? [Request Custom Synthesis Quote](#)

BenchChem

Our mission is to be the trusted global source of essential and advanced chemicals, empowering scientists and researchers to drive progress in science and industry.

Contact

Address: 3281 E Guasti Rd
Ontario, CA 91761, United States
Phone: (601) 213-4426
Email: info@benchchem.com

[Contact our Ph.D. Support Team for a compatibility check](#)

