

Technical Support Center: Pilot-Scale Synthesis of *o*-(2-Naphthyl)phenol

Author: BenchChem Technical Support Team. **Date:** May 2026

Compound of Interest

Compound Name: *o*-(2-Naphthyl)phenol

CAS No.: 78210-35-2

Cat. No.: B1608689

[Get Quote](#)

Prepared by: Your Senior Application Scientist

This guide provides in-depth technical support for researchers, scientists, and drug development professionals scaling up the synthesis of ***o*-(2-Naphthyl)phenol**. We will focus on the robust and widely applicable Suzuki-Miyaura cross-coupling reaction, addressing potential challenges and frequently asked questions to ensure a successful transition from bench-scale to pilot studies.

Frequently Asked Questions (FAQs)

Q1: Why is the Suzuki-Miyaura coupling the recommended method for scaling up ***o*-(2-Naphthyl)phenol** synthesis?

The Suzuki-Miyaura coupling is a palladium-catalyzed reaction that forms a carbon-carbon bond between an organoboron compound and an organohalide.^{[1][2]} For the synthesis of ***o*-(2-Naphthyl)phenol**, this typically involves coupling 2-naphthylboronic acid with 2-bromophenol or 2-iodophenol. This method is favored for scale-up due to several key advantages:

- **High Functional Group Tolerance:** The reaction conditions are generally mild and compatible with a wide range of functional groups, including the phenol's hydroxyl group, minimizing the need for protecting group strategies.[1]
- **Commercial Availability of Reagents:** The starting materials, such as 2-naphthylboronic acid and 2-halophenols, are commercially available, simplifying the supply chain for larger-scale production.
- **Favorable Safety and Toxicity Profile:** The boronic acid reagents are significantly less toxic and more stable than other organometallic compounds used in similar cross-coupling reactions, like organotin (Stille coupling) or organozinc (Negishi coupling).[1][3]
- **"Greener" Chemistry:** The reaction byproducts are typically inorganic salts and water-soluble boron compounds, which are easier to remove and dispose of compared to the toxic byproducts of other methods.[1]

Q2: What are the primary safety concerns when scaling up this reaction?

Scaling up any chemical process introduces new safety considerations. For the Suzuki-Miyaura coupling, the primary hazards are:

- **Exothermic Reactions:** Palladium-catalyzed cross-coupling reactions are exothermic.[4] On a large scale, the heat generated can accumulate rapidly if not managed properly, potentially leading to a runaway reaction. It is crucial to understand the thermal profile of the reaction through calorimetric studies (e.g., DSC or ARC) before proceeding to pilot scale.[4][5]
- **Flammable Solvents:** Solvents commonly used in Suzuki couplings, such as tetrahydrofuran (THF), dioxane, and toluene, are flammable.[6] Large volumes increase the risk of fire or explosion. Ensure all equipment is properly grounded and operated in a well-ventilated area with appropriate fire suppression systems.
- **Peroxide Formation:** Etheral solvents like THF and dioxane can form explosive peroxides upon exposure to air.[7] Always use freshly distilled or inhibitor-free solvents from a sealed source, and test for peroxides before use.[7]

- **Catalyst Handling:** Palladium catalysts, especially when finely divided, can be pyrophoric. Handle them under an inert atmosphere (e.g., nitrogen or argon).

Q3: How critical is solvent and reagent purity for a successful scale-up?

Extremely critical. While small-scale reactions might tolerate minor impurities, these can have a dramatic negative impact on a pilot-scale run.

- **Solvent Degassing:** Oxygen can oxidize the active Pd(0) catalyst and phosphine ligands, leading to catalyst deactivation and low yields.^[7] It is imperative to thoroughly degas all solvents before use. Common methods include sparging with an inert gas (argon or nitrogen) or freeze-pump-thaw cycles.^[7]
- **Water Content:** While some Suzuki reactions benefit from the presence of water (often to dissolve the inorganic base), the amount must be controlled.^[7] Using anhydrous solvents and then adding a specific, measured amount of water for the base solution provides the best reproducibility.
- **Reagent Quality:** Ensure the purity of your boronic acid and aryl halide. Impurities can interfere with the catalytic cycle and lead to difficult-to-remove side products.

Troubleshooting Guide

Q1: My reaction has stalled; LCMS analysis shows significant amounts of starting material remaining after several hours. What went wrong?

This is a common issue often related to catalyst deactivation.

- **Cause - Catalyst Deactivation:** The active Pd(0) catalyst may have been oxidized or precipitated as "palladium black." This can happen if the initial degassing was insufficient or if there is an air leak in your reactor.^[7]
- **Solution:**
 - **Check for Leaks:** Ensure all seals and joints on your reactor are secure.

- Add Additional Ligand: Sometimes, adding a small amount of extra phosphine ligand can help stabilize the catalyst and prevent precipitation.[7]
- Add More Catalyst: If the reaction has completely stopped, carefully add a fresh portion of the catalyst under a positive pressure of inert gas. However, this may complicate purification. The better long-term solution is to optimize the initial reaction conditions.[7]
- Cause - Poor Base Solubility: The inorganic base (e.g., K_2CO_3 , K_3PO_4) must be at least partially dissolved to participate in the reaction.[3][7]
- Solution: Ensure you are using a 2M aqueous solution for the base as specified in the protocol, rather than adding it as a solid.[7] Vigorous stirring is essential to ensure good mixing between the organic and aqueous phases.

Q2: The yield is low, and I've isolated a significant amount of phenol (from the 2-halophenol) and naphthalene (from the boronic acid). What is causing this?

This points to a side reaction called protodeboronation, where the boronic acid is cleaved by a proton source before it can couple with the aryl halide.

- Cause - Boronic Acid Instability: Boronic acids can be unstable, especially at elevated temperatures or in the presence of excess water or acid/base.[6][8]
- Solutions:
 - Control Temperature: Do not exceed the recommended reaction temperature. Overheating can accelerate the decomposition of the boronic acid.
 - Use a Milder Base: If protodeboronation is severe, consider switching to a milder base like potassium fluoride (KF).[8]
 - Use a Boronic Ester: Boronic esters, such as pinacol esters, are often more stable than the corresponding boronic acids and can be used to suppress this side reaction.[6]

- **Minimize Reaction Time:** Monitor the reaction closely and begin workup as soon as the starting material is consumed to minimize the time the boronic acid is exposed to harsh conditions.

Q3: My final product is dark and difficult to purify. How can I remove residual palladium?

Palladium contamination is a critical issue, especially in pharmaceutical applications. The black or dark color is often due to residual palladium black.

- **Solution - Post-Reaction Scavenging:**
 - **Activated Carbon Treatment:** After the reaction is complete, the mixture can be filtered through a pad of Celite® to remove the bulk of the precipitated palladium. The resulting solution can then be treated with activated carbon (charcoal) and stirred for several hours before another filtration.
 - **Thiol-Based Scavengers:** For more effective removal, use silica-based scavengers functionalized with thiol groups (e.g., SiliaMetS® Thiol). These have a high affinity for palladium and can be easily removed by filtration.
 - **Aqueous Washes:** Washing the organic layer with an aqueous solution of a chelating agent like thiourea or sodium thioglycolate can also help extract residual palladium.

Q4: The workup is forming a persistent emulsion. How can I break it?

Emulsions are common during the aqueous workup of large-scale reactions, especially with biphasic mixtures.

- **Solutions:**
 - **Add Brine:** Add a saturated aqueous solution of sodium chloride (brine). This increases the ionic strength of the aqueous phase, which often helps to break the emulsion.
 - **Change Solvent:** If possible, adding a small amount of a different organic solvent can alter the phase properties and break the emulsion.

- Filtration: Filtering the entire emulsified mixture through a pad of a filter aid like Celite® can sometimes resolve the issue.
- Patience: Sometimes, simply letting the mixture stand for an extended period in a separatory funnel will allow the layers to separate.

Pilot-Scale Experimental Protocol

This protocol is designed for a 20 L jacketed glass reactor. All operations should be conducted under a nitrogen atmosphere.

Reaction Scheme: Suzuki-Miyaura Coupling

(A) 2-Naphthylboronic Acid + (B) 2-Bromophenol → (C) **o-(2-Naphthyl)phenol**

Step 1: Reagent Preparation & Reactor Setup

- Ensure the 20 L reactor is clean, dry, and has been purged with nitrogen.
- Charge the reactor with 2-Naphthylboronic Acid (1.00 kg, 5.81 mol, 1.0 eq) and 2-Bromophenol (1.11 kg, 6.40 mol, 1.1 eq).
- Add Toluene (8 L) to the reactor. Begin stirring to dissolve the solids.
- In a separate vessel, prepare the base solution by dissolving Potassium Carbonate (K_2CO_3) (2.41 kg, 17.4 mol, 3.0 eq) in Deionized Water (8 L). Degas this solution by bubbling nitrogen through it for at least 30 minutes.

Step 2: Reaction Execution

- Add the degassed K_2CO_3 solution to the reactor.
- Begin vigorous stirring to create a well-mixed biphasic system.
- Sparge the reactor headspace and the liquid phase with nitrogen for 45 minutes to ensure the removal of dissolved oxygen.
- Under a strong positive pressure of nitrogen, add the palladium catalyst, [1,1'-Bis(diphenylphosphino)ferrocene]dichloropalladium(II) complex with dichloromethane

(Pd(dppf)Cl₂·CH₂Cl₂) (47.5 g, 0.058 mol, 0.01 eq).

- Heat the reactor jacket to 90-95 °C to bring the internal reaction temperature to a gentle reflux (~85 °C).
- Maintain the reaction at this temperature for 4-6 hours. Monitor the reaction progress by taking small aliquots for LCMS or TLC analysis.

Step 3: Workup and Isolation

- Once the reaction is complete (consumption of the limiting reagent), cool the reactor to room temperature (20-25 °C).
- Transfer the reaction mixture to a larger separatory vessel. Allow the layers to separate and remove the lower aqueous layer.
- Wash the organic layer sequentially with:
 - 2 M Hydrochloric Acid (HCl) (5 L) to neutralize any remaining base and protonate the phenolate.
 - Deionized Water (5 L).
 - Saturated Brine (5 L) to help break any emulsions and remove water.
- Dry the organic layer over anhydrous sodium sulfate (Na₂SO₄), then filter.
- Concentrate the organic layer under reduced pressure using a rotary evaporator to obtain the crude product as a dark oil or solid.

Step 4: Purification

- Dissolve the crude product in a minimal amount of hot toluene.
- Add activated carbon (charcoal, ~50 g) and stir for 1 hour at 60 °C to scavenge residual palladium.
- Filter the hot solution through a pad of Celite® to remove the carbon.

- Allow the filtrate to cool slowly to room temperature, then cool further to 0-5 °C to induce crystallization.
- Collect the crystalline product by filtration, wash with a small amount of cold hexanes, and dry under vacuum to a constant weight.

Data Presentation

Parameter	Target Value	Notes
Scale	1.00 kg (2-Naphthylboronic Acid)	Limiting Reagent
Equivalents	1.1 eq 2-Bromophenol, 3.0 eq K ₂ CO ₃	
Catalyst Loading	1.0 mol % Pd(dppf)Cl ₂	
Solvent Volume	8 L Toluene, 8 L Water	1:1 v/v
Reaction Temp.	85 °C (Internal)	
Reaction Time	4-6 hours	Monitor by LCMS
Expected Yield	1.05 - 1.17 kg	80-90%
Purity (by HPLC)	> 98.5%	After crystallization
Residual Pd	< 10 ppm	After carbon treatment

Visualizations

Suzuki-Miyaura Catalytic Cycle

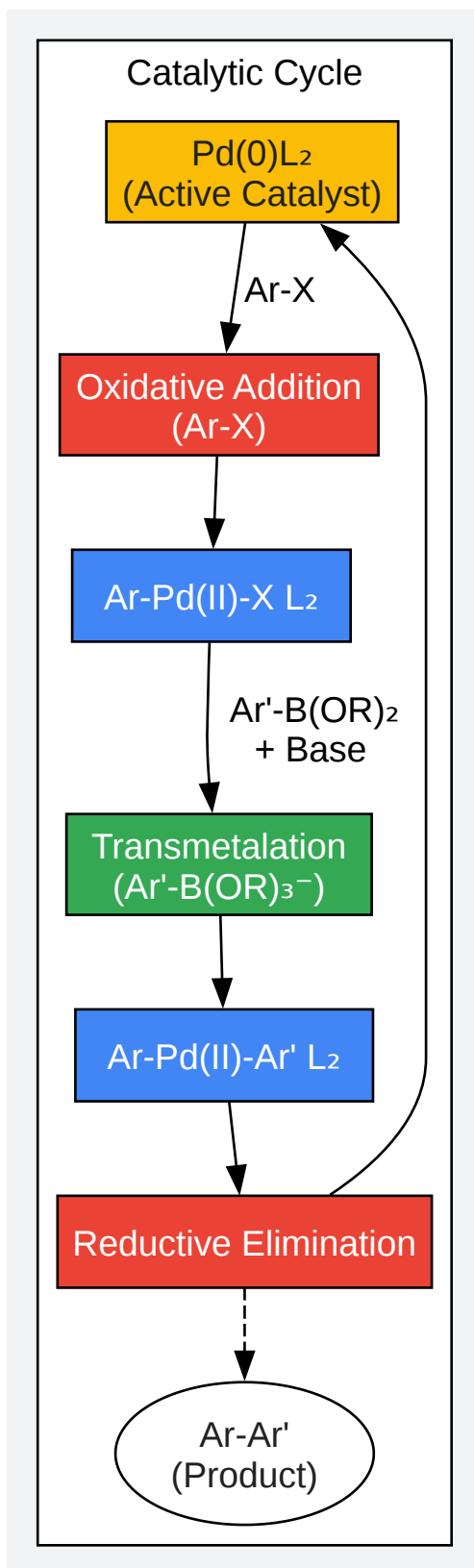

[Click to download full resolution via product page](#)

Caption: The catalytic cycle for the Suzuki-Miyaura cross-coupling reaction.

Pilot-Scale Synthesis Workflow

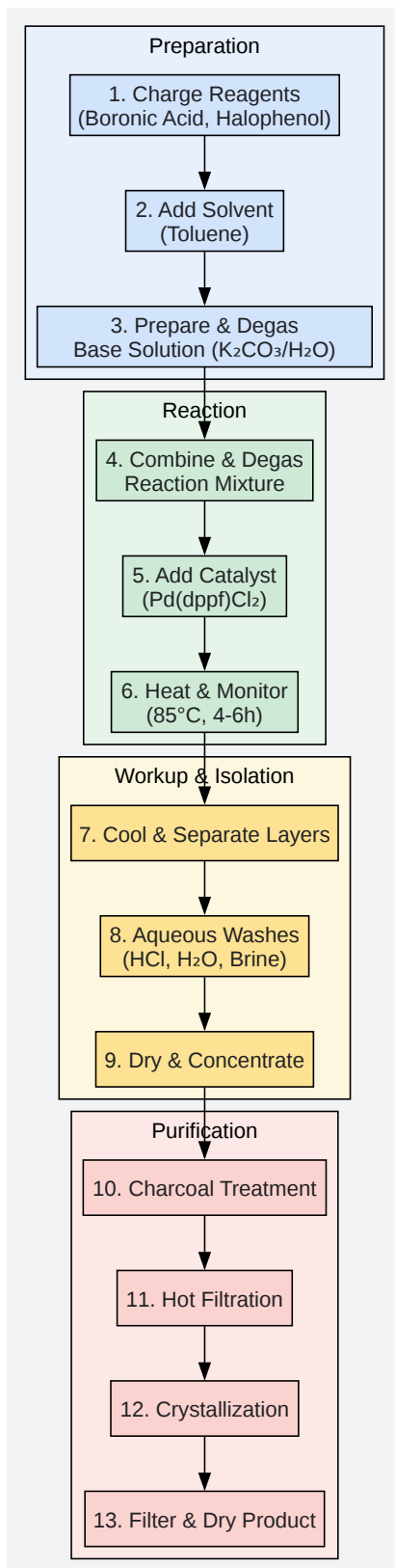

[Click to download full resolution via product page](#)

Caption: Step-by-step workflow for the pilot-scale synthesis of **o-(2-Naphthyl)phenol**.

References

- Method for preparing o-hydroxynaphthalene formaldehyde compound from naphthol derivative.
- 2-Naphthol Synthesis
- Suzuki-Miyaura cross-coupling: Practical Guide. Yoneda Labs.
- What is the proper way to set up a suzuki coupling? Reddit.
- The synthesis of 1 and 2-naphthols from Naphthalene. Sciencemadness Discussion Board.
- STUDIES IN 2-NAPHTHOL DERIV
- An Enantioselective Suzuki–Miyaura Coupling To Form Axially Chiral Biphenols. Journal of the American Chemical Society.
- Suzuki-Miyaura Coupling. Chemistry LibreTexts.
- Oxidation Reactions of 1-and 2-Naphthols: An Experimental and Theoretical Study.
- The Heck, Suzuki, and Olefin Metathesis Reactions. Master Organic Chemistry.
- **o-(2-Naphthyl)phenol** | C₁₆H₁₂O. PubChem.
- Diagnosing issues with a failed Suzuki coupling? Reddit.
- Evaluation of Potential Safety Hazards Associated with the Suzuki–Miyaura Cross-Coupling of Aryl Bromides with Vinylboron Species. Organic Process Research & Development.
- Suzuki Coupling. Organic Chemistry Portal.
- Purification and Characterization of 1-Naphthol-2-Hydroxylase from Carbaryl-Degrading Pseudomonas Strain C4.
- Synthesis of Naphthalenes and 2-Naphthols by the Electrophilic Cyclization of Alkynes.
- Process for removal of impurities from phenol by means of at least one acid catalyst.
- Potential Safety Hazards Associated with Pd- Catalyzed Cross-Coupling Reactions. Purdue University.
- How can I solve my problem with Suzuki coupling?

Need Custom Synthesis?

BenchChem offers custom synthesis for rare earth carbides and specific isotopic labeling.

Email: info@benchchem.com or [Request Quote Online](#).

Sources

- [1. chem.libretexts.org \[chem.libretexts.org\]](https://chem.libretexts.org)

- [2. masterorganicchemistry.com \[masterorganicchemistry.com\]](https://www.masterorganicchemistry.com)
- [3. Suzuki Coupling \[organic-chemistry.org\]](https://www.organic-chemistry.org)
- [4. engineering.purdue.edu \[engineering.purdue.edu\]](https://engineering.purdue.edu)
- [5. pubs.acs.org \[pubs.acs.org\]](https://pubs.acs.org)
- [6. Yoneda Labs \[yonedalabs.com\]](https://www.yonedalabs.com)
- [7. reddit.com \[reddit.com\]](https://www.reddit.com)
- [8. researchgate.net \[researchgate.net\]](https://www.researchgate.net)
- To cite this document: BenchChem. [Technical Support Center: Pilot-Scale Synthesis of o-(2-Naphthyl)phenol]. BenchChem, [2026]. [Online PDF]. Available at: [\[https://www.benchchem.com/product/b1608689/docs#technical-support-center-pilot-scale-synthesis-of-o-2-naphthyl-phenol\]](https://www.benchchem.com/product/b1608689/docs#technical-support-center-pilot-scale-synthesis-of-o-2-naphthyl-phenol)

Disclaimer & Data Validity:

The information provided in this document is for Research Use Only (RUO) and is strictly not intended for diagnostic or therapeutic procedures. While BenchChem strives to provide accurate protocols, we make no warranties, express or implied, regarding the fitness of this product for every specific experimental setup.

Technical Support: The protocols provided are for reference purposes. Unsure if this reagent suits your experiment?

Need Industrial/Bulk Grade? [Request Custom Synthesis Quote](#)

BenchChem

Our mission is to be the trusted global source of essential and advanced chemicals, empowering scientists and researchers to drive progress in science and industry.

Contact

Address: 3281 E Guasti Rd

Ontario, CA 91761, United States

Phone: (601) 213-4426

Email: info@benchchem.com

Contact our Ph.D. Support Team for a compatibility check