

Positional Isomerism in Dimethoxybenzyl Moieties: A Comparative Guide to Biological Activity

Author: BenchChem Technical Support Team. **Date:** May 2026

Compound of Interest

Compound Name:	<i>(2,3-Dimethoxy-benzyl)-(2-methoxy-1-methyl-ethyl)-amine</i>
CAS No.:	356090-87-4
Cat. No.:	B1608048

[Get Quote](#)

Introduction

In the landscape of medicinal chemistry and drug discovery, the seemingly subtle variation in the positioning of functional groups on an aromatic scaffold can lead to profound differences in biological activity. This principle is vividly illustrated by the dimethoxybenzyl isomers, specifically the 2,4-, 2,5-, and 3,4-dimethoxy substituted benzyl moieties. While direct comparative studies on the biological activities of the parent dimethoxybenzyl alcohols are not extensively documented in publicly available literature, a wealth of information on their varied derivatives provides a strong foundation for a comparative analysis. This guide offers an in-depth examination of how the isomeric arrangement of two methoxy groups on a benzyl scaffold influences the antioxidant, antimicrobial, cytotoxic, and enzyme-inhibiting properties of a diverse range of chemical compounds. Understanding these structure-activity relationships (SAR) is paramount for researchers, scientists, and drug development professionals aiming to rationally design novel therapeutic agents with enhanced potency and selectivity.[1][2][3]

The core structures under consideration are:

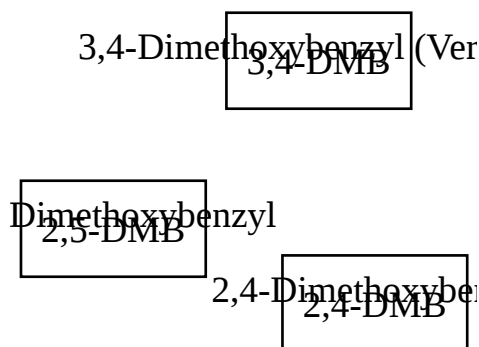

[Click to download full resolution via product page](#)

Caption: Chemical structures of the core dimethoxybenzyl isomers.

Comparative Analysis of Biological Activities

The positioning of the electron-donating methoxy groups on the benzene ring alters the molecule's electronic distribution, lipophilicity, and steric profile, thereby influencing its interaction with biological targets.

Antioxidant Activity

The antioxidant potential of phenolic and methoxy-substituted compounds is often attributed to their ability to donate a hydrogen atom or an electron to neutralize free radicals. The stability of the resulting radical is key to its efficacy. While direct comparative data for the dimethoxybenzyl alcohols is scarce, studies on related phenolic acids indicate that the arrangement of methoxy and hydroxyl groups significantly impacts antioxidant capacity. For instance, the presence of methoxy groups generally enhances antioxidant activity.^[4] The specific positioning influences the O-H bond dissociation enthalpy and the stability of the resulting radical, which are critical determinants of antioxidant potency in assays like the DPPH (2,2-diphenyl-1-picrylhydrazyl) radical scavenging assay.^{[5][6][7]}

A study on a related compound, 3,5-dihydroxy-4-methoxybenzyl alcohol (DHMBA), highlights the potent antioxidant effects of this substitution pattern, suggesting that the interplay of hydroxyl and methoxy groups is crucial.^{[4][8]}

Antimicrobial Activity

Dimethoxybenzyl moieties are found in various compounds with notable antimicrobial properties. The mechanism of action is often linked to the disruption of microbial cell membranes or the inhibition of essential enzymes.

For example, Veratryl alcohol (3,4-dimethoxybenzyl alcohol) has been identified as a quorum-sensing inhibitor (QSI) and exhibits antibacterial efficacy against *Pseudomonas aeruginosa*. It has been shown to inhibit the expression of quorum sensing-related genes and reduce the production of virulence factors.[9]

While direct comparisons are limited, the structure-activity relationship of various synthetic antimicrobial agents suggests that the substitution pattern on the benzyl ring is a critical factor in determining the spectrum and potency of activity. For instance, studies on benzyl bromide derivatives have shown that their antibacterial and antifungal efficacy is structure-dependent.[9]

Table 1: Comparison of Antimicrobial Activity of Dimethoxybenzyl Derivatives (Illustrative)

Compound Class	Isomer Moiety	Target Organism(s)	Activity Metric (e.g., MIC)	Reference
Benzyl Bromide Derivatives	Not specified	<i>S. aureus</i> , <i>S. pyogenes</i> , <i>E. faecalis</i> , <i>K. pneumoniae</i> , <i>S. typhi</i> , <i>E. coli</i> , <i>C. albicans</i>	MIC values ranging from 0.25 mg/mL to 4 mg/mL	[9]
Veratryl alcohol	3,4-Dimethoxybenzyl	<i>P. aeruginosa</i>	Inhibition of virulence factors at 512-1024 µg/mL	[9]

Note: This table is illustrative due to the lack of direct comparative studies on the isomers.

Cytotoxic Activity against Cancer Cells

The dimethoxybenzyl scaffold is a key component of numerous compounds investigated for their anticancer properties. The position of the methoxy groups plays a crucial role in their cytotoxic effects, often by influencing their ability to interact with targets like tubulin or to induce apoptosis.

For instance, a series of 4-substituted methoxybenzoyl-aryl-thiazoles demonstrated that a 3,4,5-trimethoxyphenyl group (closely related to the 3,4-dimethoxybenzyl structure) exhibited excellent inhibition against a range of cancer cells, with IC50 values in the nanomolar range. In contrast, a derivative with a 3,5-dimethoxyphenyl group showed significantly lower cytotoxicity. [6] This highlights the profound impact of the methoxy group positioning on anticancer potency.

Furthermore, a study on 3-chloro-2,5-dihydroxybenzyl alcohol, a derivative related to the 2,5-dimethoxybenzyl structure, demonstrated its ability to induce apoptosis in human cervical carcinoma (HeLa) cells by causing DNA damage.[10]

Table 2: Comparative Cytotoxicity of Dimethoxybenzyl-Containing Compounds

Compound	Isomeric Feature	Cell Line	IC50 Value	Reference
4-(3,4,5-trimethoxyphenyl) SMART compound	3,4,5-trimethoxy	Various cancer cells	21 - 71 nM	[6]
4-(3,5-dimethoxyphenyl) SMART compound	3,5-dimethoxy	Various cancer cells	170 - 424 nM	[6]
3-chloro-2,5-dihydroxybenzyl alcohol	2,5-dihydroxy	HeLa	~35 μM	[10]

Enzyme Inhibition

The dimethoxybenzyl structure is also found in inhibitors of various enzymes, with the substitution pattern influencing binding affinity and inhibitory potency. A notable example is the

inhibition of tyrosinase, a key enzyme in melanin synthesis. While direct comparative data on dimethoxybenzyl alcohol isomers as tyrosinase inhibitors is not readily available, studies on related compounds like p-hydroxybenzyl alcohol show that the benzyl alcohol moiety can effectively inhibit this enzyme.[11][12] The mechanism often involves binding to the enzyme's active site, leading to a conformational change that reduces its catalytic activity.[11]

The study of inhibitors for any given enzyme, such as tyrosinase, often reveals that subtle changes in the inhibitor's structure, including the position of substituents, can lead to significant differences in IC50 values.[13][14][15]

Structure-Activity Relationship (SAR): The Underlying Principles

The observed differences in the biological activities of dimethoxybenzyl isomers can be rationalized through key principles of structure-activity relationships:

- **Electronic Effects:** The electron-donating nature of the methoxy groups increases the electron density of the aromatic ring. The position of these groups (ortho, meta, para) influences the molecule's overall dipole moment and its ability to participate in electronic interactions with biological targets.
- **Steric Factors:** The placement of the methoxy groups can create steric hindrance, affecting how the molecule fits into the binding pocket of a receptor or an enzyme's active site.
- **Lipophilicity:** Methoxy groups increase the lipophilicity of the molecule compared to hydroxyl groups. The overall lipophilicity, influenced by the isomerism, affects the compound's ability to cross cell membranes and reach its intracellular target.

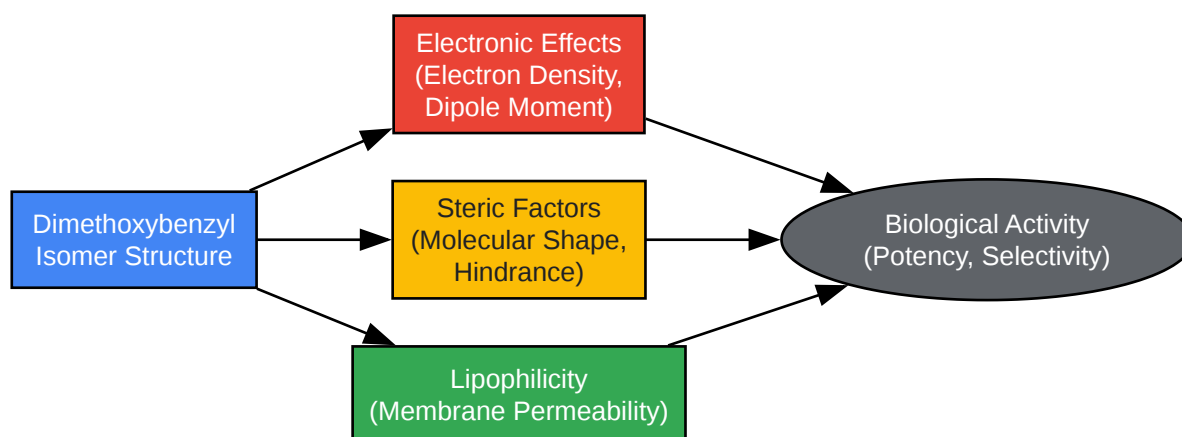

[Click to download full resolution via product page](#)

Caption: Key factors influencing the biological activity of dimethoxybenzyl isomers.

Experimental Protocols

To facilitate further research and comparative analysis, this section provides detailed methodologies for key in vitro assays.

DPPH (2,2-diphenyl-1-picrylhydrazyl) Radical Scavenging Assay

This assay is a standard method for evaluating the antioxidant activity of compounds.

Principle: DPPH is a stable free radical that absorbs light at 517 nm. In the presence of an antioxidant that can donate a hydrogen atom, the DPPH radical is reduced, leading to a decrease in absorbance.

Procedure:

- Preparation of Reagents:
 - Prepare a stock solution of DPPH in methanol (e.g., 0.1 mM).
 - Dissolve test compounds (dimethoxybenzyl isomers) and a positive control (e.g., ascorbic acid or Trolox) in methanol to create a series of concentrations.

- Assay Protocol:
 - In a 96-well microplate, add a specific volume of the test compound solution to each well.
 - Add the DPPH solution to each well and mix.
 - Incubate the plate in the dark at room temperature for 30 minutes.
- Data Analysis:
 - Measure the absorbance of each well at 517 nm using a microplate reader.
 - Calculate the percentage of radical scavenging activity using the formula: % Inhibition = $[(A_{\text{control}} - A_{\text{sample}}) / A_{\text{control}}] * 100$
 - Determine the IC₅₀ value, which is the concentration of the compound that scavenges 50% of the DPPH radicals, by plotting the percentage of inhibition against the compound concentration.^{[5][7]}

Minimum Inhibitory Concentration (MIC) Assay

The MIC assay is used to determine the lowest concentration of an antimicrobial agent that inhibits the visible growth of a microorganism.

Principle: A serial dilution of the antimicrobial agent is prepared in a liquid growth medium and inoculated with a standardized number of microorganisms. The growth is assessed after incubation.

Procedure:

- Preparation of Materials:
 - Prepare a sterile liquid growth medium (e.g., Mueller-Hinton Broth for bacteria).
 - Prepare a standardized inoculum of the test microorganism (e.g., to 0.5 McFarland standard).

- Dissolve the test compounds in a suitable solvent (e.g., DMSO) and prepare serial dilutions in the growth medium in a 96-well microplate.
- Inoculation and Incubation:
 - Inoculate each well with the standardized microbial suspension.
 - Include positive (microorganism without compound) and negative (medium only) controls.
 - Incubate the plate under appropriate conditions (e.g., 37°C for 24 hours for bacteria).
- Data Analysis:
 - Determine the MIC by visually inspecting the wells for turbidity. The MIC is the lowest concentration of the compound at which no visible growth is observed.[\[16\]](#)[\[17\]](#)[\[18\]](#)

Cytotoxicity Assay (MTT Assay)

The MTT (3-(4,5-dimethylthiazol-2-yl)-2,5-diphenyltetrazolium bromide) assay is a colorimetric assay for assessing cell viability.

Principle: Viable cells with active metabolism convert the yellow MTT into a purple formazan product. The amount of formazan produced is proportional to the number of viable cells.

Procedure:

- Cell Culture and Seeding:
 - Culture the desired cancer cell line (e.g., HeLa) in an appropriate medium.
 - Seed the cells in a 96-well plate at a suitable density and allow them to adhere overnight.
- Compound Treatment:
 - Treat the cells with various concentrations of the test compounds and a vehicle control.
 - Incubate for a specified period (e.g., 48 hours).
- MTT Addition and Formazan Solubilization:

- Add MTT solution to each well and incubate for a few hours to allow formazan crystal formation.
- Add a solubilizing agent (e.g., DMSO or a specialized buffer) to dissolve the formazan crystals.
- Data Analysis:
 - Measure the absorbance of the solubilized formazan at a specific wavelength (e.g., 570 nm).
 - Calculate the percentage of cell viability relative to the control and determine the IC50 value (the concentration that inhibits 50% of cell growth).

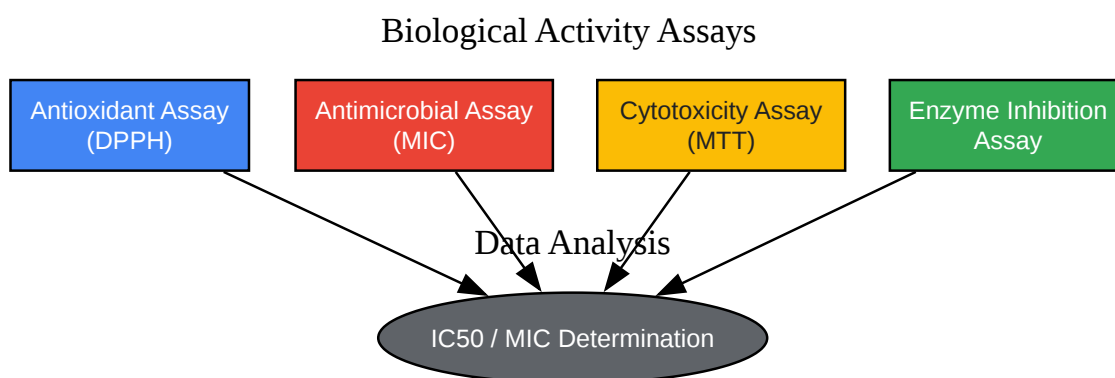

[Click to download full resolution via product page](#)

Caption: General workflow for assessing the biological activity of dimethoxybenzyl isomers.

Conclusion

While a direct head-to-head comparison of the biological activities of 2,4-, 2,5-, and 3,4-dimethoxybenzyl alcohol is not readily available in the current scientific literature, the extensive research on their derivatives provides compelling evidence for the critical role of isomeric substitution. The position of the two methoxy groups on the benzyl ring profoundly influences the electronic, steric, and lipophilic properties of the resulting molecules. This, in turn, dictates their interactions with biological targets, leading to significant variations in their antioxidant,

antimicrobial, cytotoxic, and enzyme-inhibiting activities. The 3,4-dimethoxy (veratryl) moiety, for example, is a recurring motif in compounds with interesting antimicrobial and anticancer properties. The principles of structure-activity relationships underscore the importance of precise structural modifications in the design of new therapeutic agents. Further research involving the direct comparative evaluation of these fundamental isomeric building blocks would be invaluable to the field of medicinal chemistry, providing a clearer roadmap for the rational design of more potent and selective drugs.

References

- IC50 values of the antioxidant activity test using DPPH method. ResearchGate. Available at: [\[Link\]](#).
- How Does 2,5-Dimethoxybenzyl Alcohol Interact With Other Chemicals? Knowledge. Available at: [\[Link\]](#).
- Assessing the toxic dose of the potent antioxidant 3,5-dihydroxy-4-methoxybenzyl alcohol in rats. PubMed. Available at: [\[Link\]](#).
- A Review of the Structure—Activity Relationship of Natural and Synthetic Antimetastatic Compounds. National Institutes of Health. Available at: [\[Link\]](#).
- Synthetic strategy and structure–activity relationship (SAR) studies of 3-(5'-hydroxymethyl-2'-furyl)-1-benzyl indazole (YC-1, Lifiquat): a review. PubMed Central. Available at: [\[Link\]](#).
- Structure–Activity Relationship Study of Biselyngbyolide B Reveals Mitochondrial Fission-Induced Cytotoxicity in Cancer. National Institutes of Health. Available at: [\[Link\]](#).
- Discovery of 4-Substituted Methoxybenzoyl-Aryl-Thiazole as Novel Anticancer Agents: Synthesis, Biological Evaluation and Structure-Activity Relationships. National Institutes of Health. Available at: [\[Link\]](#).
- Inhibitory effect of p-hydroxybenzyl alcohol on tyrosinase activity and melanogenesis. PubMed. Available at: [\[Link\]](#).
- DPPH Measurements and Structure—Activity Relationship Studies on the Antioxidant Capacity of Phenols. National Institutes of Health. Available at: [\[Link\]](#).

- Inhibitory Effect of p-Hydroxybenzyl Alcohol on Tyrosinase Activity and Melanogenesis. ResearchGate. Available at: [\[Link\]](#).
- IC50 values of antioxidant activities, DPPH and ABTS radical scavenging... ResearchGate. Available at: [\[Link\]](#).
- The Relationship between the IC50 Values and the Apparent Inhibition Constant in the Study of Inhibitors of Tyrosinase Diphenolase Activity Helps Confirm the Mechanism of Inhibition. MDPI. Available at: [\[Link\]](#).
- The Relationship between the IC50 Values and the Apparent Inhibition Constant in the Study of Inhibitors of Tyrosinase Diphenolase. MDPI. Available at: [\[Link\]](#).
- Variations in IC50 Values with Purity of Mushroom Tyrosinase. PubMed Central. Available at: [\[Link\]](#).
- Structure Activity Relationships. Drug Design Org. Available at: [\[Link\]](#).
- Comparative Effects of the Potent Antioxidant 3,5-Dihydroxy-4-methoxybenzyl Alcohol and Gallic Acid on the Growth and Death of RAW264.7 Macrophages and Lung Cancer A549 Cells In Vitro. MDPI. Available at: [\[Link\]](#).
- Structure-activity relationships for the design of small-molecule inhibitors. ResearchGate. Available at: [\[Link\]](#).
- 2,5-Dimethoxybenzyl alcohol. PubChem. Available at: [\[Link\]](#).
- Comparison of mushroom tyrosinase inhibitory abilities (IC50) among... ResearchGate. Available at: [\[Link\]](#).
- Testing the Effectiveness of Antimicrobials | Microbiology. Lumen Learning. Available at: [\[Link\]](#).
- Antimicrobial susceptibility testing to evaluate minimum inhibitory concentration values of clinically relevant antibiotics. PubMed Central. Available at: [\[Link\]](#).

- Antibacterial Activity of Different Compositions of Ethanol and Isopropanol in Hand Sanitizers. Kosmos Publishers. Available at: [[Link](#)].
- 3-Chloro-2,5-dihydroxybenzyl alcohol activates human cervical carcinoma HeLa cell apoptosis by inducing DNA damage. PubMed. Available at: [[Link](#)].
- Preparation and Applications of 4-Methoxybenzyl Esters in Organic Synthesis. PubMed Central. Available at: [[Link](#)].

Need Custom Synthesis?

BenchChem offers custom synthesis for rare earth carbides and specific isotopic labeling.

Email: info@benchchem.com or [Request Quote Online](#).

Sources

- 1. A Review of the Structure—Activity Relationship of Natural and Synthetic Antimetastatic Compounds - PMC [[pmc.ncbi.nlm.nih.gov](https://pubmed.ncbi.nlm.nih.gov)]
- 2. Structure Activity Relationships - Drug Design Org [drugdesign.org]
- 3. researchgate.net [researchgate.net]
- 4. Comparative Effects of the Potent Antioxidant 3,5-Dihydroxy-4-methoxybenzyl Alcohol and Gallic Acid on the Growth and Death of RAW264.7 Macrophages and Lung Cancer A549 Cells In Vitro [mdpi.com]
- 5. researchgate.net [researchgate.net]
- 6. DPPH Measurements and Structure—Activity Relationship Studies on the Antioxidant Capacity of Phenols - PMC [[pmc.ncbi.nlm.nih.gov](https://pubmed.ncbi.nlm.nih.gov)]
- 7. DPPH Radical Scavenging Assay [mdpi.com]
- 8. Assessing the toxic dose of the potent antioxidant 3,5-dihydroxy-4-methoxybenzyl alcohol in rats - PubMed [pubmed.ncbi.nlm.nih.gov]
- 9. dovepress.com [dovepress.com]
- 10. researchgate.net [researchgate.net]
- 11. Inhibitory effect of p-hydroxybenzyl alcohol on tyrosinase activity and melanogenesis - PubMed [pubmed.ncbi.nlm.nih.gov]

- [12. dpph assay ic50: Topics by Science.gov \[science.gov\]](#)
- [13. mdpi.com \[mdpi.com\]](#)
- [14. Variations in IC50 Values with Purity of Mushroom Tyrosinase - PMC \[pmc.ncbi.nlm.nih.gov\]](#)
- [15. researchgate.net \[researchgate.net\]](#)
- [16. Testing the Effectiveness of Antimicrobials | Microbiology \[courses.lumenlearning.com\]](#)
- [17. Antimicrobial susceptibility testing to evaluate minimum inhibitory concentration values of clinically relevant antibiotics - PMC \[pmc.ncbi.nlm.nih.gov\]](#)
- [18. kosmospublishers.com \[kosmospublishers.com\]](#)
- [To cite this document: BenchChem. \[Positional Isomerism in Dimethoxybenzyl Moieties: A Comparative Guide to Biological Activity\]. BenchChem, \[2026\]. \[Online PDF\]. Available at: \[https://www.benchchem.com/product/b1608048/docs#positional-isomerism-in-dimethoxybenzyl-moieties-a-comparative-guide-to-biological-activity\]](#)

Disclaimer & Data Validity:

The information provided in this document is for Research Use Only (RUO) and is strictly not intended for diagnostic or therapeutic procedures. While BenchChem strives to provide accurate protocols, we make no warranties, express or implied, regarding the fitness of this product for every specific experimental setup.

Technical Support: The protocols provided are for reference purposes. Unsure if this reagent suits your experiment?

Need Industrial/Bulk Grade? [Request Custom Synthesis Quote](#)

BenchChem

Our mission is to be the trusted global source of essential and advanced chemicals, empowering scientists and researchers to drive progress in science and industry.

Contact

Address: 3281 E Guasti Rd
Ontario, CA 91761, United States
Phone: (601) 213-4426
Email: info@benchchem.com

Contact our Ph.D. Support Team for a compatibility check