

Advanced Oxidation Protocols: The Tetraethylammonium Periodate (TEAP) System

Author: BenchChem Technical Support Team. **Date:** May 2026

Compound of Interest

Compound Name:	Tetraethylammonium periodate
CAS No.:	5492-69-3
Cat. No.:	B1608976

[Get Quote](#)

Executive Summary

Tetraethylammonium Periodate (TEAP) represents a critical evolution in oxidative chemistry, bridging the gap between the potent but insolubility-plagued inorganic periodates (e.g., NaIO_4) and the requirements of modern organic synthesis. Unlike its sodium counterpart, which demands aqueous or biphasic conditions often incompatible with lipophilic substrates, TEAP provides a source of the periodate anion (

) that is soluble in organic media such as chloroform, dichloromethane, and acetonitrile.

This guide details the mechanistic underpinnings of TEAP mediated oxidations, focusing on its three primary applications: vicinal diol cleavage, sulfide-to-sulfoxide conversion, and oxidative N-dealkylation. It is designed for researchers requiring high-fidelity control over oxidation states in complex molecule synthesis.

Physicochemical Profile & Synthesis

The utility of TEAP lies in its structure: a lipophilic tetraethylammonium cation paired with the hypervalent periodate anion. This pairing disrupts the rigid ionic lattice found in inorganic salts,

facilitating solvation in aprotic organic solvents.

Comparative Solubility Matrix

Solvent	Sodium Periodate (NaIO ₄)	Tetraethylammonium Periodate (TEAP)	Operational Consequence
Water	Soluble (High)	Soluble	TEAP can be prepared in aqueous media.
Dichloromethane	Insoluble	Soluble	Allows homogeneous oxidation of lipophilic drugs.
Chloroform	Insoluble	Soluble	Ideal for NMR-scale reaction monitoring.
Acetonitrile	Insoluble	Soluble	Standard solvent for kinetic studies.

Preparation Protocol

While commercially available, fresh preparation is recommended to ensure the absence of iodate impurities.

Protocol: Ion-Exchange Synthesis

- Stoichiometry: Dissolve 10 mmol of Sodium Periodate (NaIO₄) in 20 mL of distilled water.
- Cation Exchange: Separately, dissolve 10 mmol of Tetraethylammonium Bromide (Et₄NBr) in 10 mL of water.
- Precipitation/Extraction: Slowly add the bromide solution to the periodate solution.
 - Note: Depending on concentration and temperature, TEAP may precipitate. If not, extract the mixture exhaustively with Dichloromethane (mL).

- Purification: Dry the organic layer over anhydrous _____, filter, and evaporate the solvent under reduced pressure.
- Crystallization: Recrystallize the resulting solid from a DCM/Ether mixture to yield pure TEAP crystals.

Mechanistic Foundations

The Modified Malaprade Mechanism (Diol Cleavage)

In aqueous media, periodate cleavage of 1,2-diols is governed by the Malaprade mechanism. TEAP allows this reaction to proceed in anhydrous organic solvents, which is crucial for substrates prone to hydrolysis or hydration.

Key Mechanistic Feature: The reaction proceeds via a cyclic periodate ester. The lipophilic cation (

) acts as a phase transfer catalyst or solubilizing agent, bringing the

into close proximity with the diol in the organic phase.

Figure 1: Mechanism of Diol Cleavage by TEAP

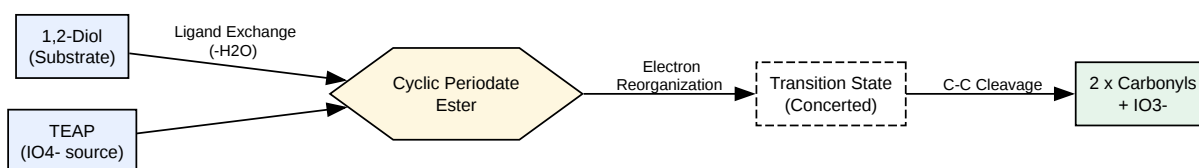

[Click to download full resolution via product page](#)

Caption: The cyclic ester formation is the rate-determining step in sterically hindered systems. The reaction is specific to syn-diols or those capable of achieving a syn-conformation.

Electrophilic Sulfur Oxidation

TEAP is a selective reagent for transforming sulfides to sulfoxides. Unlike peroxides, which can over-oxidize to sulfones or react with other sensitive groups, TEAP offers controlled oxygen

transfer.

Mechanism: The periodate oxygen acts as an electrophile attacking the nucleophilic sulfur atom.[1][2] The polar transition state is stabilized by the organic solvent dielectric, preventing "runaway" oxidation.

Figure 2: Sulfide to Sulfoxide Pathway

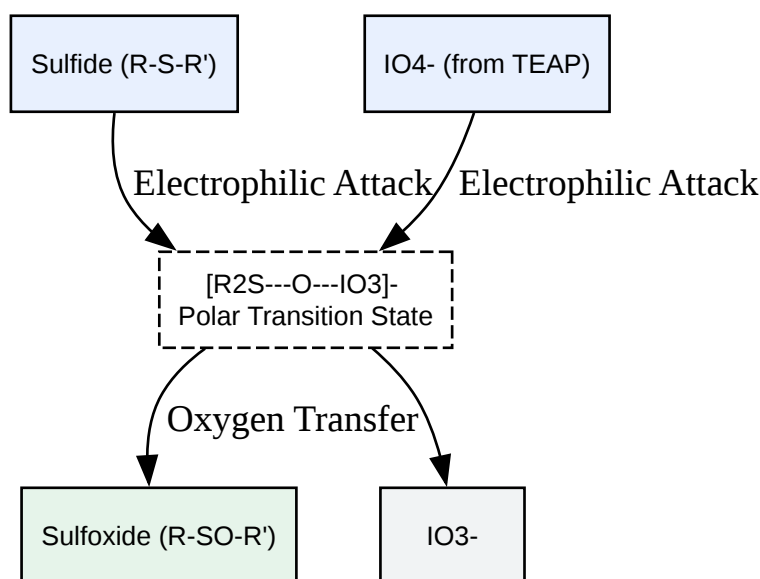

[Click to download full resolution via product page](#)

Caption: Direct oxygen transfer avoids radical intermediates common in peroxide oxidations, preserving stereocenters elsewhere in the molecule.

Catalytic Oxidative N-Dealkylation

A specialized application of TEAP involves the oxidative dealkylation of tertiary amines, often catalyzed by iron(III) porphyrins or similar complexes. This mimics Cytochrome P450 activity.

Pathway:

- Electron Transfer: The amine undergoes Single Electron Transfer (SET) to the high-valent metal-oxo species (generated by TEAP), forming an aminium radical cation.
- Proton Loss: Loss of a proton from the

-carbon yields a carbon-centered radical.

- Oxygen Rebound: Rapid oxygen transfer generates a carbinolamine.
- Collapse: The carbinolamine collapses to release the secondary amine and an aldehyde.

Experimental Protocols

General Procedure for Diol Cleavage

Target: Cleavage of trans-1,2-cyclohexanediol to hexane-1,6-dial.

- Setup: In a round-bottom flask, dissolve 1.0 mmol of the diol in 10 mL of dry Dichloromethane (DCM).
- Addition: Add 1.1 mmol of TEAP in a single portion.
- Reaction: Stir at room temperature under nitrogen.
 - Monitoring: The reaction is typically fast (15–60 mins). Monitor by TLC (disappearance of diol).
- Workup: Filter the mixture through a short pad of silica gel to remove the inorganic iodate by-product (which precipitates or adsorbs). Rinse with Ether.^[3]
- Isolation: Concentrate the filtrate to yield the dialdehyde.

Selective Sulfide Oxidation

Target: Oxidation of Thioanisole to Methyl phenyl sulfoxide.

- Setup: Dissolve 1.0 mmol Thioanisole in 5 mL Acetonitrile.
- Addition: Add 1.05 mmol TEAP at 0°C.
- Reaction: Allow to warm to room temperature over 30 minutes.
- Quench: Add 1 mL saturated aqueous
if excess oxidant remains.

- Extraction: Extract with Ethyl Acetate, wash with brine, dry over

Safety & Handling

- Oxidizer Hazard: TEAP is a strong oxidant. Do not heat dry crystals above 100°C or grind with reducing agents (sulfur, metal powders), as this may cause fire or explosion.
- Toxicity: Quaternary ammonium salts can be toxic if ingested or absorbed. Wear nitrile gloves and work in a fume hood.
- Storage: Store in a cool, dry place away from light. Decomposition to iodate can occur over prolonged exposure to moisture.

References

- Preparation and Properties of Quaternary Ammonium Periodates Source: Qureshi, A. K., & Sklarz, B. (1966). Journal of the Chemical Society C: Organic. Context: Foundational work establishing the solubility and reactivity profiles of tetraalkylammonium periodates in organic solvents. Link:[\[Link\]](#)[3]
- Mechanisms of Periodate Oxidation of Glycols Source: Buist, G. J., & Bunton, C. A. (1954). Journal of the Chemical Society. Context: Detailed kinetic analysis of the cyclic ester intermediate (Malaprade mechanism) applicable to organic periodate systems. Link:[\[Link\]](#)[3][4][5]
- Oxidative N-Dealkylation using **Tetraethylammonium Periodate** Source: Rebelo, S. L. H., et al. (2016). Australian Journal of Chemistry. Context: Describes the specific use of TEAP and iron catalysts for P450-mimetic N-dealkylation. Link:[\[Link\]](#)
- Selective Oxidation of Sulfides to Sulfoxides Source: Varma, R. S., et al. (1986). Tetrahedron Letters. Context: While often citing NaIO₄ on supports, this establishes the electrophilic nature of the periodate attack on sulfur which TEAP replicates in solution. Link:[\[Link\]](#)

Need Custom Synthesis?

BenchChem offers custom synthesis for rare earth carbides and specific isotopic labeling.

Email: info@benchchem.com or [Request Quote Online](#).

Sources

- [1. Effective Oxidation of Sulfides to Sulfoxides with Hydrogen Peroxide under Transition-Metal-Free Conditions - PMC \[pmc.ncbi.nlm.nih.gov\]](#)
- [2. researchgate.net \[researchgate.net\]](#)
- [3. Organic Syntheses Procedure \[orgsyn.org\]](#)
- [4. pubs.acs.org \[pubs.acs.org\]](#)
- [5. researchgate.net \[researchgate.net\]](#)
- To cite this document: BenchChem. [Advanced Oxidation Protocols: The Tetraethylammonium Periodate (TEAP) System]. BenchChem, [2026]. [Online PDF]. Available at: [<https://www.benchchem.com/product/b1608976/docs#advanced-oxidation-protocols-the-tetraethylammonium-periodate-teap-system>]

Disclaimer & Data Validity:

The information provided in this document is for Research Use Only (RUO) and is strictly not intended for diagnostic or therapeutic procedures. While BenchChem strives to provide accurate protocols, we make no warranties, express or implied, regarding the fitness of this product for every specific experimental setup.

Technical Support: The protocols provided are for reference purposes. Unsure if this reagent suits your experiment?

Need Industrial/Bulk Grade? [Request Custom Synthesis Quote](#)

BenchChem

Our mission is to be the trusted global source of essential and advanced chemicals, empowering scientists and researchers to drive progress in science and industry.

Contact

Address: 3281 E Guasti Rd

Ontario, CA 91761, United States

Phone: (601) 213-4426

Email: info@benchchem.com

[Contact our Ph.D. Support Team for a compatibility check](#)