

Advanced Functionalization Strategies for the 3-Azepan-2-yl-quinoline Scaffold

Author: BenchChem Technical Support Team. **Date:** May 2026

Compound of Interest

Compound Name: 3-Azepan-2-yl-quinoline

CAS No.: 527673-83-2

Cat. No.: B1608411

[Get Quote](#)

Executive Summary

The fusion of a quinoline moiety with a medium-sized saturated heterocycle, specifically the 3-(azepan-2-yl)quinoline core, represents a high-value pharmacophore in modern drug discovery. This scaffold bridges the flat, aromatic DNA-intercalating/kinase-binding potential of the quinoline with the three-dimensional, flexible spatial projection of the seven-membered azepane ring.

Unlike the ubiquitous piperidine or pyrrolidine analogs, the azepane ring offers unique conformational entropy and hydrophobic bulk, often resulting in improved selectivity profiles for GPCRs (e.g., Serotonin 5-HT receptors) and kinase targets. However, the steric congestion at the biaryl linkage (Quinoline-C3 and Azepane-C2) presents specific synthetic challenges.

This Application Note provides a validated, modular workflow for diversifying this core. We focus on three vectors of functionalization:

- Vector A: Modulation of the Azepane Nitrogen (The "Warhead" Vector).
- Vector B: Late-Stage C-H Functionalization of the Quinoline (The "Tuning" Vector).

- Vector C: Stereochemical Resolution of the C2' Center.

Structural Analysis & Retrosynthetic Logic

The **3-Azepan-2-yl-quinoline** core possesses two distinct domains: the Lipophilic Anchor (Quinoline) and the Solubilizing/Interaction Domain (Azepane).

- The Linkage Challenge: The bond between an sp^2 hybridized aromatic carbon (Quinoline C3) and an sp^3 hybridized secondary alkyl carbon (Azepane C2) is metabolically stable but synthetically demanding due to the potential for β -hydride elimination during cross-coupling.
- Conformational Lock: The C3-substitution pattern forces the azepane ring out of planarity with the quinoline, creating a distinct "twisted" topology that can exploit specific hydrophobic pockets in protein targets.

Strategic Workflow Diagram

The following diagram outlines the divergent synthesis strategy employed in this protocol.

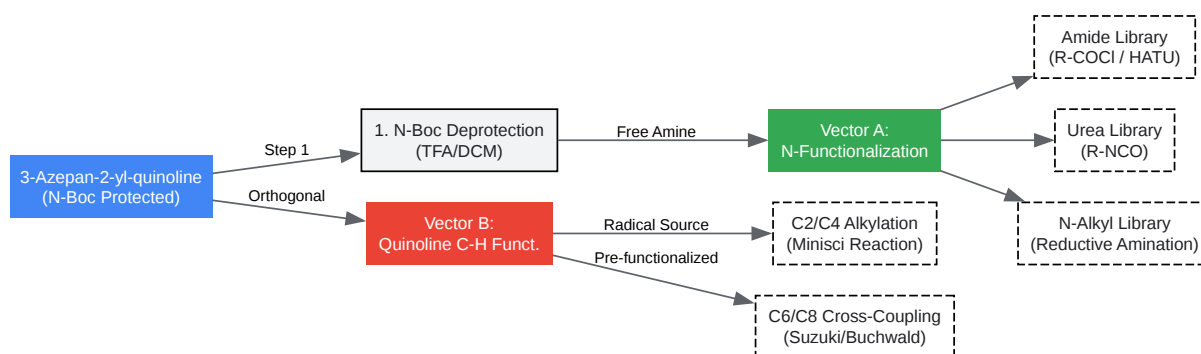

[Click to download full resolution via product page](#)

Figure 1: Divergent functionalization strategy for the **3-Azepan-2-yl-quinoline** scaffold. Vector A addresses the aliphatic amine, while Vector B modifies the aromatic core.

Experimental Protocols

Protocol A: Scaffold Synthesis (The "Anchor")

Note: If the core is not commercially available, this Negishi Cross-Coupling method is the industry standard for linking secondary cyclic amines to heteroaromatics.

Objective: Synthesize tert-butyl 2-(quinolin-3-yl)azepane-1-carboxylate.

Reagents:

- 3-Bromoquinoline (1.0 equiv)
- N-Boc-2-iodo-azepane (precursor for zinc reagent)
- Zinc dust (activated)
- Pd(OAc)₂ / S-Phos (Catalyst system)
- Solvent: Anhydrous THF/Toluene (1:1)

Procedure:

- **Zincate Formation:** In a flame-dried Schlenk flask under Argon, treat N-Boc-2-iodo-azepane (1.2 equiv) with activated Zinc dust in THF at 40°C for 2 hours to generate the organozinc reagent. Critical: Ensure iodine is stabilized; Knochel-type conditions are recommended.
- **Coupling:** To a separate flask, add 3-Bromoquinoline (1.0 equiv), Pd(OAc)₂ (2 mol%), and S-Phos (4 mol%). Add the organozinc solution via cannula.
- **Reaction:** Heat to 60°C for 12 hours. Monitor by LCMS for the disappearance of the bromide.
- **Workup:** Quench with saturated NH₄Cl. Extract with EtOAc. Purify via flash chromatography (Hexane/EtOAc).

Validation:

- ¹H NMR (400 MHz, CDCl₃): Look for the diagnostic multiplet of the Azepane-H2 proton at ~4.8 ppm and the Quinoline-H2 singlet at ~8.9 ppm.

Protocol B: Vector A - Nitrogen Diversification (High-Throughput)

Targeting the Azepane Nitrogen for SAR exploration.

Prerequisite: Deprotect the N-Boc core using 20% TFA in DCM (1 hr, RT), followed by basic workup (NaHCO_3) to isolate the free amine.

Workflow 1: Reductive Amination (N-Alkylation)

This method is preferred over direct alkylation to avoid over-alkylation (quaternization).

- Preparation: Dissolve 3-(azepan-2-yl)quinoline (0.1 mmol) in DCE (1 mL) in a 1-dram vial.
- Addition: Add the desired Aldehyde/Ketone (1.2 equiv). Stir for 30 mins to form the imine/iminium species.
- Reduction: Add $\text{NaBH}(\text{OAc})_3$ (1.5 equiv) and one drop of Acetic Acid. Cap and shake at RT for 16 hours.
- Quench: Add 1 mL 1M NaOH. Vortex and separate the organic layer.
- Purification: Pass the organic layer through a SCX-2 (Strong Cation Exchange) cartridge. Wash with MeOH, elute product with 2M NH_3 in MeOH.

Workflow 2: Urea Formation (Restricted Rotation)

Ureas often improve metabolic stability and H-bond donor capability.

- Preparation: Dissolve core amine (0.1 mmol) and DIPEA (2.0 equiv) in DCM.
- Addition: Add Isocyanate R-NCO (1.1 equiv) at 0°C.
- Reaction: Warm to RT and stir for 2 hours.
- Workup: Wash with 1M HCl (to remove unreacted amine core) and Brine. Concentrate.

Protocol C: Vector B - Quinoline C-H Functionalization (Minisci Reaction)

Direct alkylation of the electron-deficient Quinoline ring (Positions C2 and C4).

Mechanism: Radical nucleophilic substitution of a protonated heteroaromatic base. Scientific Insight: The azepane ring is bulky. Minisci reactions are sensitive to sterics. Expect substitution primarily at C4 (para to the nitrogen) or C2 (ortho to nitrogen), but the C3-azepane group will sterically shield C2 and C4 to some degree. C2 is the most activated but most hindered. C4 is the likely major isomer.

Reagents:

- 3-(Azepan-2-yl)quinoline (N-Boc protected to prevent radical attack on the amine)
- Alkyl Carboxylic Acid (Radical source, e.g., Pivalic acid, Cyclopropanecarboxylic acid)
- Ammonium Persulfate ((NH₄)₂S₂O₈)
- Silver Nitrate (AgNO₃) - Catalyst
- Solvent: DCM/Water biphasic system or TFA/Water.

Step-by-Step:

- Setup: Dissolve N-Boc-core (0.2 mmol) in DCM (2 mL) and Water (1 mL). Add TFA (2 equiv) to protonate the quinoline nitrogen (activating it).
- Radical Source: Add the Alkyl Carboxylic Acid (3.0 equiv).
- Catalyst: Add AgNO₃ (0.2 equiv).
- Initiation: Add (NH₄)₂S₂O₈ (3.0 equiv) in one portion.
- Reaction: Stir vigorously at 40°C for 4-6 hours. Evolution of CO₂ gas indicates decarboxylation.
- Workup: Basify with NaOH to pH > 9. Extract with DCM.

- Analysis: Analyze regiochemistry by NOESY NMR. The C2-proton signal (usually ~8.9 ppm) will disappear if C2 functionalization occurred.

Data Summary & QC Specifications

Parameter	Specification	Method	Acceptance Criteria
Purity	>95%	UPLC-MS (254 nm)	No single impurity >2%
Identity	Structure Verification	¹ H NMR (DMSO-d ₆)	Integration of Azepane H2 (1H) vs Quinoline H2 (1H) = 1:1
Chirality	Enantiomeric Excess (ee)	Chiral SFC	>98% ee (if resolved)
Residual Metal	Pd / Zn	ICP-MS	< 10 ppm (for biological assays)

Troubleshooting Table:

Observation	Root Cause	Corrective Action
Low Yield in Negishi (Protocol A)	Inactive Zinc / Moisture	Use Rieke Zinc or activate Zn with TMSCl/BrCH ₂ CH ₂ Br. Ensure strictly anhydrous THF.
Regioisomers in Minisci (Protocol C)	Low sterics on radical	Use bulkier radicals (t-Butyl, Adamantyl) to favor C4 over C2 if selectivity is poor.
Incomplete Amide Coupling (Vector A)	Steric hindrance at Azepane N	Switch coupling reagent from HATU to COMU or use Acid Chloride/Pyridine method.

References

- Quinoline Functionalization

- Blakemore, D. C., et al. "Organic synthesis provides opportunities to transform drug discovery." [1][2] *Nature Chemistry* 2018, 10, 383–394. [Link](#)
- Detailed review on Minisci reactions: Duncton, M. A. J. "Minisci reactions: Versatile CH-functionalizations for medicinal chemists." *Med.* [1][2][3][4][5] *Chem. Commun.* 2011, 2, 1135-1161. [Link](#)
- Azepane Scaffold Synthesis
 - Recent advances in azepane synthesis: Mykura, R. C., et al. "Synthesis of polysubstituted azepanes by dearomative ring expansion of nitroarenes." [3] *Nature Chemistry* 2024. [3] [Link](#)
 - Cross-coupling of secondary amines: Han, W., et al. "Pd-Catalyzed Cross-Coupling of Secondary Alkylzinc Reagents with Heteroaryl Halides." *J. Am. Chem. Soc.* [1] 2009, 131, 7532. [Link](#)
- Biological Relevance (Quinoline-Azepane)
 - Kinase Inhibition: Examples of fused azepane-heterocycles in kinase inhibitors (e.g., Balanol analogs). [6] Snieckus, V., et al. "Synthesis of the protein kinase C inhibitor balanol." *J. Org.* [1][7] *Chem.* 2000. [8] [Link](#)

Disclaimer: All protocols involve hazardous chemicals. Standard PPE and fume hood usage are mandatory. The "**3-Azepan-2-yl-quinoline**" core may be subject to intellectual property restrictions in specific jurisdictions; ensure FTO (Freedom to Operate) before commercial application.

Need Custom Synthesis?

BenchChem offers custom synthesis for rare earth carbides and specific isotopic labeling.

Email: info@benchchem.com or [Request Quote Online](#).

Sources

- [1. semanticscholar.org \[semanticscholar.org\]](https://www.semanticscholar.org)

- [2. pure.manchester.ac.uk \[pure.manchester.ac.uk\]](https://pure.manchester.ac.uk)
- [3. researchgate.net \[researchgate.net\]](https://researchgate.net)
- [4. researchgate.net \[researchgate.net\]](https://researchgate.net)
- [5. Recent advances in functionalized quinoline scaffolds and hybrids—Exceptional pharmacophore in therapeutic medicine - PMC \[pmc.ncbi.nlm.nih.gov\]](https://pubmed.ncbi.nlm.nih.gov/)
- [6. Synthesis of Functionalized Azepines via Cu\(I\)-Catalyzed Tandem Amination/Cyclization Reaction of Fluorinated Allenynes - PMC \[pmc.ncbi.nlm.nih.gov\]](https://pubmed.ncbi.nlm.nih.gov/)
- [7. Quinoline synthesis \[organic-chemistry.org\]](https://www.organic-chemistry.org)
- [8. pubs.acs.org \[pubs.acs.org\]](https://pubs.acs.org)
- To cite this document: BenchChem. [Advanced Functionalization Strategies for the 3-Azepan-2-yl-quinoline Scaffold]. BenchChem, [2026]. [Online PDF]. Available at: [\[https://www.benchchem.com/product/b1608411/docs#advanced-functionalization-strategies-for-the-3-azepan-2-yl-quinoline-scaffold\]](https://www.benchchem.com/product/b1608411/docs#advanced-functionalization-strategies-for-the-3-azepan-2-yl-quinoline-scaffold)

Disclaimer & Data Validity:

The information provided in this document is for Research Use Only (RUO) and is strictly not intended for diagnostic or therapeutic procedures. While BenchChem strives to provide accurate protocols, we make no warranties, express or implied, regarding the fitness of this product for every specific experimental setup.

Technical Support: The protocols provided are for reference purposes. Unsure if this reagent suits your experiment?

Need Industrial/Bulk Grade? [Request Custom Synthesis Quote](#)

BenchChem

Our mission is to be the trusted global source of essential and advanced chemicals, empowering scientists and researchers to drive progress in science and industry.

Contact

Address: 3281 E Guasti Rd
Ontario, CA 91761, United States
Phone: (601) 213-4426
Email: info@benchchem.com

Contact our Ph.D. Support Team for a compatibility check