

Technical Support Center: Ethyltriphenyltin Reagent Compatibility Guide

Author: BenchChem Technical Support Team. **Date:** May 2026

Compound of Interest

Compound Name: Ethyltriphenyltin

CAS No.: 5424-25-9

Cat. No.: B1607041

[Get Quote](#)

Prepared by: Gemini, Senior Application Scientist

Welcome to the technical support center for **ethyltriphenyltin**. This guide is designed for researchers, scientists, and drug development professionals to provide in-depth, field-proven insights into the safe and effective use of this organotin reagent. Our goal is to move beyond simple protocols and explain the chemical causality behind reagent choices, ensuring the integrity and success of your experiments.

Frequently Asked Questions (FAQs)

Q1: What are the primary classes of chemical reagents that are incompatible with **ethyltriphenyltin**?

Ethyltriphenyltin, like many tetraorganotin compounds, is relatively stable compared to its halide or hydride counterparts. However, its reactivity profile necessitates careful consideration of reaction partners to avoid degradation and hazardous situations. The primary classes of incompatible reagents are strong oxidizing agents, strong acids, and certain electrophiles, particularly halogens.^{[1][2]} The carbon-tin bond, while relatively non-polar, is susceptible to cleavage by these types of reagents.^[2]

Q2: I'm planning a reaction with a strong oxidizing agent. Why is this a problem with **ethyltriphenyltin**?

Causality: Strong oxidizing agents can lead to the cleavage of the carbon-tin bonds and/or oxidation of the tin(IV) center. The reactions of organotin compounds, particularly those with tin-tin bonds (which can be present as impurities or formed in situ), can involve scission with oxidizing agents like peroxides.[2] This process is often exothermic and can lead to a rapid, uncontrolled decomposition of the organotin reagent, generating a mixture of tin oxides and organic byproducts. This not only destroys your reagent but can also pose a safety risk and contaminate your desired product.

Troubleshooting:

- Symptom: Upon addition of an oxidizing agent (e.g., nitric acid, permanganates, peroxides), you observe a rapid temperature increase, gas evolution, or the formation of a white precipitate (likely tin oxides).
- Solution: Avoid using strong oxidizing agents directly with **ethyltriphenyltin**. If an oxidation step is required in your synthetic sequence, it should be performed on the product after the organotin-mediated step and subsequent purification to remove all tin residues.

Q3: What is the mechanism of degradation when **ethyltriphenyltin** is exposed to strong acids?

Causality: The carbon-tin bond in **ethyltriphenyltin** is susceptible to cleavage by strong mineral acids (e.g., HCl, H₂SO₄).[2] This reaction, known as protodestannylation, involves the protonation and subsequent displacement of one of the organic groups. The aryl (phenyl) groups are generally cleaved more readily than the alkyl (ethyl) groups.[2]

The general mechanism can be depicted as: $\text{Ph}_3\text{Sn}(\text{Et}) + \text{HX} \rightarrow \text{Ph}_2\text{Sn}(\text{Et})\text{X} + \text{PhH}$

This reaction consumes your reagent and forms undesired organotin halide byproducts (e.g., triphenyltin chloride if HCl is used), which can complicate the reaction workup and product purification.[3][4]

Troubleshooting:

- Symptom: Your reaction yield is low, and NMR or LC-MS analysis shows the presence of benzene and various organotin halide species.
- Solution: Buffer your reaction medium if acidic conditions are unavoidable. Use non-protic solvents.[5] If an acid catalyst is required, consider using a milder Lewis acid that is less likely to cause C-Sn bond cleavage.

Table 1: Summary of Incompatible Reagent Classes with **Ethyltriphenyltin**

Incompatible Reagent Class	Example(s)	Potential Reaction / Hazard	Prevention & Mitigation Strategy
Strong Oxidizing Agents	Peroxides, KMnO ₄ , HNO ₃	Rapid, exothermic decomposition; cleavage of C-Sn bonds; formation of tin oxides.[2]	Perform oxidation steps on purified products, not in the presence of the organotin reagent.
Strong/Mineral Acids	HCl, H ₂ SO ₄ , HBr	Protodestannylation (cleavage of C-Sn bonds) to form organotin halides and arenes/alkanes.[2]	Use aprotic solvents; buffer the reaction mixture; consider alternative Lewis acid catalysts.
Halogens / Electrophiles	Br ₂ , I ₂ , Cl ₂	Electrophilic cleavage of C-Sn bonds, leading to the formation of organotin halides and haloorganics.[2]	Protect the reaction from adventitious electrophiles. If a halogen is a necessary reactant, consider a different synthetic route.
Water / Moisture	H ₂ O (especially with catalysts or impurities)	While generally stable, prolonged exposure or the presence of impurities can lead to slow hydrolysis, forming stannoxanes.[1][3]	Use anhydrous solvents and handle under an inert atmosphere (e.g., nitrogen or argon).[1]

Q4: How do electrophiles, such as elemental halogens, react with ethyltriphenyltin?

The reaction with electrophiles is a key reactivity pathway for tetraorganotin compounds. Halogens like bromine (Br_2) or iodine (I_2) can readily cleave the carbon-tin bonds.[2] This process is a classic example of electrophilic substitution on a metal. The reaction proceeds stepwise, with the phenyl groups being more susceptible to cleavage than the ethyl group.

Reaction Visualization: The diagram below illustrates the initial cleavage of a phenyl group from ethyltriphenyltin by a halogen molecule (X_2), a common and potent electrophile.

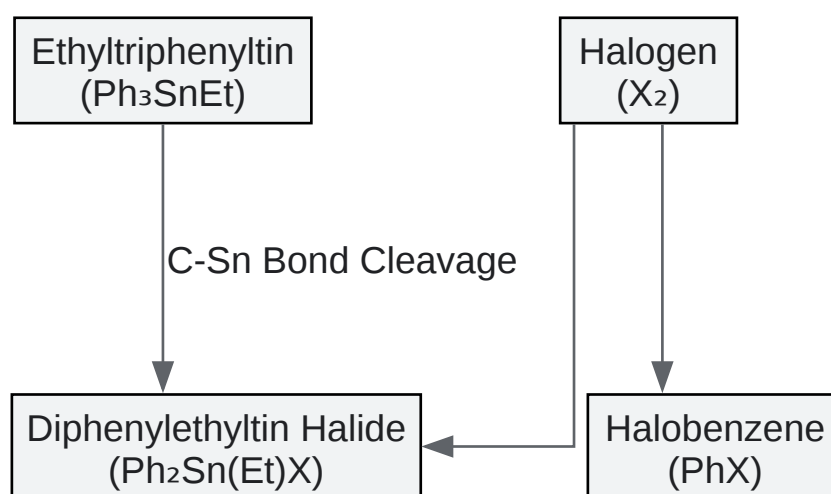

[Click to download full resolution via product page](#)

Caption: Electrophilic cleavage of a C-Sn bond.

Troubleshooting & Experimental Protocols

Q5: My reaction failed or gave a low yield. How can I determine if a reagent incompatibility was the cause?

When a reaction involving ethyltriphenyltin fails, a systematic troubleshooting approach is crucial. Use the following decision tree to diagnose potential incompatibility issues.

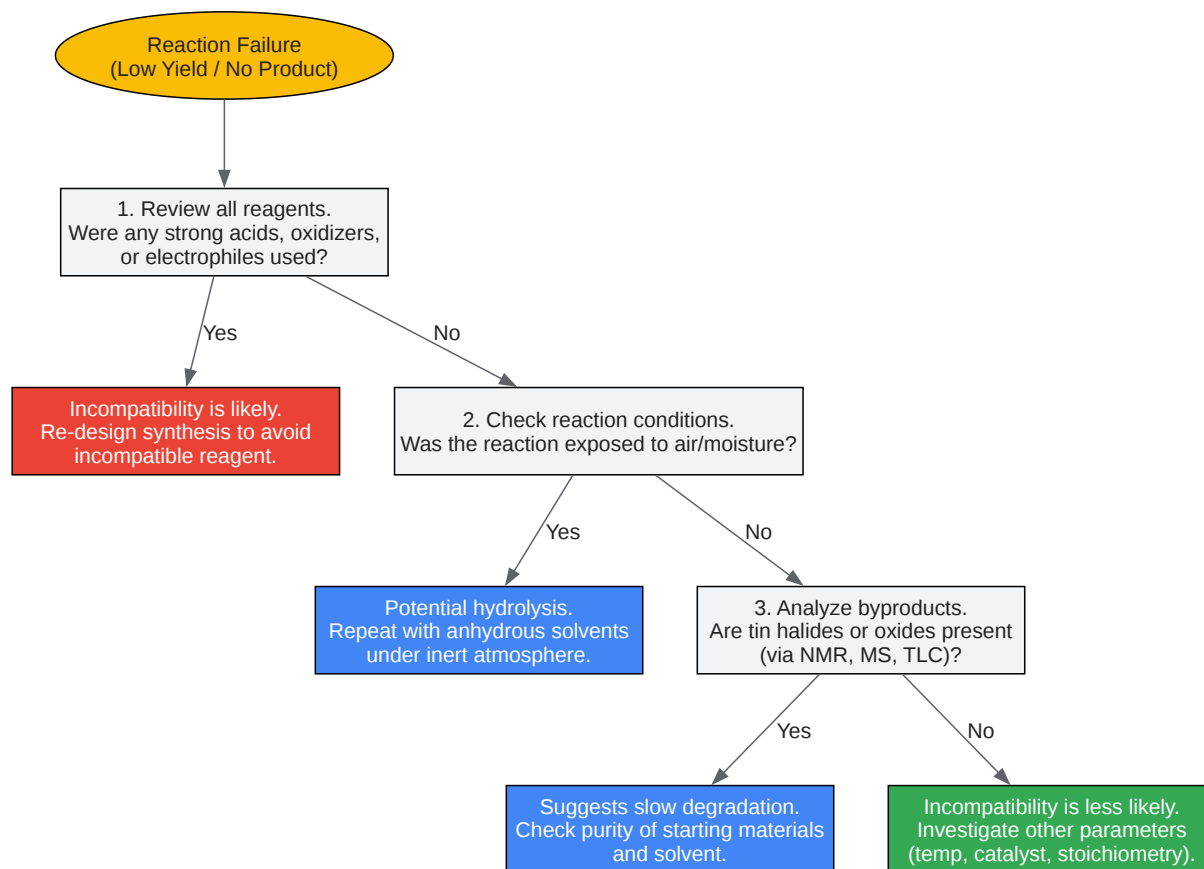

[Click to download full resolution via product page](#)

Need Custom Synthesis?

BenchChem offers custom synthesis for rare earth carbides and specific isotopic labeling.

Email: info@benchchem.com or [Request Quote Online](#).

Sources

- [1. fishersci.com](https://fishersci.com) [fishersci.com]
- [2. gelest.com](https://gelest.com) [gelest.com]
- [3. Organotin chemistry - Wikipedia](https://en.wikipedia.org) [en.wikipedia.org]
- [4. benchchem.com](https://benchchem.com) [benchchem.com]
- [5. nvlpubs.nist.gov](https://nvlpubs.nist.gov) [nvlpubs.nist.gov]
- To cite this document: BenchChem. [Technical Support Center: Ethyltriphenyltin Reagent Compatibility Guide]. BenchChem, [2026]. [Online PDF]. Available at: [\[https://www.benchchem.com/product/b1607041/docs#technical-support-center-ethyltriphenyltin-reagent-compatibility-guide\]](https://www.benchchem.com/product/b1607041/docs#technical-support-center-ethyltriphenyltin-reagent-compatibility-guide)

Disclaimer & Data Validity:

The information provided in this document is for Research Use Only (RUO) and is strictly not intended for diagnostic or therapeutic procedures. While BenchChem strives to provide accurate protocols, we make no warranties, express or implied, regarding the fitness of this product for every specific experimental setup.

Technical Support: The protocols provided are for reference purposes. Unsure if this reagent suits your experiment?

Need Industrial/Bulk Grade? [Request Custom Synthesis Quote](#)

BenchChem

Our mission is to be the trusted global source of essential and advanced chemicals, empowering scientists and researchers to drive progress in science and industry.

Contact

Address: 3281 E Guasti Rd

Ontario, CA 91761, United States

Phone: (601) 213-4426

Email: info@benchchem.com

[Contact our Ph.D. Support Team for a compatibility check](#)