

Predicted Biological Targets of Isobutyranilide: An In-depth Technical Guide

Author: BenchChem Technical Support Team. **Date:** May 2026

Compound of Interest

Compound Name: *Isobutyranilide*

CAS No.: 4406-41-1

Cat. No.: B1607330

[Get Quote](#)

For Researchers, Scientists, and Drug Development Professionals

Introduction

Isobutyranilide, a molecule with a core anilide structure, has emerged as a scaffold of interest in medicinal chemistry and agrochemical research. This technical guide provides a comprehensive overview of the predicted biological targets of **isobutyranilide** and its derivatives, summarizing key quantitative data, detailing experimental methodologies, and visualizing associated cellular pathways and workflows. The information presented herein is intended to facilitate further research and development of **isobutyranilide**-based compounds.

Predicted Biological Targets

Based on current research, two primary biological targets have been identified for derivatives of **isobutyranilide**: Topoisomerase II and Succinate Dehydrogenase.

Topoisomerase II Inhibition

A significant body of evidence points towards topoisomerase II as a key intracellular target for certain **isobutyranilide** derivatives. Specifically, 4-(1,2-diarylbut-1-en-1-yl)**isobutyranilides** have been synthesized and evaluated for their potential as anticancer agents. These compounds have demonstrated cytotoxic effects in various human tumor cell lines, and their mechanism of action is suggested to involve the inhibition of topoisomerase II, an essential enzyme in DNA replication and chromosome segregation.[1]

The following tables summarize the cytotoxic activity (IC50 values) of various **isobutyranilide** derivatives against a panel of human cancer cell lines and their direct inhibitory effect on topoisomerase II.

Table 1: Cytotoxicity of 4-(1,2-diarylbut-1-en-1-yl)**isobutyranilide** Derivatives[1]

Compound	MCF-7 (μM)	HeLa (μM)	A2780 (μM)	OVCAR5 (μM)
6g	1.5 ± 0.2	2.1 ± 0.3	1.8 ± 0.1	2.5 ± 0.4
6h	> 50	> 50	> 50	> 50
6i	3.2 ± 0.5	4.5 ± 0.6	3.9 ± 0.4	5.1 ± 0.7

Table 2: Topoisomerase II Inhibitory Activity of **Isobutyranilide** Derivatives[2]

Compound	Topoisomerase II IC50 (μM)
6d	2.26
6f	0.97
Etoposide (control)	0.34

The inhibition of topoisomerase II by **isobutyranilide** derivatives stabilizes the enzyme-DNA cleavage complex. This leads to the accumulation of double-strand breaks in the DNA, which triggers a DNA damage response. Consequently, cell cycle arrest and the activation of apoptotic pathways are induced, ultimately leading to programmed cell death.

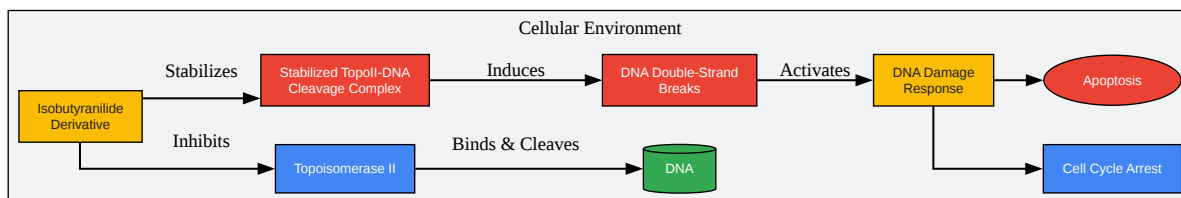

[Click to download full resolution via product page](#)

Figure 1. Proposed signaling pathway of **isobutyranilide** derivatives targeting Topoisomerase II.

Succinate Dehydrogenase (SDH) Inhibition

The fungicide isofetamid, which shares structural similarities with **isobutyranilide**, is a known inhibitor of succinate dehydrogenase (SDH), or mitochondrial complex II. This enzyme is a key component of both the citric acid cycle and the electron transport chain. By inhibiting SDH, isofetamid disrupts fungal respiration and energy production. This mode of action strongly suggests that **isobutyranilide** and its derivatives may also function as SDH inhibitors.

While direct IC50 values for **isobutyranilide** against SDH are not readily available in the public domain, the following table provides IC50 values for other known SDH inhibitors, offering a point of reference for potential potency.

Table 3: IC50 Values of Selected SDH Inhibitors[3][4]

Compound	Target Organism/Enzyme	IC50 (µM)
SDH-IN-6	Rhizoctonia solani SDH	11.76
SDH-IN-15	Fungal SDH	2.04
SDH-IN-31	Fungal SDH	1.11
Atpenin A5	Human SDH	0.0037

Inhibition of SDH by **isobutyranilide**-like compounds would block the oxidation of succinate to fumarate in the Krebs cycle. This would, in turn, impede the transfer of electrons to the electron transport chain, leading to a decrease in ATP production and ultimately cellular dysfunction and death in susceptible organisms.

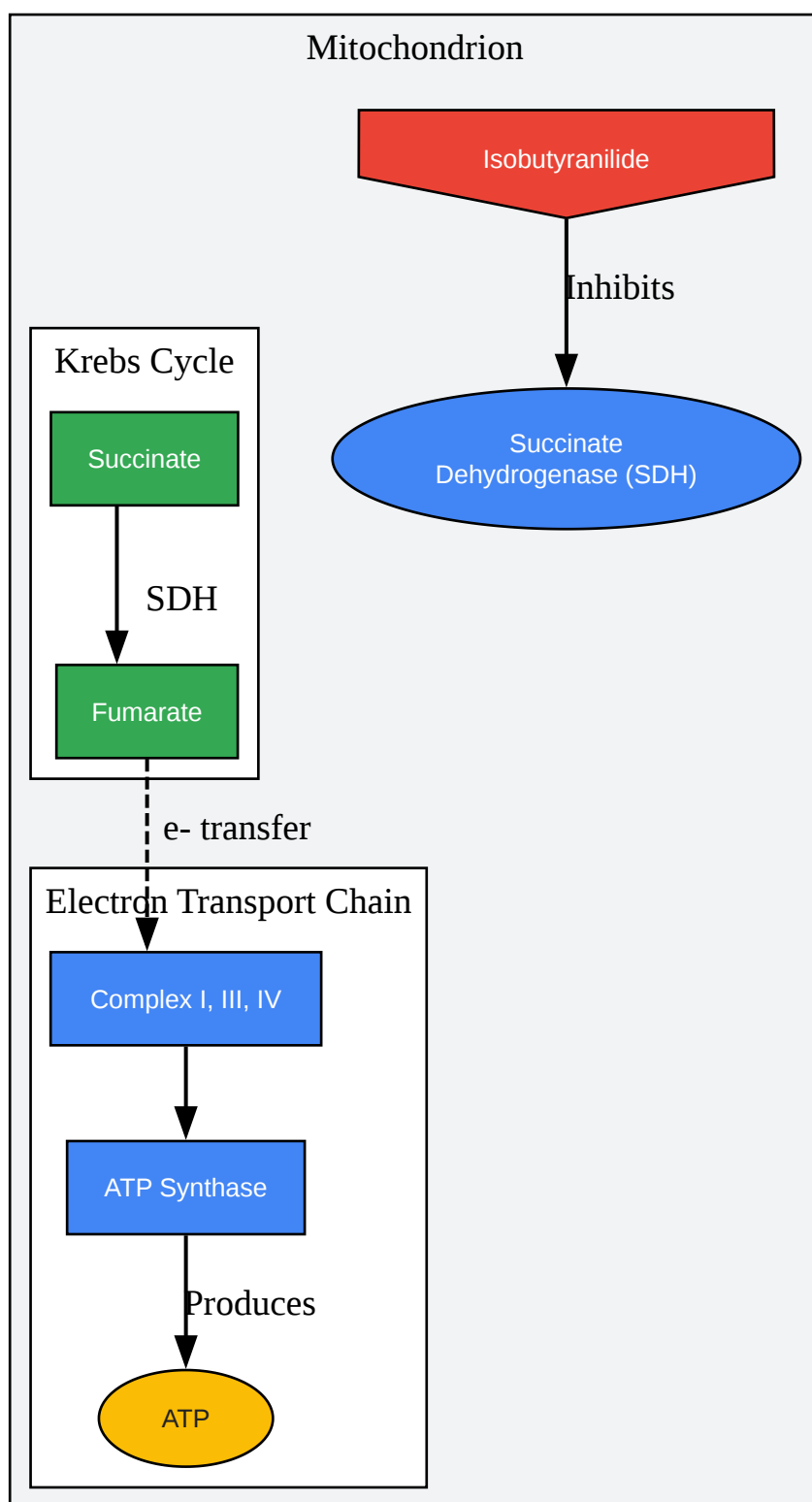

[Click to download full resolution via product page](#)

Figure 2. Proposed mechanism of SDH inhibition by **isobutyranilide**-like compounds.

Experimental Protocols

This section provides detailed methodologies for the key experiments cited in the investigation of **isobutyranilide**'s biological targets.

Topoisomerase II Inhibition Assay (DNA Decatenation Assay)

This assay is a standard method to measure the catalytic activity of Topoisomerase II, which involves the decatenation (unlinking) of kinetoplast DNA (kDNA).^{[5][6]}

Workflow Diagram

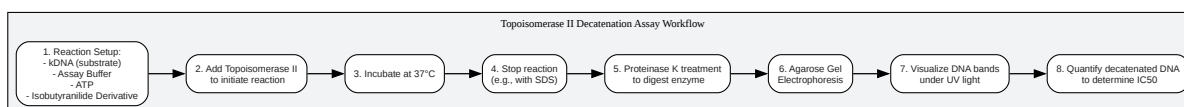

[Click to download full resolution via product page](#)

Figure 3. Workflow for a Topoisomerase II DNA decatenation assay.

Methodology

- **Reaction Mixture Preparation:** In a microcentrifuge tube, combine kinetoplast DNA (kDNA), assay buffer (typically containing Tris-HCl, KCl, MgCl₂, DTT, and BSA), and ATP. Add the **isobutyranilide** derivative at various concentrations.
- **Enzyme Addition:** Initiate the reaction by adding purified human Topoisomerase II enzyme.
- **Incubation:** Incubate the reaction mixture at 37°C for a specified time (e.g., 30 minutes).
- **Reaction Termination:** Stop the reaction by adding a stop solution, which often contains SDS.

- Protein Digestion: Treat the mixture with Proteinase K to digest the topoisomerase II enzyme.
- Gel Electrophoresis: Load the samples onto an agarose gel.
- Visualization: After electrophoresis, stain the gel with an intercalating dye (e.g., ethidium bromide) and visualize the DNA bands under UV light. Catenated kDNA remains in the well, while decatenated DNA migrates into the gel.
- Data Analysis: Quantify the intensity of the decatenated DNA bands. The IC₅₀ value is the concentration of the inhibitor that reduces the decatenation activity by 50%.^[5]

Succinate Dehydrogenase (SDH) Activity Assay

This colorimetric assay measures SDH activity by monitoring the reduction of an artificial electron acceptor, 2,6-dichlorophenolindophenol (DCPIP).^{[7][8]}

Workflow Diagram

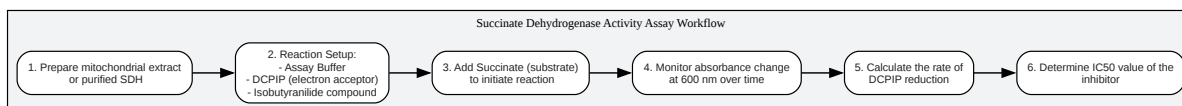

[Click to download full resolution via product page](#)

Figure 4. Workflow for a colorimetric SDH activity assay.

Methodology

- Sample Preparation: Isolate mitochondria from cells or tissues, or use a purified SDH enzyme preparation.
- Reaction Mixture Preparation: In a 96-well plate, add the assay buffer, DCPIP, and the test compound (e.g., **isobutyranilide**) at various concentrations.

- Reaction Initiation: Start the reaction by adding the substrate, succinate.
- Absorbance Measurement: Immediately begin monitoring the decrease in absorbance at 600 nm using a microplate reader. The blue color of oxidized DCPIP fades as it is reduced.
- Rate Calculation: Calculate the rate of the reaction based on the change in absorbance over time.
- Data Analysis: Plot the reaction rates against the inhibitor concentrations to determine the IC50 value, which is the concentration of the compound that inhibits SDH activity by 50%.[8]

Conclusion

The available evidence strongly suggests that **isobutyranilide** derivatives are promising candidates for targeting both topoisomerase II in cancer cells and succinate dehydrogenase in pathogenic fungi. The quantitative data presented provides a foundation for structure-activity relationship studies, and the detailed experimental protocols offer a clear path for further investigation and validation of these biological targets. The signaling pathways and workflows visualized in this guide aim to provide a clear conceptual framework for researchers in the field. Further studies are warranted to explore the full therapeutic and agrochemical potential of this versatile chemical scaffold.

Need Custom Synthesis?

BenchChem offers custom synthesis for rare earth carbides and specific isotopic labeling.

Email: info@benchchem.com or [Request Quote Online](#).

References

- [1. 4-\(1,2-diarylbut-1-en-1-yl\)isobutyranilide derivatives as inhibitors of topoisomerase II - PubMed \[pubmed.ncbi.nlm.nih.gov\]](#)
- [2. researchgate.net \[researchgate.net\]](#)
- [3. medchemexpress.com \[medchemexpress.com\]](#)
- [4. medchemexpress.com \[medchemexpress.com\]](#)
- [5. benchchem.com \[benchchem.com\]](#)

- [6. Topoisomerase Assays - PMC \[pmc.ncbi.nlm.nih.gov\]](#)
- [7. sigmaaldrich.com \[sigmaaldrich.com\]](#)
- [8. benchchem.com \[benchchem.com\]](#)
- To cite this document: BenchChem. [Predicted Biological Targets of Isobutyranilide: An In-depth Technical Guide]. BenchChem, [2026]. [Online PDF]. Available at: [\[https://www.benchchem.com/product/b1607330/docs#predicted-biological-targets-of-isobutyranilide-an-in-depth-technical-guide\]](https://www.benchchem.com/product/b1607330/docs#predicted-biological-targets-of-isobutyranilide-an-in-depth-technical-guide)

Disclaimer & Data Validity:

The information provided in this document is for Research Use Only (RUO) and is strictly not intended for diagnostic or therapeutic procedures. While BenchChem strives to provide accurate protocols, we make no warranties, express or implied, regarding the fitness of this product for every specific experimental setup.

Technical Support: The protocols provided are for reference purposes. Unsure if this reagent suits your experiment?

Need Industrial/Bulk Grade? [Request Custom Synthesis Quote](#)

BenchChem

Our mission is to be the trusted global source of essential and advanced chemicals, empowering scientists and researchers to drive progress in science and industry.

Contact

Address: 3281 E Guasti Rd
Ontario, CA 91761, United States
Phone: (601) 213-4426
Email: info@benchchem.com

[Contact our Ph.D. Support Team for a compatibility check](#)

