

Application Notes and Protocols: Ethyltriphenyltin in Cross-Coupling Reactions

Author: BenchChem Technical Support Team. **Date:** May 2026

Compound of Interest

Compound Name: Ethyltriphenyltin

CAS No.: 5424-25-9

Cat. No.: B1607041

[Get Quote](#)

Introduction: The Strategic Advantage of Ethyltriphenyltin in Palladium-Catalyzed Cross-Coupling

The Stille cross-coupling reaction stands as a cornerstone of modern organic synthesis, enabling the formation of carbon-carbon bonds with remarkable functional group tolerance and predictability.[1] Central to this transformation is the organostannane reagent, which acts as the nucleophilic partner in the catalytic cycle.[2] While symmetrical tetraorganostannanes and trialkyl(aryl/vinyl)stannanes have been extensively utilized, the use of mixed-group tetraorganostannanes, such as **ethyltriphenyltin** (Ph_3SnEt), offers a unique combination of reactivity, atom economy, and strategic deployment of organic moieties.

This application note provides a detailed guide for researchers, chemists, and drug development professionals on the effective use of **ethyltriphenyltin** in Stille cross-coupling reactions. We will delve into the mechanistic rationale for its use, provide detailed protocols for its synthesis and application, and offer insights into optimizing reaction conditions and ensuring safe handling.

Scientific Principles: Why Ethyltriphenyltin?

The utility of an unsymmetrical tetraorganostannane like **ethyltriphenyltin** hinges on the differential migratory aptitude of its organic groups during the transmetalation step of the Stille catalytic cycle.^[3] The generally accepted order of group transfer from tin to palladium is:

Alkynyl > Alkenyl > Aryl > Allyl = Benzyl > α -alkoxyalkyl > Alkyl^[3]

In **ethyltriphenyltin**, we have three phenyl groups (aryl) and one ethyl group (alkyl). Based on the established migratory aptitude, the phenyl group is significantly more reactive and will preferentially transfer to the palladium center, leaving the ethyl group behind on the tin byproduct. This key feature makes **ethyltriphenyltin** an effective phenyl-group transfer agent.

The primary advantages of using **ethyltriphenyltin** include:

- **Selective Phenyl Transfer:** The predictable transfer of the phenyl group allows for the precise construction of biaryl and other phenylated structures.
- **Air and Moisture Stability:** Like many organostannanes, **ethyltriphenyltin** is relatively stable to air and moisture, facilitating easier handling compared to more sensitive organometallic reagents.^{[1][2]}
- **Broad Substrate Scope:** The Stille reaction is renowned for its tolerance of a wide array of functional groups, a benefit that extends to reactions employing **ethyltriphenyltin**.^[4]

Synthesis of Ethyltriphenyltin: A Reliable Protocol

Ethyltriphenyltin can be readily synthesized in the laboratory from commercially available starting materials. The most common and reliable method involves the reaction of triphenyltin chloride with an ethyl Grignard reagent, such as ethylmagnesium bromide.

Protocol 1: Synthesis of Ethyltriphenyltin

Materials:

- Triphenyltin chloride (Ph_3SnCl)
- Magnesium turnings

- Ethyl bromide (bromoethane)
- Anhydrous diethyl ether or tetrahydrofuran (THF)
- Anhydrous hexane
- Saturated aqueous ammonium chloride (NH₄Cl) solution
- Anhydrous magnesium sulfate (MgSO₄) or sodium sulfate (Na₂SO₄)

Procedure:

- Preparation of Ethylmagnesium Bromide:
 - In a flame-dried, three-necked round-bottom flask equipped with a reflux condenser, a dropping funnel, and a nitrogen inlet, place magnesium turnings (1.2 equivalents).
 - Add a small volume of anhydrous diethyl ether or THF to just cover the magnesium.
 - Add a small crystal of iodine or a few drops of 1,2-dibromoethane to initiate the reaction.
 - Slowly add a solution of ethyl bromide (1.1 equivalents) in anhydrous diethyl ether or THF via the dropping funnel at a rate that maintains a gentle reflux.
 - After the addition is complete, stir the mixture at room temperature for 1-2 hours to ensure complete formation of the Grignard reagent.
- Reaction with Triphenyltin Chloride:
 - In a separate flame-dried flask under a nitrogen atmosphere, dissolve triphenyltin chloride (1.0 equivalent) in anhydrous diethyl ether or THF.
 - Cool the triphenyltin chloride solution to 0 °C using an ice bath.
 - Slowly add the freshly prepared ethylmagnesium bromide solution to the triphenyltin chloride solution via a cannula or dropping funnel.

- After the addition is complete, allow the reaction mixture to warm to room temperature and stir for 12-16 hours.
- Workup and Purification:
 - Cool the reaction mixture to 0 °C and slowly quench by the dropwise addition of saturated aqueous ammonium chloride solution.
 - Transfer the mixture to a separatory funnel and extract the aqueous layer with diethyl ether or ethyl acetate (3x).
 - Combine the organic layers and wash with brine.
 - Dry the organic layer over anhydrous magnesium sulfate or sodium sulfate, filter, and concentrate under reduced pressure to obtain the crude product.
 - The crude **ethyltriphenyltin** can be purified by vacuum distillation or recrystallization from a suitable solvent such as ethanol or hexane to yield a white crystalline solid.

Application in Stille Cross-Coupling: A General Protocol

The following protocol outlines a general procedure for the Stille cross-coupling of an aryl halide with **ethyltriphenyltin** to form a biaryl product. Reaction conditions should be optimized for specific substrates.

Protocol 2: Palladium-Catalyzed Stille Cross-Coupling of an Aryl Bromide with Ethyltriphenyltin

Materials:

- Aryl bromide (1.0 equivalent)
- **Ethyltriphenyltin** (1.1-1.5 equivalents)
- Palladium catalyst (e.g., Pd(PPh₃)₄, Pd₂(dba)₃) (1-5 mol%)

- Ligand (if necessary, e.g., PPh_3 , AsPh_3)
- Anhydrous solvent (e.g., toluene, DMF, dioxane)
- Optional additives: CuI (10-20 mol%), LiCl (2-3 equivalents)
- Aqueous potassium fluoride (KF) solution (for workup)

Procedure:

- Reaction Setup:
 - To a flame-dried Schlenk flask under a nitrogen or argon atmosphere, add the aryl bromide (1.0 equivalent), palladium catalyst (e.g., $\text{Pd}(\text{PPh}_3)_4$, 2 mol%), and any optional additives like CuI (10 mol%).
 - Add the anhydrous solvent (e.g., toluene) via syringe.
 - Add **ethyltriphenyltin** (1.2 equivalents) to the reaction mixture.
 - Degas the reaction mixture by bubbling nitrogen or argon through the solution for 10-15 minutes, or by three freeze-pump-thaw cycles.
- Reaction Execution:
 - Heat the reaction mixture to the desired temperature (typically 80-110 °C) and monitor the reaction progress by TLC or GC-MS.
 - Upon completion, cool the reaction mixture to room temperature.
- Workup and Purification:
 - Dilute the reaction mixture with an organic solvent like ethyl acetate or diethyl ether.
 - To remove the tin byproducts, stir the organic solution vigorously with a saturated aqueous solution of potassium fluoride (KF) for 1-2 hours. A precipitate of **ethyltriphenyltin** fluoride will form.

- Filter the mixture through a pad of Celite®, washing with the organic solvent.
- Transfer the filtrate to a separatory funnel, wash with water and then with brine.
- Dry the organic layer over anhydrous magnesium sulfate or sodium sulfate, filter, and concentrate under reduced pressure.
- Purify the crude product by flash column chromatography on silica gel to afford the desired biaryl product.

Data Presentation and Optimization

The success of a Stille coupling reaction is highly dependent on the choice of catalyst, ligand, solvent, and any additives. The following table provides a starting point for optimization.

Parameter	Recommended Starting Conditions	Rationale and Optimization Considerations
Palladium Catalyst	Pd(PPh ₃) ₄ (1-5 mol%) or Pd ₂ (dba) ₃ (1-2.5 mol%) with a ligand	Pd(PPh ₃) ₄ is often effective for a wide range of substrates. For more challenging couplings, a combination of a Pd(0) source like Pd ₂ (dba) ₃ and a specific ligand may be required.
Ligand	PPh ₃ , AsPh ₃ , P(2-furyl) ₃	The choice of ligand can significantly impact the rate of the reaction. Electron-rich phosphines generally accelerate oxidative addition, while more electron-neutral or electron-poor ligands can favor transmetalation and reductive elimination.
Solvent	Toluene, Dioxane, DMF, NMP	Toluene is a good general-purpose solvent. More polar aprotic solvents like DMF or NMP can accelerate the reaction, particularly the transmetalation step. ^[3]
Temperature	80-110 °C	Higher temperatures are often required to drive the reaction to completion, but should be minimized to prevent side reactions like catalyst decomposition or homocoupling.
Additives	CuI (10-20 mol%), LiCl (2-3 eq.)	CuI can act as a co-catalyst, accelerating the transmetalation step. LiCl can also increase the reaction rate, especially in less polar

solvents like THF, by promoting the dissociation of the halide from the palladium center.[3]

Visualization of Key Processes

Stille Catalytic Cycle

The following diagram illustrates the generally accepted mechanism for the Stille cross-coupling reaction.

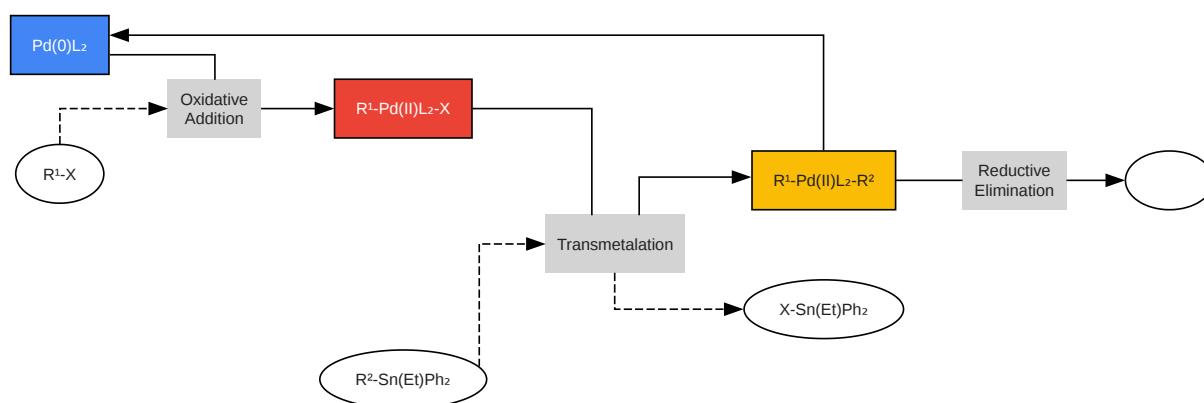

[Click to download full resolution via product page](#)

Caption: Catalytic cycle of the Stille cross-coupling reaction.

Experimental Workflow

This diagram outlines the general workflow for performing a Stille cross-coupling reaction using ethyltriphenyltin.

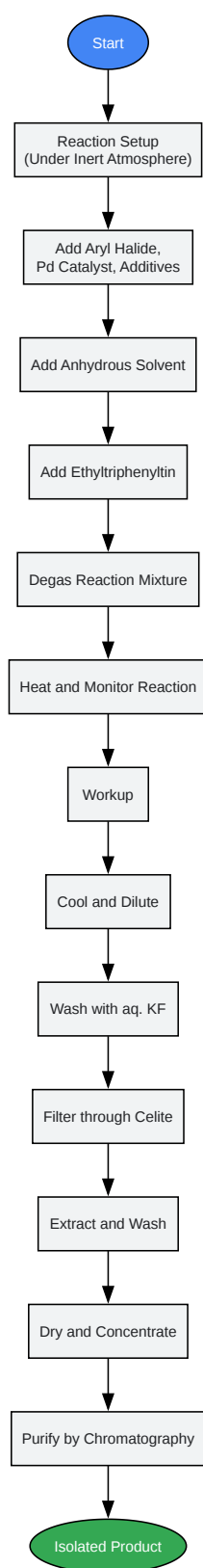

[Click to download full resolution via product page](#)

Caption: General experimental workflow for Stille coupling.

Safety and Handling

Organotin compounds, including **ethyltriphenyltin**, are toxic and should be handled with appropriate safety precautions.

- Toxicity: **Ethyltriphenyltin** is toxic if swallowed, in contact with skin, or if inhaled. It is also very toxic to aquatic life with long-lasting effects.
- Handling:
 - Always work in a well-ventilated fume hood.
 - Wear appropriate personal protective equipment (PPE), including chemical-resistant gloves, safety goggles, and a lab coat.
 - Avoid inhalation of dust or vapors.
 - Prevent contact with skin and eyes.
 - In case of accidental exposure, seek immediate medical attention.
- Waste Disposal: All organotin waste should be collected and disposed of as hazardous chemical waste according to institutional and local regulations. The precipitation of tin byproducts with KF during workup is an effective way to convert them into a more easily handled solid form.

Conclusion

Ethyltriphenyltin is a valuable and effective reagent for the transfer of phenyl groups in Stille cross-coupling reactions. Its utility is grounded in the predictable migratory aptitude of the phenyl group over the ethyl group, allowing for selective C-C bond formation. By following the detailed protocols and considering the optimization parameters outlined in this application note, researchers can confidently and safely employ **ethyltriphenyltin** to synthesize a wide range of phenylated compounds, contributing to advancements in drug discovery and materials science.

References

- Stille, J. K. (1986). The Palladium-Catalyzed Cross-Coupling Reactions of Organotin Reagents with Organic Electrophiles. *Angewandte Chemie International Edition in English*, 25(6), 508-524. Available at: [[Link](#)]
- Farina, V., Krishnamurthy, V., & Scott, W. J. (1997). The Stille Reaction. *Organic Reactions*, 50, 1-652. Available at: [[Link](#)]
- Espinet, P., & Echavarren, A. M. (2004). The Mechanisms of the Stille Reaction. *Angewandte Chemie International Edition*, 43(36), 4704-4734. Available at: [[Link](#)]
- NROChemistry. (n.d.). Stille Coupling. Retrieved from [[Link](#)]

Need Custom Synthesis?

BenchChem offers custom synthesis for rare earth carbides and specific isotopic labeling.

Email: info@benchchem.com or [Request Quote Online](#).

Sources

- 1. Advancing total synthesis through the Stille cross-coupling: recent innovations and case studies - PMC [[pmc.ncbi.nlm.nih.gov](https://pubmed.ncbi.nlm.nih.gov/)]
- 2. Stille reaction - Wikipedia [en.wikipedia.org]
- 3. chem.libretexts.org [chem.libretexts.org]
- 4. uwindsor.ca [uwindsor.ca]
- To cite this document: BenchChem. [Application Notes and Protocols: Ethyltriphenyltin in Cross-Coupling Reactions]. BenchChem, [2026]. [Online PDF]. Available at: [<https://www.benchchem.com/product/b1607041/docs#application-notes-and-protocols-ethyltriphenyltin-in-cross-coupling-reactions>]

Disclaimer & Data Validity:

The information provided in this document is for Research Use Only (RUO) and is strictly not intended for diagnostic or therapeutic procedures. While BenchChem strives to provide accurate protocols, we make no warranties, express or implied, regarding the fitness of this product for every specific experimental setup.

Technical Support: The protocols provided are for reference purposes. Unsure if this reagent suits your experiment?

Need Industrial/Bulk Grade? [Request Custom Synthesis Quote](#)

BenchChem

Our mission is to be the trusted global source of essential and advanced chemicals, empowering scientists and researchers to drive progress in science and industry.

Contact

Address: 3281 E Guasti Rd
Ontario, CA 91761, United States
Phone: (601) 213-4426
Email: info@benchchem.com

[Contact our Ph.D. Support Team for a compatibility check](#)