

The Molecular Architecture of alpha-D-Talopyranose: A Technical Guide

Author: BenchChem Technical Support Team. **Date:** April 2026

Compound of Interest

Compound Name: *alpha-D-Talopyranose*

CAS No.: 7282-81-7

Cat. No.: B1606791

[Get Quote](#)

For Researchers, Scientists, and Drug Development Professionals

This guide provides a detailed examination of the structural and physicochemical properties of **alpha-D-Talopyranose**, a C-2 epimer of D-galactose and a C-4 epimer of D-mannose. As a rare aldohexose, understanding its precise molecular structure is crucial for applications in glycobiology, medicinal chemistry, and drug discovery, where stereochemical nuances dictate biological activity.

Physicochemical and Computed Properties

Alpha-D-Talopyranose is a monosaccharide characterized by the molecular formula $C_6H_{12}O_6$. [1][2][3] Its properties have been defined through both experimental and computational methods, which are summarized below.

Property	Value	Reference(s)
Identifier Information		
IUPAC Name	(2S,3S,4S,5R,6R)-6-(hydroxymethyl)oxane-2,3,4,5-tetrol	[1]
CAS Number	7282-81-7	[2]
Molecular Formula	C ₆ H ₁₂ O ₆	[1][2][3]
Molecular Weight	180.158 g/mol	[2]
Exact Mass	180.06338810 Da	[2]
Computed Properties		
pKa	12.12 ± 0.70	[3]
XLogP3	-2.6	[2]
Hydrogen Bond Donor Count	5	[3]
Hydrogen Bond Acceptor Count	6	[3]
Rotatable Bond Count	1	[2]
Topological Polar Surface Area	110 Å ²	[3]
Complexity	151	[2]
Density	1.732 ± 0.06 g/cm ³ (Predicted)	[2]
Boiling Point	410.8 ± 45.0 °C at 760 mmHg (Predicted)	[2]

Molecular Structure and Conformation

The structure of **alpha-D-Talopyranose** is defined by its six-membered pyranose ring and the specific stereochemical arrangement of its hydroxyl (-OH) and hydroxymethyl (-CH₂OH) substituents.

Haworth Projection

The Haworth projection provides a two-dimensional representation of the cyclic pyranose structure. For D-sugars, the $-\text{CH}_2\text{OH}$ group at the C5 position is oriented above the plane of the ring. In **alpha-D-Talopyranose**, the anomeric hydroxyl group at C1 is positioned on the opposite side of the ring from the C5 substituent (i.e., pointing down). The orientations of the remaining hydroxyl groups are as follows:

- C1 (Anomeric Carbon): The alpha (α) configuration places the hydroxyl group in the axial position, pointing downwards in the Haworth projection.
- C2: The hydroxyl group is oriented upwards.
- C3: The hydroxyl group is oriented downwards.
- C4: The hydroxyl group is oriented upwards.
- C5: The hydroxymethyl ($-\text{CH}_2\text{OH}$) group is oriented upwards, characteristic of a D-sugar.

Chair Conformation

The six-membered pyranose ring predominantly adopts a low-energy chair conformation to minimize steric and torsional strain. For most D-aldohexopyranoses, the ${}^4\text{C}_1$ conformation (where C4 is above and C1 is below the plane of the ring) is the most stable. In the ${}^4\text{C}_1$ chair conformation of **alpha-D-Talopyranose**, the substituents occupy the following positions:

- C1: $-\text{OH}$ group is axial.
- C2: $-\text{OH}$ group is axial.
- C3: $-\text{OH}$ group is equatorial.
- C4: $-\text{OH}$ group is axial.
- C5: $-\text{CH}_2\text{OH}$ group is equatorial.

This conformation is notable for having three axial hydroxyl groups at positions C1, C2, and C4. This arrangement leads to significant 1,3-diaxial interactions, rendering **alpha-D-**

Talopyranose less stable than other aldohexoses like D-glucose, where all non-hydrogen substituents can occupy equatorial positions in the beta anomer. Studies on halogenated D-talose analogues confirm that they adopt a standard 4C_1 -like conformation in both solution and the solid state.[4]

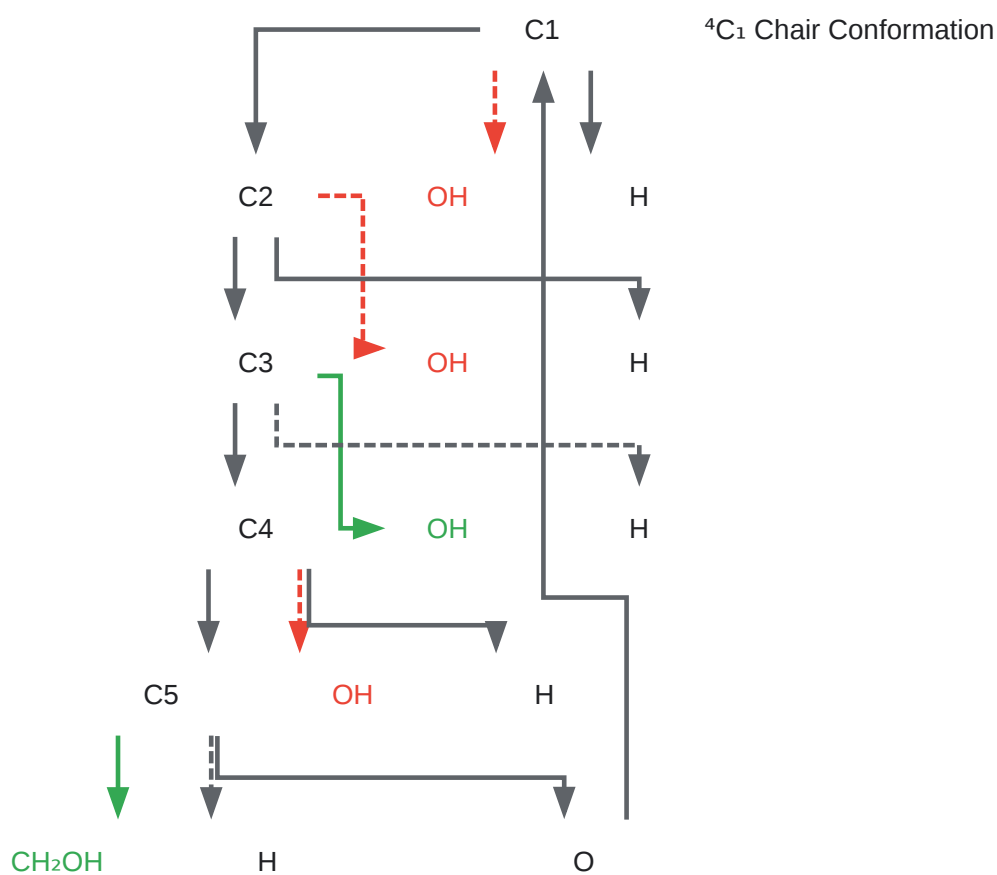

[Click to download full resolution via product page](#)

Caption: 4C_1 chair conformation of **alpha-D-Talopyranose**.

Experimental Protocols

The synthesis and structural characterization of **alpha-D-Talopyranose** and its derivatives are critical for their study and application. Below are summaries of relevant experimental methodologies.

Example Synthetic Protocol: Conversion of D-Galactose to D-Talose

D-talose, being a rare sugar, is often synthesized from more abundant monosaccharides. One established method involves the epimerization of D-galactose at the C2 position.[5]

Logical Workflow for Synthesis:



[Click to download full resolution via product page](#)

Caption: Generalized workflow for the synthesis of D-Talose from D-Galactose.

Detailed Methodology Summary:

- **Protection:** D-galactose is fully acetylated to protect all hydroxyl groups, yielding β -D-galactose pentaacetate.
- **Key Inversion Step:** The equatorial 2-OH group of the protected galactose derivative is inverted to the axial position via an SN2 reaction. This is the key step that transforms the galacto- configuration to the talo- configuration at C2.
- **Deprotection:** The protecting groups (e.g., acetates) are removed under basic conditions (e.g., using sodium methoxide in methanol) to yield D-talose.
- **Purification:** The final product is purified using techniques such as column chromatography or crystallization.

Structural Characterization by NMR Spectroscopy

Nuclear Magnetic Resonance (NMR) spectroscopy is the primary analytical method for unambiguously determining the structure and conformation of carbohydrates in solution.[6][7]

Experimental Procedure Outline:

- **Sample Preparation:** A sample of **alpha-D-Talopyranose** (typically 1-10 mg) is dissolved in a deuterated solvent, most commonly deuterium oxide (D₂O), in a standard 5 mm NMR tube. A chemical shift reference standard may be added.
- **Data Acquisition:** A suite of NMR experiments is performed on a high-field NMR spectrometer (e.g., 400 MHz or higher).
 - **1D ¹H NMR:** This experiment provides information on the chemical shift and coupling constants of all hydrogen atoms. The anomeric proton (H1) of **alpha-D-Talopyranose** typically resonates at a distinct downfield chemical shift. The small coupling constant (³J(H1,H2)) is indicative of the axial-equatorial relationship between H1 and H2, confirming the alpha anomeric configuration.
 - **1D ¹³C NMR:** This experiment identifies the chemical shifts of the six carbon atoms in the molecule.
 - **2D COSY (Correlation Spectroscopy):** This experiment reveals scalar couplings between protons, allowing for the tracing of the proton connectivity network from H1 through H2, H3, H4, to H5 and the H6 protons of the hydroxymethyl group.[7]
 - **2D HSQC/HMQC (Heteronuclear Single Quantum Coherence):** This experiment correlates each proton with its directly attached carbon atom, enabling the unambiguous assignment of the ¹³C spectrum.[7]
 - **2D HMBC (Heteronuclear Multiple Bond Correlation):** This experiment shows correlations between protons and carbons over two to three bonds, helping to confirm the overall structure and assignments.
- **Data Analysis:** The acquired spectra are processed (Fourier transformation, phasing, and baseline correction). The chemical shifts, coupling constants, and cross-peaks from the 2D

spectra are analyzed to assign all signals and confirm the pyranose ring form, the alpha anomeric configuration, and the relative stereochemistry of the substituents. The magnitudes of the vicinal proton-proton coupling constants ($^3J_{HH}$) are particularly useful for determining the dihedral angles between protons and thus confirming the chair conformation and the axial/equatorial positions of the substituents.[8]

Need Custom Synthesis?

BenchChem offers custom synthesis for rare earth carbides and specific isotopic labeling.

Email: info@benchchem.com or [Request Quote Online](#).

References

- [1. alpha-D-talopyranose | C6H12O6 | CID 81696 - PubChem \[pubchem.ncbi.nlm.nih.gov\]](#)
- [2. alpha-D-Talopyranose | lookchem \[lookchem.com\]](#)
- [3. Page loading... \[guidechem.com\]](#)
- [4. researchgate.net \[researchgate.net\]](#)
- [5. researchgate.net \[researchgate.net\]](#)
- [6. Obtaining Pure 1H NMR Spectra of Individual Pyranose and Furanose Anomers of Reducing Deoxyfluorinated Sugars - PMC \[pmc.ncbi.nlm.nih.gov\]](#)
- [7. iosrjournals.org \[iosrjournals.org\]](#)
- [8. A guide to the identification of metabolites in NMR-based metabonomics/metabolomics experiments - PMC \[pmc.ncbi.nlm.nih.gov\]](#)
- To cite this document: BenchChem. [The Molecular Architecture of alpha-D-Talopyranose: A Technical Guide]. BenchChem, [2026]. [Online PDF]. Available at: [\[https://www.benchchem.com/product/b1606791/docs#the-molecular-architecture-of-alpha-d-talopyranose-a-technical-guide\]](https://www.benchchem.com/product/b1606791/docs#the-molecular-architecture-of-alpha-d-talopyranose-a-technical-guide)

Disclaimer & Data Validity:

The information provided in this document is for Research Use Only (RUO) and is strictly not intended for diagnostic or therapeutic procedures. While BenchChem strives to provide

accurate protocols, we make no warranties, express or implied, regarding the fitness of this product for every specific experimental setup.

Technical Support: The protocols provided are for reference purposes. Unsure if this reagent suits your experiment?

Need Industrial/Bulk Grade? [Request Custom Synthesis Quote](#)

BenchChem

Our mission is to be the trusted global source of essential and advanced chemicals, empowering scientists and researchers to drive progress in science and industry.

Contact

Address: 3281 E Guasti Rd

Ontario, CA 91761, United States

Phone: (601) 213-4426

Email: info@benchchem.com

[Contact our Ph.D. Support Team for a compatibility check](#)