

Technical Support Center: Enhancing Enantioselectivity in Spirohydantoin Synthesis

Author: BenchChem Technical Support Team. **Date:** May 2026

Compound of Interest

Compound Name:	1-Methyl-1,3-diazaspiro[4.5]decane-2,4-dione
CAS No.:	878-46-6
Cat. No.:	B1606922

[Get Quote](#)

Welcome to the technical support center dedicated to the stereoselective synthesis of spirohydantoins. This guide is designed for researchers, scientists, and professionals in drug development who are navigating the complexities of creating these stereochemically rich scaffolds. Spirohydantoins are a privileged class of compounds, frequently appearing in biologically active molecules and pharmaceuticals.^[1] Achieving high enantioselectivity in their synthesis is often a critical yet challenging step in the development of novel therapeutics.

This document provides in-depth troubleshooting guides and frequently asked questions (FAQs) to address common issues encountered during experimental work. The advice herein is grounded in established chemical principles and supported by peer-reviewed literature to ensure you can overcome synthetic hurdles with confidence.

Troubleshooting Guide: Common Issues in Enantioselective Spirohydantoin Synthesis

This section addresses specific problems you may encounter during your experiments, offering a systematic approach to diagnosis and resolution.

Issue 1: Low or Inconsistent Enantiomeric Excess (ee)

This is one of the most frequent challenges in asymmetric catalysis. Below is a workflow to diagnose and resolve suboptimal enantioselectivity.

Q: My reaction yields the desired spirohydantoin, but the enantiomeric excess is low and varies between runs. What should I investigate?

A: Low and irreproducible enantioselectivity can stem from multiple factors, ranging from the purity of your reagents to the fundamental reaction parameters. A systematic approach is crucial for effective troubleshooting.

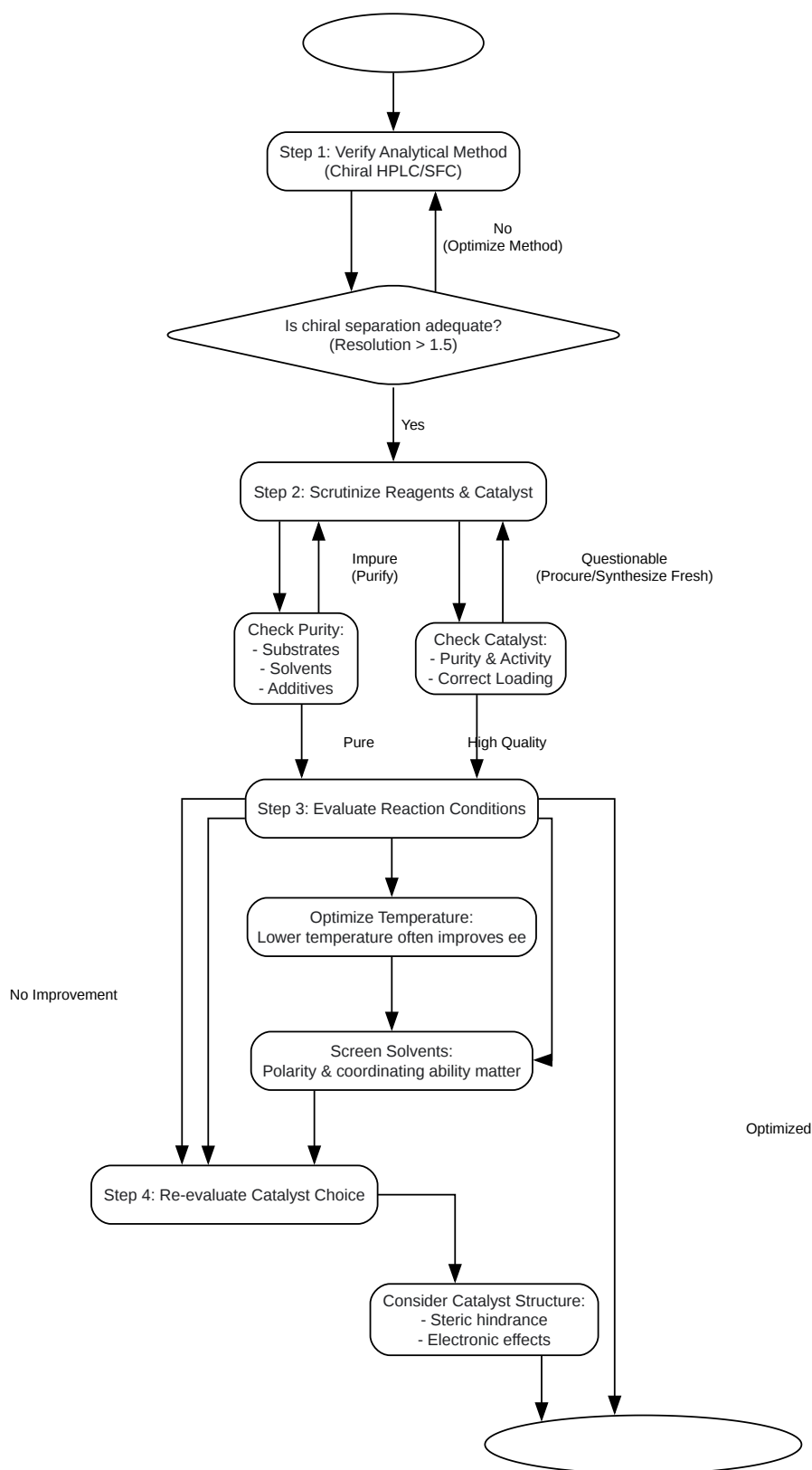

[Click to download full resolution via product page](#)

Caption: Troubleshooting workflow for low enantiomeric excess.

Detailed Breakdown of Troubleshooting Steps:

- **Verify Your Analytical Method:** Before optimizing the reaction, ensure your method for determining ee (typically chiral HPLC or SFC) is accurate and robust. Poor resolution (<1.5) between enantiomer peaks can lead to inaccurate integration and misleading ee values.
- **Scrutinize Reagents and Catalyst:**
 - **Substrate Purity:** Trace impurities in your starting materials can act as catalyst poisons or inhibitors. For instance, residual acids or bases from a previous step can neutralize your catalyst. It is crucial to use highly purified substrates.
 - **Solvent Quality:** The presence of water or other coordinating impurities in the solvent can significantly impact the catalyst's performance by competing for binding sites. Always use anhydrous, and if necessary, degassed solvents.
 - **Catalyst Integrity:** Ensure your catalyst is pure and has not degraded during storage. For sensitive organocatalysts like chiral phosphoric acids, it is advisable to store them under an inert atmosphere and away from light.^[2] Catalyst loading is also critical; sometimes, higher loadings can lead to the formation of less selective dimeric species.
- **Evaluate Reaction Conditions:**
 - **Temperature:** Asymmetric reactions are often highly sensitive to temperature. In many cases, lowering the reaction temperature can enhance enantioselectivity by favoring the transition state that leads to the major enantiomer, as it will have a lower activation energy.
 - **Solvent:** The solvent plays a critical role in the catalytic cycle. Its polarity and ability to solvate intermediates can influence the stability of the transition states. A screening of different solvents is often necessary to find the optimal balance between reactivity and selectivity.
 - **Concentration:** Reactant concentration can influence the reaction order and the formation of catalyst aggregates. It is recommended to investigate the effect of concentration on enantioselectivity.

Issue 2: Poor Yield or Stalled Reaction

Q: My reaction is not proceeding to completion, or the yield of the spirohydantoin is very low. What could be the problem?

A: Poor reactivity can be due to catalyst deactivation, suboptimal reaction conditions, or inherent substrate limitations.

- **Catalyst Deactivation:** As mentioned above, impurities in the reagents or solvent can deactivate the catalyst. Ensure all components of the reaction are pure and the reaction is performed under an inert atmosphere if the catalyst is sensitive to air or moisture.
- **Insufficient Catalyst Loading:** While high catalyst loading can sometimes decrease ee, too low a loading may result in a stalled reaction. It is important to find the optimal catalyst concentration.
- **Temperature:** While lower temperatures often favor enantioselectivity, they also decrease the reaction rate. A balance must be struck. If the reaction is too slow at a low temperature, a systematic increase in temperature should be explored, while monitoring the effect on both yield and ee.
- **Substrate Reactivity:** The electronic and steric properties of the substrates can significantly affect their reactivity. For example, in a [3+2] cycloaddition to form a spiropyrrolidinyl-hydantoin, highly sterically hindered dipolarophiles may react sluggishly.^[3] In such cases, a more active catalyst or more forcing reaction conditions may be necessary.

Frequently Asked Questions (FAQs)

Q1: How do I choose the right chiral catalyst for my spirohydantoin synthesis?

A1: The choice of catalyst is highly dependent on the specific reaction used to construct the spirocyclic framework. The main classes of catalysts used in asymmetric synthesis are:

- **Organocatalysts:** These are metal-free small organic molecules. Chiral phosphoric acids (CPAs) have shown great promise for reactions involving imines or carbonyls, activating them through hydrogen bonding.^{[1][4]} Chiral amines and their derivatives (e.g., squaramides, thioureas) are effective in Michael additions and aldol reactions.^[5]

- **Transition Metal Catalysts:** These consist of a metal center (e.g., Cu, Ag, Ir) coordinated to a chiral ligand.[6] They are particularly effective in 1,3-dipolar cycloadditions and other reactions involving the formation of carbon-carbon bonds.[3]
- **Phase-Transfer Catalysts (PTCs):** Chiral quaternary ammonium salts, often derived from Cinchona alkaloids, are used in reactions involving two immiscible phases.[7] They are particularly useful for the alkylation of pronucleophiles.

The best approach is to start with a catalyst class that has been reported for a similar transformation and then screen a small library of catalysts within that class to identify the optimal one for your specific substrates.

Q2: What is the role of the hydantoin N-substituents in controlling stereoselectivity?

A2: The substituents on the nitrogen atoms of the hydantoin ring can have a significant impact on stereoselectivity. They can influence the steric environment around the reacting center and may also participate in non-covalent interactions with the catalyst-substrate complex. For example, a bulky N-substituent can effectively block one face of the molecule, directing the attack of the reagent to the opposite face. It is often beneficial to screen different N-protecting groups or substituents to optimize enantioselectivity.

Q3: How does a chiral phosphoric acid (CPA) catalyst induce enantioselectivity?

A3: Chiral phosphoric acids are a powerful class of Brønsted acid organocatalysts.[4] They possess a well-defined chiral pocket created by bulky substituents on a binaphthyl or spirobiindane backbone.[4] The catalyst activates an electrophile (e.g., an imine or a glyoxal) by protonating it, while simultaneously organizing the nucleophile through hydrogen bonding with the phosphate anion. This dual activation within the chiral environment forces the nucleophile to approach the electrophile from a specific face, leading to the preferential formation of one enantiomer.[1]

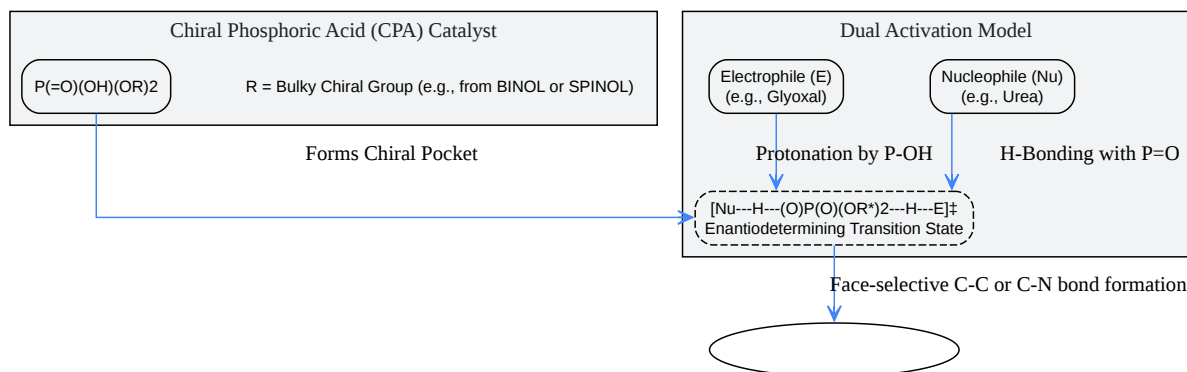

[Click to download full resolution via product page](#)

Need Custom Synthesis?

BenchChem offers custom synthesis for rare earth carbides and specific isotopic labeling.

Email: info@benchchem.com or [Request Quote Online](#).

Sources

- 1. Enantioselective synthesis of hydantoins by chiral acid-catalysed condensation of glyoxals and ureas - PMC [pubmed.ncbi.nlm.nih.gov]
- 2. lac.dicp.ac.cn [lac.dicp.ac.cn]
- 3. Catalytic asymmetric construction of spiropyrrolidines via 1,3-dipolar cycloaddition of azomethine ylides - PubMed [pubmed.ncbi.nlm.nih.gov]
- 4. e3s-conferences.org [e3s-conferences.org]
- 5. Organocatalytic Enantioselective Vinylogous Michael-Aldol Cascade for the Synthesis of Spirocyclic Compounds - PubMed [pubmed.ncbi.nlm.nih.gov]
- 6. Switching Diastereoselectivity in Catalytic Enantioselective (3+2) Cycloadditions of Azomethine Ylides Promoted by Metal Salts and Privileged Segphos-Derived Ligands [organic-chemistry.org]

- 7. BJOC - Facile synthesis of hydantoin/1,2,4-oxadiazoline spiro-compounds via 1,3-dipolar cycloaddition of nitrile oxides to 5-iminohydantoins [beilstein-journals.org]
- To cite this document: BenchChem. [Technical Support Center: Enhancing Enantioselectivity in Spirohydantoin Synthesis]. BenchChem, [2026]. [Online PDF]. Available at: [<https://www.benchchem.com/product/b1606922/docs#technical-support-center-enhancing-enantioselectivity-in-spirohydantoin-synthesis>]

Disclaimer & Data Validity:

The information provided in this document is for Research Use Only (RUO) and is strictly not intended for diagnostic or therapeutic procedures. While BenchChem strives to provide accurate protocols, we make no warranties, express or implied, regarding the fitness of this product for every specific experimental setup.

Technical Support: The protocols provided are for reference purposes. Unsure if this reagent suits your experiment?

Need Industrial/Bulk Grade? [Request Custom Synthesis Quote](#)

BenchChem

Our mission is to be the trusted global source of essential and advanced chemicals, empowering scientists and researchers to drive progress in science and industry.

Contact

Address: 3281 E Guasti Rd
Ontario, CA 91761, United States
Phone: (601) 213-4426
Email: info@benchchem.com

[Contact our Ph.D. Support Team for a compatibility check](#)