

Technical Support Center: Chemical Synthesis of Modified Cap Analogs

Author: BenchChem Technical Support Team. **Date:** April 2026

Compound of Interest

Compound Name: *2'-O-methyladenosine 5'-phosphate*

CAS No.: *24121-00-4*

Cat. No.: *B1606524*

[Get Quote](#)

This technical support center provides troubleshooting guidance and frequently asked questions (FAQs) for researchers, scientists, and drug development professionals engaged in the chemical synthesis of modified cap analogs.

Troubleshooting Guides

This section addresses specific issues that may be encountered during the synthesis, purification, and analysis of modified cap analogs.

Problem 1: Low Yield of the Desired Cap Analog

Possible Causes & Solutions

Possible Cause	Troubleshooting Step	Expected Outcome
Incomplete reaction	Extend the reaction time or increase the temperature according to the specific protocol. Monitor reaction progress using TLC or LC-MS.	Increased conversion of starting materials to the desired product.
Degradation of starting materials or product	Nucleosides and nucleotides can be sensitive to acidic or basic conditions.[1][2] Ensure the pH of the reaction mixture is maintained within the optimal range for the specific compounds. Use high-purity, anhydrous solvents to prevent hydrolysis.	Minimized degradation and increased yield of the target cap analog.
Inefficient coupling reaction	The coupling between the activated and non-activated nucleotide is a critical step.[1][2] Ensure the activating agent (e.g., CDI, ZnCl ₂) is fresh and used in the correct molar ratio. Consider using a different coupling catalyst if yields remain low.	Improved efficiency of the pyrophosphate bond formation, leading to higher product yield.
Suboptimal stoichiometry of reactants	Carefully verify the molar ratios of all reactants, especially the ratio of the cap analog to GTP in co-transcriptional capping reactions.[3]	An optimized ratio will maximize the incorporation of the cap analog while maintaining a reasonable overall transcription yield.

Problem 2: Presence of a Significant Amount of Uncapped RNA or a Low Capping Efficiency

Possible Causes & Solutions

Possible Cause	Troubleshooting Step	Expected Outcome
Competition with GTP	In co-transcriptional capping, GTP competes with the cap analog for initiation of transcription by RNA polymerase.[3] A commonly recommended starting ratio of cap analog to GTP is 4:1.[3][4][5] Increasing this ratio can enhance capping efficiency, but may decrease the overall RNA yield.[3][5][6]	Higher percentage of capped mRNA transcripts.
Suboptimal transcription conditions	Optimize the in vitro transcription (IVT) reaction conditions, including enzyme concentration, temperature, and incubation time. For some cap analogs, specific promoters or initiation sequences (e.g., AG instead of GG for CleanCap® Reagent AG) are required for efficient incorporation.[3][7]	Increased overall yield and improved capping efficiency.
Degradation of the cap analog	Ensure the cap analog is properly stored and handled to avoid degradation. Repeated freeze-thaw cycles should be avoided.	Consistent and reliable capping efficiency in your experiments.

Problem 3: Difficulty in Purifying the Modified Cap Analog

Possible Causes & Solutions

Possible Cause	Troubleshooting Step	Expected Outcome
Co-elution of capped and uncapped species	Capped and uncapped mRNA have very similar physicochemical properties, making their separation challenging.[8][9] Anion-exchange chromatography (e.g., using DEAE Sepharose) or reversed-phase high-performance liquid chromatography (RP-HPLC) are commonly used for purification.[2][8] For RP-HPLC, optimizing the gradient of the mobile phase is crucial for achieving good separation.	Successful separation of the capped mRNA from uncapped species and other reaction components.
Presence of side products from the synthesis	Analyze the crude reaction mixture by LC-MS to identify major impurities. Modify the purification protocol (e.g., adjust the pH or the salt concentration of the elution buffer in ion-exchange chromatography) to improve the separation of the desired product from these impurities.	Isolation of the modified cap analog with high purity.
Formation of double-stranded RNA (dsRNA) byproducts	During in vitro transcription, dsRNA byproducts can form, which can be immunogenic.[8][10] RP-HPLC is an effective method for removing dsRNA impurities.[8][10]	A purified mRNA sample with reduced immunogenicity and improved translational performance.

Frequently Asked Questions (FAQs)

Q1: What is "reverse incorporation" of a cap analog and how can it be prevented?

A1: Standard cap analogs like m⁷GpppG have a free 3'-OH group on both the 7-methylguanosine (m⁷G) and the guanosine (G) moieties. During in vitro transcription, RNA polymerase can initiate transcription from either of these 3'-OH groups. This leads to the incorporation of the cap analog in both the correct ("forward") orientation (m⁷GpppG-RNA) and the incorrect ("reverse") orientation (Gppp(m⁷G)-RNA).[11] Transcripts with a reverse-oriented cap are not translated efficiently, which reduces the overall protein yield from the synthetic mRNA.[11][12]

To overcome this problem, Anti-Reverse Cap Analogs (ARCAs) were developed.[2][4][12][13] ARCAs have a modification, typically a methyl group, at the 3'-OH position of the m⁷G moiety. This modification blocks the elongation from the incorrect end, ensuring that the cap analog is incorporated exclusively in the correct forward orientation.[2][4][13]

Q2: What are the main challenges in the chemical synthesis of modified cap analogs?

A2: The chemical synthesis of modified cap analogs is challenging due to several factors:

- **Multiple Functional Groups:** Nucleosides and nucleotides have multiple reactive functional groups (hydroxyl, amino groups) that require a careful strategy of protection and deprotection to achieve the desired synthesis.[1][2]
- **Sensitivity to pH:** The nucleoside/nucleotide structures can be unstable under acidic or basic conditions, which can lead to cleavage of glycosidic bonds or other side reactions.[1][2]
- **Formation of the Pyrophosphate Bridge:** The key step of forming the 5'-5' triphosphate linkage between the two nucleosides can be difficult and often requires specialized coupling reagents and anhydrous conditions.[14]
- **Purification:** The high polarity and similar chemical properties of the desired cap analog and various side products (e.g., unreacted starting materials, monophosphates, diphosphates) make purification challenging, often requiring techniques like anion-exchange chromatography or RP-HPLC.[2]

Q3: How can I analyze the purity and capping efficiency of my synthesized mRNA?

A3: Several analytical techniques can be used to assess the quality of your synthesized capped mRNA:

- Denaturing Polyacrylamide Gel Electrophoresis (PAGE): This method can be used to separate capped from uncapped mRNA, as the cap structure can slightly alter the electrophoretic mobility.[\[15\]](#)
- High-Performance Liquid Chromatography (HPLC): Anion-exchange HPLC can separate different reaction components, including the cap analog, NTPs, and the mRNA product.[\[11\]](#) Ion-pair reversed-phase (IP-RP) HPLC is particularly useful for separating capped and uncapped oligonucleotides and for assessing overall purity.[\[13\]](#)[\[16\]](#)
- Liquid Chromatography-Mass Spectrometry (LC-MS): LC-MS is a powerful technique for confirming the identity and purity of the cap analog and for determining the capping efficiency of the mRNA.[\[13\]](#)[\[16\]](#)[\[17\]](#)[\[18\]](#)[\[19\]](#) By digesting the mRNA with specific nucleases (like RNase T1 or RNase H), the 5' end fragments (both capped and uncapped) can be generated and then analyzed by LC-MS to quantify the capping efficiency.[\[13\]](#)[\[17\]](#)[\[18\]](#)

Q4: What is the difference between Cap 0, Cap 1, and Cap 2 structures?

A4: The different cap structures refer to the extent of methylation on the first and second nucleotides of the mRNA transcript, following the 7-methylguanosine.

- Cap 0: This is the basic cap structure (m^7GpppN), where the first nucleotide (N) is not methylated at the 2'-hydroxyl position of the ribose.
- Cap 1: In higher eukaryotes, the first nucleotide is typically methylated at the 2'-OH position ($m^7GpppNm$). This modification is important for distinguishing self-RNA from non-self-RNA, thereby reducing the innate immune response.[\[3\]](#)
- Cap 2: In some cases, the second nucleotide is also methylated at the 2'-OH position.

Trinucleotide and tetranucleotide cap analogs have been developed to co-transcriptionally generate Cap 1 or Cap 2 structures, which can enhance mRNA stability and translational efficiency.[\[12\]](#)

Quantitative Data Summary

The following tables summarize quantitative data on the capping efficiency, translation efficiency, and stability of various modified cap analogs.

Table 1: Capping Efficiency of Different Cap Analogs

Cap Analog	Capping Efficiency (%)	Notes	Reference(s)
m ⁷ GpppG (Standard)	~50-80%	Efficiency is dependent on the cap:GTP ratio.	[10]
ARCA (Anti-Reverse Cap Analog)	~70-80%	Eliminates reverse incorporation, but high concentrations can reduce overall yield.	[3][4][20]
CleanCap® Reagent AG	>95%	A trinucleotide analog that allows for high capping efficiency without reducing GTP concentration.	[3][7]
Phosphorothioate-modified ARCA	Varies	Can be efficiently incorporated.	[1]
Hydrophobic-tagged "PureCap"	60% (initial)	Can be optimized to higher efficiencies.	[21]

Table 2: Relative Translation Efficiency of mRNAs with Modified Cap Analogs

Cap Analog	Relative Translation Efficiency (compared to m ⁷ GpppG)	Cell/System	Reference(s)
ARCA (m ₂ ⁷ , ² ¹⁰ GpppG)	1.59	Rabbit Reticulocyte Lysate	[22]
b ⁷ m ² Gp ₄ G	2.55	In vitro	[23]
m ⁷ Gp ₄ m ⁷ G	3.1	In vitro	[23]
β-phosphorothioate modified ARCA (D2)	~2.3-fold higher	Mammalian cells	[2]
Deoxyadenosine-modified "PureCap"	3.2	Not specified	[21]

Table 3: Stability of mRNAs with Modified Cap Analogs

Cap Analog	mRNA Half-life (t _{1/2})	Notes	Reference(s)
m ⁷ Gp ₃ G (Standard)	86 ± 1 min	Luciferase mRNA in mammalian cells.	[1]
ARCA (m ₂ ⁷ , ² ¹⁰ Gp ₃ G)	155 ± 9 min	Luciferase mRNA in mammalian cells.	[1]
β-phosphorothioate ARCA (D2)	257 ± 4 min	Luciferase mRNA in mammalian cells; increased resistance to decapping enzymes.	[1]
Phosphorothioate caps (general)	Increased stability	Protects oligonucleotides from nucleolytic degradation.	[24]

Experimental Protocols

Protocol 1: General Chemical Synthesis of a Dinucleotide Cap Analog (e.g., ARCA)

This protocol provides a general overview of the chemical synthesis of an ARCA-type cap analog. Specific reaction conditions, protecting groups, and purification methods will vary depending on the specific modifications.

Materials:

- Protected 7-methylguanosine derivative
- Protected guanosine derivative
- Phosphorylating agent (e.g., POCl_3)
- Coupling agent (e.g., ZnCl_2 , CDI)
- Anhydrous solvents (e.g., DMF, DMSO)
- Purification resins (e.g., DEAE-Sephadex or Sepharose)
- Triethylammonium bicarbonate (TEAB) buffer

Methodology:

- Phosphorylation: One of the protected nucleosides is phosphorylated to obtain the corresponding 5'-monophosphate or 5'-diphosphate. This is often achieved using a phosphorylating agent like phosphoryl chloride.
- Activation: One of the phosphorylated nucleosides is activated to facilitate the coupling reaction. A common method is the formation of a phosphorimidazolidine derivative using 1,1'-carbonyldiimidazole (CDI).^[20]
- Coupling: The activated nucleotide is reacted with the other phosphorylated nucleoside in the presence of a catalyst, such as zinc chloride (ZnCl_2), in an anhydrous solvent like DMF.^[2]
^[20] This reaction forms the 5'-5' triphosphate bridge.

- Deprotection: All protecting groups on the sugar and base moieties are removed under appropriate conditions (e.g., treatment with ammonia or other specific reagents).
- Purification: The crude reaction mixture is purified using anion-exchange chromatography.[2] The components are eluted using a gradient of a buffer like triethylammonium bicarbonate (TEAB). The order of elution is typically monophosphate, then diphosphate, and finally the desired triphosphate cap analog.[2]
- Analysis: The purity and identity of the final product are confirmed by HPLC and mass spectrometry.

Protocol 2: Purification of Capped mRNA using Reversed-Phase HPLC (RP-HPLC)

Materials:

- Crude in vitro transcription reaction mixture
- HPLC system with a suitable C18 column
- Mobile Phase A: Aqueous buffer (e.g., triethylammonium acetate or hexafluoroisopropanol-based)
- Mobile Phase B: Acetonitrile or methanol
- Nuclease-free water

Methodology:

- Sample Preparation: The crude IVT reaction mixture may need to be clarified by centrifugation to remove any precipitated salts or proteins.
- HPLC Setup: Equilibrate the RP-HPLC column with the starting mobile phase conditions (a low percentage of Mobile Phase B).
- Injection and Separation: Inject the sample onto the column. The separation is achieved by applying a linear gradient of increasing concentration of the organic mobile phase (Mobile Phase B). The hydrophobic nature of the cap (especially with hydrophobic tags) or the

overall mRNA structure allows for separation from uncapped RNA and other reaction components.[8]

- **Fraction Collection:** Collect the fractions corresponding to the peak of the capped mRNA, as determined by UV absorbance at 260 nm.
- **Desalting and Recovery:** The collected fractions are typically desalted (e.g., by ethanol precipitation) to remove the ion-pairing reagents from the mobile phase.
- **Analysis:** The purity of the collected mRNA should be assessed by analytical HPLC, gel electrophoresis, and/or LC-MS.

Visualizations

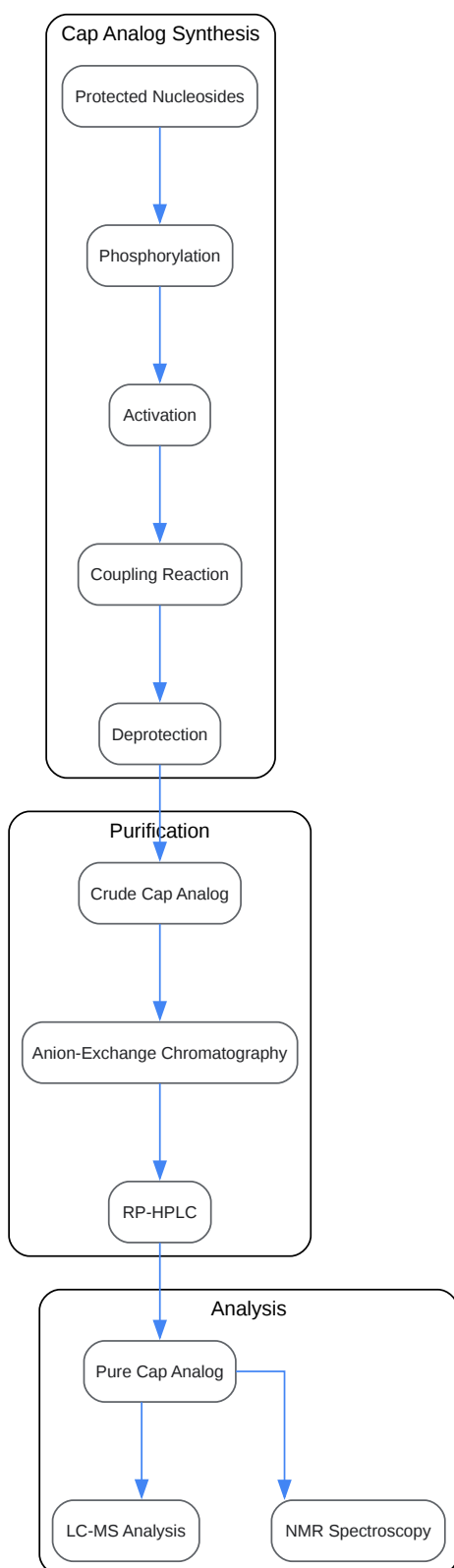

[Click to download full resolution via product page](#)

Caption: Workflow for the chemical synthesis, purification, and analysis of a modified cap analog.

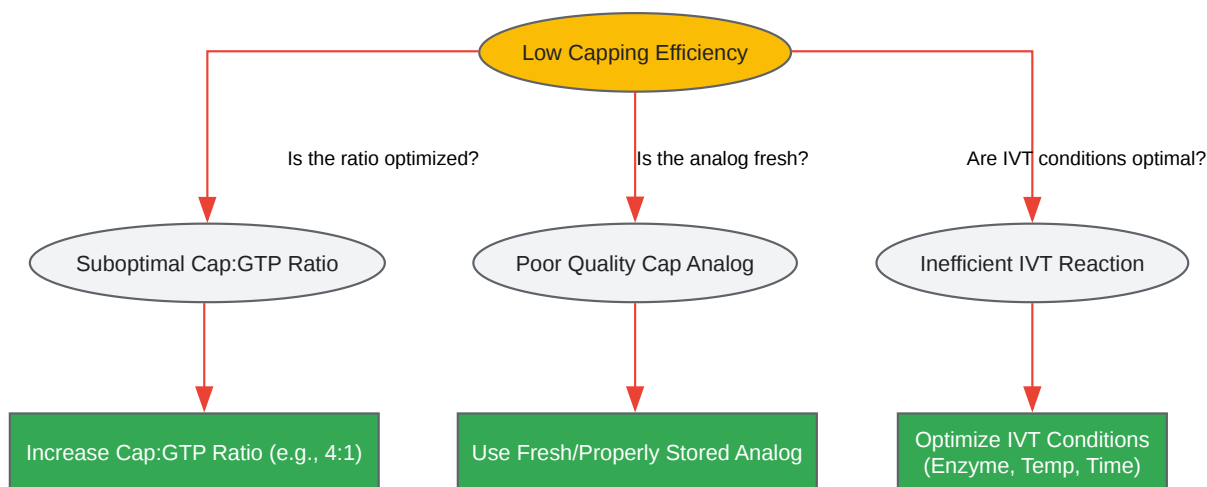

[Click to download full resolution via product page](#)

Caption: Troubleshooting logic for addressing low co-transcriptional capping efficiency.

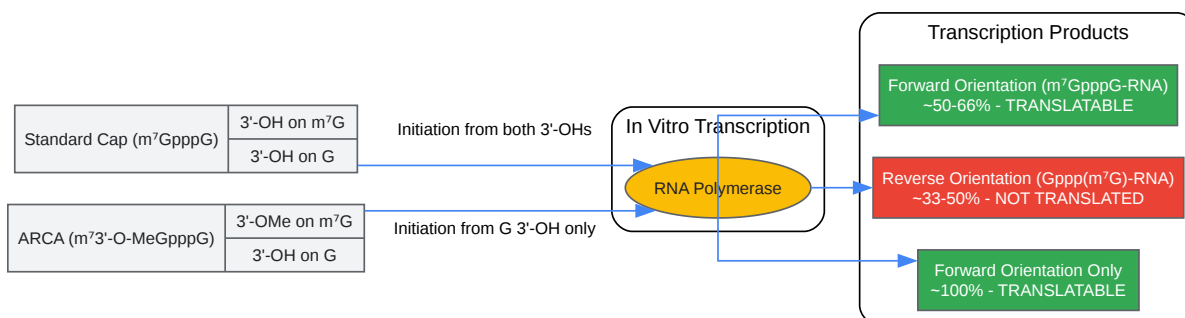

[Click to download full resolution via product page](#)

Need Custom Synthesis?

BenchChem offers custom synthesis for rare earth carbides and specific isotopic labeling.

Email: info@benchchem.com or [Request Quote Online](#).

References

- 1. Phosphorothioate cap analogs stabilize mRNA and increase translational efficiency in mammalian cells - PMC [[pmc.ncbi.nlm.nih.gov](https://pubmed.ncbi.nlm.nih.gov/)]
- 2. Recent Advances in Modified Cap Analogs: Synthesis, Biochemical Properties, and mRNA Based Vaccines - PMC [[pmc.ncbi.nlm.nih.gov](https://pubmed.ncbi.nlm.nih.gov/)]
- 3. Methods of IVT mRNA capping - Behind the Bench [[thermofisher.com](https://www.thermofisher.com)]
- 4. [bocsci.com](https://www.bocsci.com) [[bocsci.com](https://www.bocsci.com)]
- 5. [neb.com](https://www.neb.com) [[neb.com](https://www.neb.com)]
- 6. An engineered T7 RNA polymerase for efficient co-transcriptional capping with reduced dsRNA byproducts in mRNA synthesis - Faraday Discussions (RSC Publishing) DOI:10.1039/D4FD00023D [pubs.rsc.org]
- 7. [neb.com](https://www.neb.com) [[neb.com](https://www.neb.com)]
- 8. Cap analogs with a hydrophobic photocleavable tag enable facile purification of fully capped mRNA with various cap structures - PMC [[pmc.ncbi.nlm.nih.gov](https://pubmed.ncbi.nlm.nih.gov/)]
- 9. [researchgate.net](https://www.researchgate.net) [[researchgate.net](https://www.researchgate.net)]
- 10. [trilinkbiotech.com](https://www.trilinkbiotech.com) [[trilinkbiotech.com](https://www.trilinkbiotech.com)]
- 11. [researchgate.net](https://www.researchgate.net) [[researchgate.net](https://www.researchgate.net)]
- 12. [benchchem.com](https://www.benchchem.com) [[benchchem.com](https://www.benchchem.com)]
- 13. [researchgate.net](https://www.researchgate.net) [[researchgate.net](https://www.researchgate.net)]
- 14. Synthetic mRNA capping - PMC [[pmc.ncbi.nlm.nih.gov](https://pubmed.ncbi.nlm.nih.gov/)]
- 15. US20210040526A1 - Methods and means for enhancing rna production - Google Patents [patents.google.com]
- 16. Characterisation and analysis of mRNA critical quality attributes using liquid chromatography based methods - PMC [[pmc.ncbi.nlm.nih.gov](https://pubmed.ncbi.nlm.nih.gov/)]
- 17. Liquid Chromatography–Mass Spectrometry-Based Qualitative Profiling of mRNA Therapeutic Reagents Using Stable Isotope-Labeled Standards Followed by the Automatic

[Quantitation Software Ariadne - PMC \[pmc.ncbi.nlm.nih.gov\]](#)

- [18. lcms.cz \[lcms.cz\]](#)
- [19. Quantification of mRNA cap-modifications by means of LC-QqQ-MS - PMC \[pmc.ncbi.nlm.nih.gov\]](#)
- [20. researchgate.net \[researchgate.net\]](#)
- [21. academic.oup.com \[academic.oup.com\]](#)
- [22. Modified ARCA analogs providing enhanced translational properties of capped mRNAs - PMC \[pmc.ncbi.nlm.nih.gov\]](#)
- [23. Novel cap analogs for in vitro synthesis of mRNAs with high translational efficiency - PMC \[pmc.ncbi.nlm.nih.gov\]](#)
- [24. academic.oup.com \[academic.oup.com\]](#)
- [To cite this document: BenchChem. \[Technical Support Center: Chemical Synthesis of Modified Cap Analogs\]. BenchChem, \[2026\]. \[Online PDF\]. Available at: \[https://www.benchchem.com/product/b1606524/docs#technical-support-center-chemical-synthesis-of-modified-cap-analogs\]](#)

Disclaimer & Data Validity:

The information provided in this document is for Research Use Only (RUO) and is strictly not intended for diagnostic or therapeutic procedures. While BenchChem strives to provide accurate protocols, we make no warranties, express or implied, regarding the fitness of this product for every specific experimental setup.

Technical Support: The protocols provided are for reference purposes. Unsure if this reagent suits your experiment?

Need Industrial/Bulk Grade? [Request Custom Synthesis Quote](#)

BenchChem

Our mission is to be the trusted global source of essential and advanced chemicals, empowering scientists and researchers to drive progress in science and industry.

Contact

Address: 3281 E Guasti Rd

Ontario, CA 91761, United States

Phone: (601) 213-4426

Email: info@benchchem.com

[Contact our Ph.D. Support Team for a compatibility check](#)