

# Technical Support Center: Solubility Optimization for N-Methyl-2-naphthamide

**Author:** BenchChem Technical Support Team. **Date:** May 2026

## Compound of Interest

Compound Name: *n-methyl-2-naphthamide*

CAS No.: 3815-22-3

Cat. No.: B1605573

[Get Quote](#)

Ticket ID: #SOL-NM2NA-001 Status: Open Assigned Specialist: Dr. A. Vance, Senior Application Scientist Subject: Overcoming solubility bottlenecks in biological assays and synthetic lithiation.

## Introduction: The "Brick Dust" Challenge

Welcome to the technical support center. You are likely here because **N-methyl-2-naphthamide** (CAS: 3815-22-3) is failing to dissolve in your aqueous media or precipitating during low-temperature lithiation.

This molecule presents a classic "brick dust" profile: a rigid, planar naphthalene core (highly lipophilic) coupled with a polar amide handle. The high melting point (~108–109°C) indicates strong crystal lattice energy that solvents must overcome.

This guide is structured to address the two distinct environments where this molecule fails: Biological Assays (Aqueous/Physiological) and Organic Synthesis (Anhydrous/Cryogenic).

## Module 1: Biological Assay Formulation

## The Problem: The "Ouzo Effect"

When you dilute a concentrated DMSO stock of **N-methyl-2-naphthamide** into aqueous buffer, you likely observe immediate cloudiness. This is the "Ouzo effect"—spontaneous emulsification caused by the rapid displacement of DMSO by water, forcing the hydrophobic naphthalene core to aggregate.

## The Solution: Cyclodextrin Complexation

Simple cosolvent spikes (e.g., 1% DMSO) are often insufficient for this compound at micromolar concentrations. The most robust fix is encapsulating the naphthalene tail in a cyclodextrin cavity.

### Protocol: HP- $\beta$ -CD Solubilization System

Why this works: Hydroxypropyl- $\beta$ -cyclodextrin (HP- $\beta$ -CD) has a hydrophobic interior that hosts the naphthalene ring and a hydrophilic exterior that interacts with the buffer.

Step	Action	Technical Rationale
1	Prepare Stock	Dissolve N-methyl-2-naphthamide in 100% DMSO to 1000x the final assay concentration (e.g., 10 mM).
2	Prepare Vehicle	Prepare a 20% (w/v) HP- $\beta$ -CD solution in your assay buffer (PBS or Media). Vortex until clear.
3	Intermediate Spike	Dilute the DMSO stock 1:10 into the HP- $\beta$ -CD Vehicle (not pure buffer). Vortex immediately. Result: 1 mM compound in 10% DMSO / 18% CD.
4	Final Dilution	Dilute the Intermediate mix 1:100 into the final assay buffer.

Key Metric: This method typically increases aqueous solubility limits by 50–100 fold compared to DMSO/Water alone [1].

## Visual Workflow: Preventing Precipitation

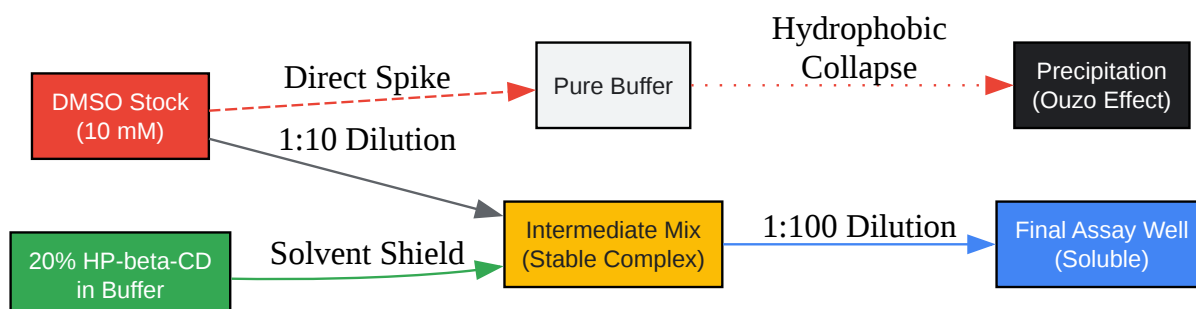

[Click to download full resolution via product page](#)

Figure 1: Strategic dilution workflow. Direct spiking into buffer causes precipitation (black path). Using a Cyclodextrin intermediate creates a soluble inclusion complex (colored path).

## Module 2: Synthetic Optimization (Lithiation)

### The Problem: Cryogenic Solubility

**N-methyl-2-naphthamide** is a common substrate for Directed Ortho Metalation (DoM). However, at  $-78^{\circ}\text{C}$  (dry ice/acetone bath), the starting material often crashes out of THF, halting the reaction or leading to heterogeneous lithiation.

### The Solution: Deaggregation & Solvent Switching

Lithium amides form large aggregates in pure THF. You must break these aggregates to maintain solubility and reactivity.

### Troubleshooting Table: DoM Reaction Conditions

Variable	Recommendation	Mechanism
Solvent	Anhydrous THF (Primary)	Standard etherial solvent with good coordination to Li.
Additive	TMEDA (1.1 - 2.0 equiv)	Critical. Tetramethylethylenediamine (TMEDA) chelates Lithium, breaking oligomers and preventing the "crashing out" of the lithiated intermediate [2].
Base	n-BuLi or s-BuLi	s-BuLi is more reactive but requires strictly lower temperatures.
Temp	-78°C to -40°C	If precipitation occurs at -78°C, slowly warm to -40°C after base addition to redissolve the lithiated species (often more soluble than the neutral amide).

## Advanced Protocol: The "Cannula" Trick

If the starting material is insoluble in THF at -78°C:

- Dissolve the amide in THF at 0°C (or room temp).
- Pre-cool the reaction flask containing the base (n-BuLi/TMEDA) to -78°C.
- Add the warm amide solution dropwise down the side of the cold flask (or via cannula) into the base. The deprotonation (lithiation) is faster than the precipitation rate, generating the soluble lithiated species immediately.

## Module 3: General Solvent Compatibility

Use this reference table to select the correct carrier solvent for your specific application.

Solvent	Solubility Rating	Application Context	Warning
DMSO	High (>50 mM)	Stock solutions, Cryopreservation	High freezing point (19°C). Hygroscopic (absorbs water).
Ethanol	Moderate	HPLC mobile phase	Volatile. May strip plasticizers from labware.
DCM	Very High	Extraction, Chromatography	Toxic. Immiscible with water.
Water	Negligible	Do not use as primary solvent	Requires surfactants or cyclodextrins.
THF	High (at 25°C)	Synthesis (DoM)	Peroxide former. Solubility drops sharply < 0°C.

## Module 4: Logical Troubleshooting (FAQ)

Q: My compound precipitated in the cell culture media even with DMSO. Why? A: This is local supersaturation. When you pipette DMSO stock into media, the interface concentration exceeds solubility instantly.

- Fix: Vortex the media while adding the DMSO stock slowly. Do not add stock to a static well.

Q: Can I use sonication to redissolve the precipitate? A: Only for chemical stocks. Never sonicate protein-containing media or live cells, as this generates heat and cavitation bubbles that denature proteins and lyse cells. If it precipitated in media, discard and restart with the Cyclodextrin protocol.

Q: I see "oiling out" instead of crystals during synthesis. A: This indicates impurities or a solvent mixture where the compound is in a "melt" state.

- Fix: Add a seed crystal of **N-methyl-2-naphthamide** and scratch the glass surface to induce proper crystallization, or switch to a recrystallization solvent system like Toluene/Hexane.

## Decision Logic: Solubility Optimization

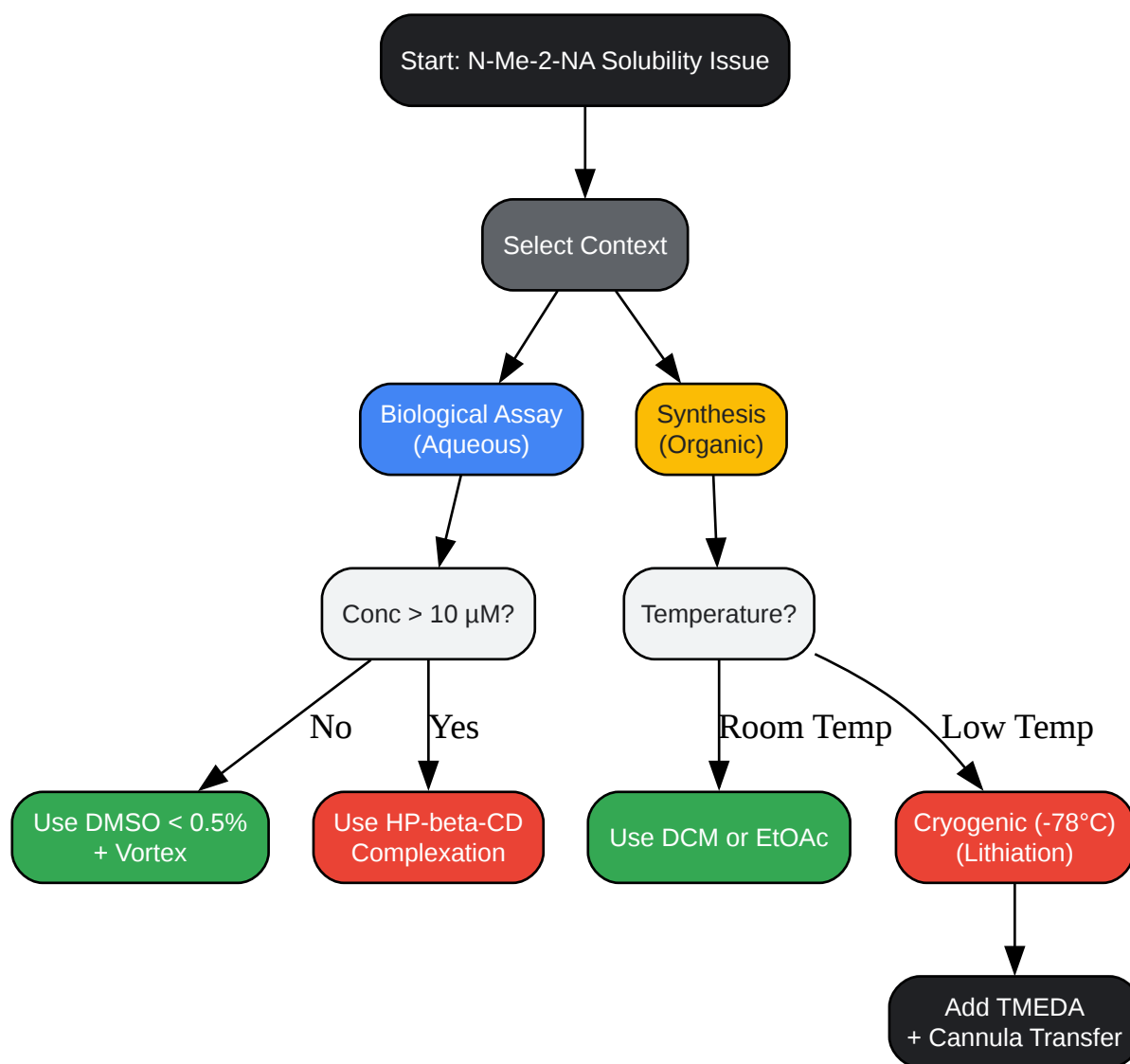

[Click to download full resolution via product page](#)

Figure 2: Decision matrix for selecting the appropriate solubilization strategy based on experimental context.

## References

- Loftsson, T., & Brewster, M. E. (2010). Pharmaceutical applications of cyclodextrins: basic science and product development. *Journal of Pharmacy and Pharmacology*.

- Clayden, J. (2002). Organolithiums: Selectivity for Synthesis. Pergamon. (See Chapter on Directed Ortho Metalation and the role of TMEDA/THF complexes).
- PubChem Database. (n.d.). **N-Methyl-2-naphthamide** (CAS 3815-22-3) Physical Properties.
- Snieckus, V. (1990).[1] Directed ortho metalation.[1][2][3][4] Tertiary amide and O-carbamate directors in synthetic strategies for polysubstituted aromatics. Chemical Reviews.

### Need Custom Synthesis?

BenchChem offers custom synthesis for rare earth carbides and specific isotopic labeling.

Email: [info@benchchem.com](mailto:info@benchchem.com) or [Request Quote Online](#).

## Sources

- [1. myers.faculty.chemistry.harvard.edu](http://myers.faculty.chemistry.harvard.edu) [[myers.faculty.chemistry.harvard.edu](http://myers.faculty.chemistry.harvard.edu)]
- [2. baranlab.org](http://baranlab.org) [[baranlab.org](http://baranlab.org)]
- [3. researchgate.net](http://researchgate.net) [[researchgate.net](http://researchgate.net)]
- [4. uwindsor.ca](http://uwindsor.ca) [[uwindsor.ca](http://uwindsor.ca)]
- To cite this document: BenchChem. [Technical Support Center: Solubility Optimization for N-Methyl-2-naphthamide]. BenchChem, [2026]. [Online PDF]. Available at: [<https://www.benchchem.com/product/b1605573/docs#technical-support-center-solubility-optimization-for-n-methyl-2-naphthamide>]

---

### Disclaimer & Data Validity:

The information provided in this document is for Research Use Only (RUO) and is strictly not intended for diagnostic or therapeutic procedures. While BenchChem strives to provide accurate protocols, we make no warranties, express or implied, regarding the fitness of this product for every specific experimental setup.

**Technical Support:** The protocols provided are for reference purposes. Unsure if this reagent suits your experiment?

**Need Industrial/Bulk Grade?** [Request Custom Synthesis Quote](#)

# BenchChem

Our mission is to be the trusted global source of essential and advanced chemicals, empowering scientists and researchers to drive progress in science and industry.

## Contact

Address: 3281 E Guasti Rd

Ontario, CA 91761, United States

Phone: (601) 213-4426

Email: [info@benchchem.com](mailto:info@benchchem.com)

[Contact our Ph.D. Support Team for a compatibility check](#)