

Synthesis of 1-(2-(2-Ethoxyethoxy)ethoxy)butane: A Technical Guide

Author: BenchChem Technical Support Team. **Date:** April 2026

Compound of Interest

Compound Name:	1-(2-(2-Ethoxyethoxy)ethoxy)butane
CAS No.:	3895-17-8
Cat. No.:	B1605518

[Get Quote](#)

This in-depth technical guide provides a comprehensive overview of the synthesis of **1-(2-(2-ethoxyethoxy)ethoxy)butane**, a dialkyl ether of triethylene glycol. This document is intended for researchers, scientists, and professionals in the field of drug development and organic synthesis.

Introduction

1-(2-(2-Ethoxyethoxy)ethoxy)butane is a high-boiling, colorless liquid with applications as a solvent, plasticizer, and intermediate in various chemical syntheses. Its amphiphilic nature, arising from the combination of a hydrophobic butyl group and a hydrophilic polyether chain, makes it a versatile compound in a range of formulations. The primary and most established method for its synthesis is the Williamson ether synthesis.

Synthetic Pathways

The synthesis of **1-(2-(2-ethoxyethoxy)ethoxy)butane** is most effectively achieved through the Williamson ether synthesis, an S_N2 reaction between an alkoxide and an alkyl halide.[1]

[2][3] Two logical retrosynthetic disconnections of the target molecule reveal two primary synthetic routes:

- Route A: Reaction of triethylene glycol monoethyl ether with a butyl halide.
- Route B: Reaction of triethylene glycol monobutyl ether with an ethyl halide.

Both routes are viable, and the choice between them may be dictated by the availability and cost of the starting materials. For the purpose of this guide, a detailed protocol for Route A will be presented.

Signaling Pathway Diagram

The logical flow of the synthetic process can be visualized as a signaling pathway, where each step represents a transformation of the starting materials into the final product.

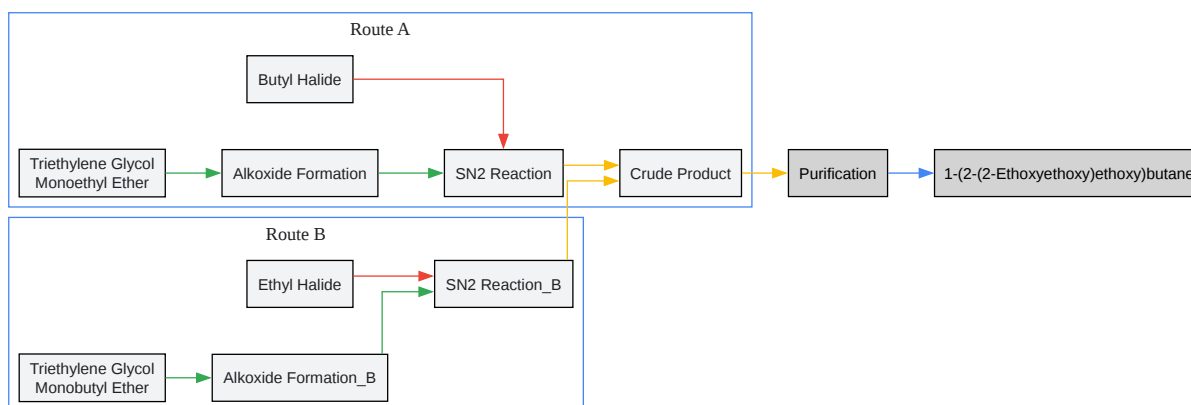

[Click to download full resolution via product page](#)

Caption: Synthetic routes to **1-(2-(2-Ethoxyethoxy)ethoxy)butane** via Williamson ether synthesis.

Experimental Protocol: Route A

This section details the experimental procedure for the synthesis of **1-(2-(2-ethoxyethoxy)ethoxy)butane** starting from triethylene glycol monoethyl ether and 1-bromobutane.

Materials:

- Triethylene glycol monoethyl ether (TGMEE)
- Sodium hydride (NaH), 60% dispersion in mineral oil
- 1-Bromobutane
- Anhydrous N,N-Dimethylformamide (DMF)
- Diethyl ether
- Saturated aqueous ammonium chloride (NH₄Cl) solution
- Brine (saturated aqueous NaCl solution)
- Anhydrous magnesium sulfate (MgSO₄)

Instrumentation:

- Round-bottom flask
- Magnetic stirrer and stir bar
- Reflux condenser
- Heating mantle or oil bath
- Separatory funnel

- Rotary evaporator
- Apparatus for fractional distillation under reduced pressure

Experimental Workflow Diagram

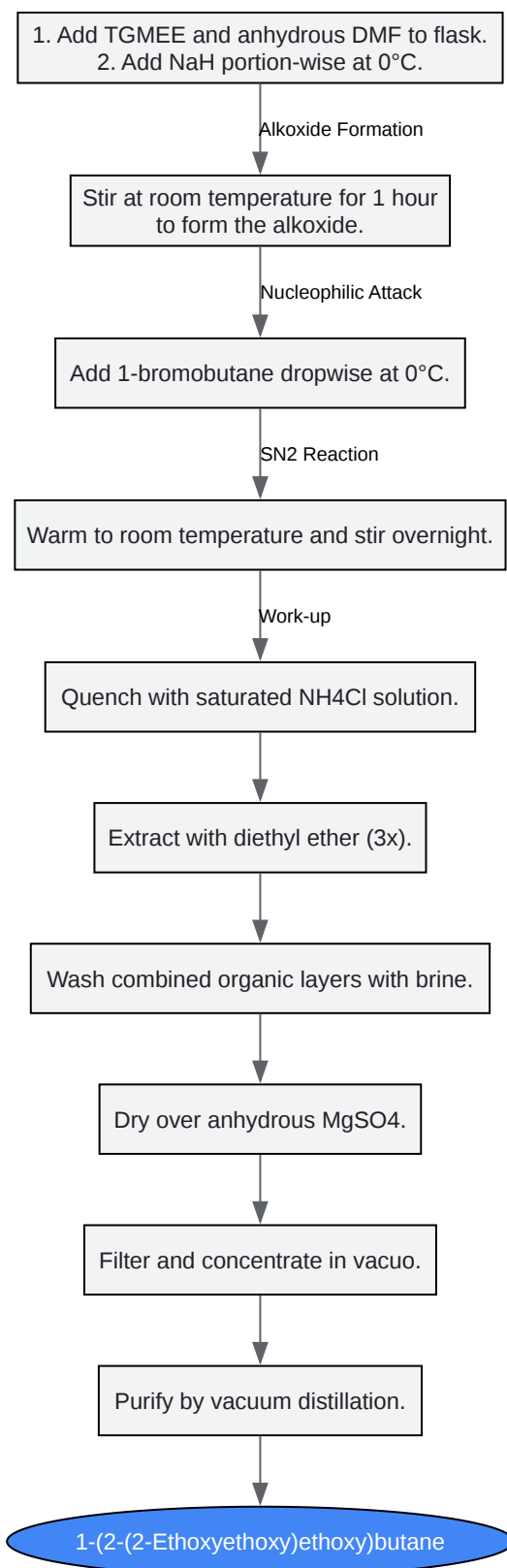

[Click to download full resolution via product page](#)

Caption: Step-by-step workflow for the synthesis and purification of the target compound.

Procedure:

- **Alkoxide Formation:** To a flame-dried round-bottom flask under an inert atmosphere (e.g., nitrogen or argon), add triethylene glycol monoethyl ether (1.0 eq) and anhydrous DMF. Cool the solution to 0°C in an ice bath. Carefully add sodium hydride (1.1 eq) portion-wise, ensuring the temperature remains below 5°C. After the addition is complete, remove the ice bath and stir the mixture at room temperature for 1 hour. The evolution of hydrogen gas should cease, indicating the formation of the sodium alkoxide.
- **S_(N)2 Reaction:** Cool the reaction mixture back to 0°C and add 1-bromobutane (1.05 eq) dropwise via a syringe or dropping funnel. After the addition, allow the reaction to warm to room temperature and stir overnight.
- **Work-up:** Carefully quench the reaction by the slow addition of a saturated aqueous solution of ammonium chloride. Transfer the mixture to a separatory funnel and extract with diethyl ether. The aqueous layer should be extracted two more times with diethyl ether.
- **Purification:** Combine the organic extracts and wash with brine. Dry the organic layer over anhydrous magnesium sulfate, filter, and concentrate the solvent using a rotary evaporator. The crude product is then purified by fractional distillation under reduced pressure to yield **1-(2-(2-ethoxyethoxy)ethoxy)butane** as a colorless liquid.

Data Presentation

The following tables summarize the key quantitative data for the starting materials and the final product. Note: As experimental data for the final product is not readily available in the literature, the yield is an estimate based on similar Williamson ether syntheses, and the spectral data is predicted based on the chemical structure and known values for similar compounds.

Table 1: Physicochemical Properties

Compound	Molecular Formula	Molar Mass (g/mol)	Boiling Point (°C)	Density (g/cm ³)
Triethylene Glycol Monoethyl Ether	C(8)H({18})O(4)	178.23	247-253	1.021
1-Bromobutane	C(_4)H(_9)Br	137.02	101-103	1.276
1-(2-(2-Ethoxyethoxy)ethoxy)butane	C({10})H({22})O(_3)	190.28[4]	104-105 @ 13 mmHg	~0.977[5]

Table 2: Estimated Reaction Parameters and Yield

Parameter	Value
Reaction Time	12-18 hours
Reaction Temperature	Room Temperature
Estimated Yield	75-85%

Table 3: Predicted Spectroscopic Data

Spectroscopy	Predicted Peaks
^1H NMR (CDCl_3), 400 MHz)	δ (ppm): 3.65-3.50 (m, 10H, -OCH ₂ CH ₂ O-), 3.45 (t, 2H, -OCH ₂ CH ₂ CH ₂ CH ₃), 1.55 (m, 2H, -OCH ₂ CH ₂ CH ₂ CH ₃), 1.35 (m, 2H, -OCH ₂ CH ₂ CH ₂ CH ₃), 1.20 (t, 3H, -OCH ₂ CH ₂ CH ₃), 0.90 (t, 3H, -CH ₂ CH ₃)
^{13}C NMR (CDCl_3), 100 MHz)	δ (ppm): 71.0, 70.8, 70.6, 70.4, 70.2 (polyether carbons), 66.7 (-OCH ₂ CH ₃), 31.8 (-OCH ₂ CH ₂ CH ₂ CH ₃), 19.4 (-OCH ₂ CH ₂ CH ₂ CH ₃), 15.2 (-OCH ₂ CH ₃), 13.9 (-CH ₂ CH ₃)
FT-IR (neat)	ν (cm ⁻¹): 2930-2860 (C-H stretch), 1110 (C-O-C stretch, strong)
Mass Spec. (EI)	m/z: 190 (M ⁺), 145, 117, 101, 87, 73, 59, 45

Conclusion

This technical guide outlines a reliable and straightforward method for the synthesis of **1-(2-(2-ethoxyethoxy)ethoxy)butane** via the Williamson ether synthesis. The provided experimental protocol and supplementary data offer a solid foundation for researchers to successfully prepare this compound in a laboratory setting. Further optimization of reaction conditions may lead to improved yields and purity. The predicted spectral data serves as a useful reference for the characterization of the final product.

Need Custom Synthesis?

BenchChem offers custom synthesis for rare earth carbides and specific isotopic labeling.

Email: info@benchchem.com or [Request Quote Online](#).

References

- [1. Williamson ether synthesis - Wikipedia \[en.wikipedia.org\]](#)
- [2. masterorganicchemistry.com \[masterorganicchemistry.com\]](#)
- [3. Williamson Ether Synthesis - Chemistry Steps \[chemistrysteps.com\]](#)
- [4. 1-\(2-\(2-Ethoxyethoxy\)ethoxy\)butane | 3895-17-8 | Benchchem \[benchchem.com\]](#)
- [5. 1-\(2-\(2-Ethoxyethoxy\)ethoxy\)butane \[myskinrecipes.com\]](#)
- To cite this document: BenchChem. [Synthesis of 1-(2-(2-Ethoxyethoxy)ethoxy)butane: A Technical Guide]. BenchChem, [2026]. [Online PDF]. Available at: [\[https://www.benchchem.com/product/b1605518/docs#synthesis-of-1-2-2-ethoxyethoxy-ethoxy-butane-a-technical-guide\]](https://www.benchchem.com/product/b1605518/docs#synthesis-of-1-2-2-ethoxyethoxy-ethoxy-butane-a-technical-guide)

Disclaimer & Data Validity:

The information provided in this document is for Research Use Only (RUO) and is strictly not intended for diagnostic or therapeutic procedures. While BenchChem strives to provide accurate protocols, we make no warranties, express or implied, regarding the fitness of this product for every specific experimental setup.

Technical Support: The protocols provided are for reference purposes. Unsure if this reagent suits your experiment?

Need Industrial/Bulk Grade? [Request Custom Synthesis Quote](#)

BenchChem

Our mission is to be the trusted global source of essential and advanced chemicals, empowering scientists and researchers to drive progress in science and industry.

Contact

Address: 3281 E Guasti Rd

Ontario, CA 91761, United States

Phone: (601) 213-4426

Email: info@benchchem.com

Contact our Ph.D. Support Team for a compatibility check