

# Structural elucidation of Glycyl-beta-alanine using NMR spectroscopy

**Author:** BenchChem Technical Support Team. **Date:** May 2026

## Compound of Interest

Compound Name: Glycyl-beta-alanine

CAS No.: 7536-21-2

Cat. No.: B1605025

[Get Quote](#)

## Structural Elucidation of Glycyl- -Alanine Using NMR Spectroscopy

### Executive Summary

This technical guide outlines the systematic structural elucidation of Glycyl-

-alanine (Gly-

-Ala), a dipeptide of significant interest in peptidomimetic drug design due to the metabolic stability conferred by the

-amino acid residue. Unlike standard

-peptides, the incorporation of

-alanine introduces unique methylene spin systems that require specific NMR strategies to resolve.

This document details the experimental logic, solvent selection, and 2D NMR correlation pathways required to unambiguously verify the structure, sequence, and connectivity of this molecule.

## Chemical Context & Elucidation Strategy

Target Molecule: Glycyl-

-alanine Molecular Formula:

SMILES:NCC(=O)NCCC(=O)O

The structural elucidation hinges on three critical verification points:

- **Residue Identification:** Distinguishing the isolated Glycine spin system from the coupled -Alanine spin system.
- **Peptide Linkage:** Confirming the amide bond formation between the Glycine carboxyl and the -Alanine amine.
- **Sequence Directionality:** Proving Glycine is the N-terminus and -Alanine is the C-terminus (vs. -Alanyl-Glycine).

## The -Peptide Challenge

In standard

-peptides, the spin system is interrupted by the carbonyl carbon. In Gly-

-Ala, the

-alanine residue introduces an ethylene backbone (

) between the amide nitrogen and the carboxylic acid, creating a distinct

(or

) coupling pattern that is diagnostic of

-amino acids.

## Sample Preparation & Solvent Selection[1][2][3][4][5]

The choice of solvent dictates the visibility of exchangeable protons (NH, OH), which are critical for establishing peptide connectivity.

### Protocol 1: Solvent Selection

Solvent	Utility	Recommendation
Deuterium Oxide (D <sub>2</sub> O)	Excellent solubility for zwitterions. Simplifies spectrum by exchanging NH/OH to OD (signals disappear).	Use for Backbone Assignment: Ideal for clear resolution of coupling constants (J-values) without amide coupling interference.
DMSO-d <sub>6</sub>	Slows proton exchange, preserving Amide-NH and Amine-NH signals.	Use for Structural Proof: Mandatory for establishing sequence connectivity via HMBC/COSY involving the NH proton.

Critical Step: For full structural elucidation, DMSO-

is the primary solvent. The presence of the Amide-NH signal allows for the observation of couplings, which physically link the nitrogen to the carbon backbone.

### Protocol 2: Sample Preparation (DMSO- )

- Mass: Weigh 5–10 mg of Glycyl-L-Ala.
- Solvation: Dissolve in 600

L of DMSO-

(99.9% D).

- Reference: Add 0.03% TMS (Tetramethylsilane) as an internal standard ( ppm).
- Vessel: Transfer to a high-precision 5mm NMR tube.
- Temperature: Equilibrate probe to 298 K ( ).

## 1H NMR Analysis (Proton Assignment)

In DMSO-

, we expect five distinct proton environments.

## Predicted Chemical Shifts & Multiplicities

Note: Shifts are approximate and pH/concentration dependent.

Residue	Position	Proton Count	Multiplicity	Approx. Shift (ppm)	Coupling Logic
Gly	-CH	2H	Singlet/Doubl et*	3.5 – 3.7	Singlet if N-term is exchanging fast; Doublet if coupled to .
Gly	Amine	2-3H	Broad Singlet	7.8 – 8.2	Broad due to quadrupole relaxation and exchange.
-Ala	( -CH )	2H	Quartet/Multi plet	3.2 – 3.4	Coupled to both Amide-NH and -CH .
-Ala	( -CH )	2H	Triplet	2.3 – 2.5	Coupled only to -CH .
Linker	Amide NH	1H	Triplet (Broad)	8.0 – 8.5	Coupled to -Ala -CH .
Term	Acid COOH	1H	Broad	10.0 - 12.0	Often invisible due

to exchange.

---

Diagnostic Feature: The

-Alanine residue presents as two coupled triplets (or multiplets) in the aliphatic region. The Glycine

-CH

appears as a singlet (in

) or a broad signal distinct from the ethyl spin system.

## **<sup>13</sup>C NMR Analysis (Carbon Backbone)**

Carbon-13 NMR confirms the presence of two distinct carbonyls, distinguishing the amide linkage from the terminal acid.

Carbon Type	Assignment	Approx. Shift (ppm)	Notes
Carbonyl	Gly Amide	165 – 170	Upfield of the acid carbonyl.
Carbonyl	-Ala Acid	172 – 176	Downfield signal.
Aliphatic	Gly -CH	40 – 42	
Aliphatic	-Ala -CH ( )	35 – 37	Deshielded by Nitrogen.
Aliphatic	-Ala -CH ( )	33 – 35	Shielded relative to N-C.

## 2D NMR Verification (Connectivity & Sequence)

To prove the structure is Gly-

-Ala and not

-Ala-Gly, 2D correlations are required.

## COSY (Correlation Spectroscopy)

Purpose: Identifies isolated spin systems.

- System A (  
-Ala): Cross-peak between  
2.4 (  
-CH  
) and  
3.3 (  
-CH  
).  
• System B (Gly): No correlations to aliphatic protons (isolated CH  
).  
• System C (Amide): In DMSO, cross-peak between Amide-NH (  
8.2) and  
-Ala  
-CH  
(  
3.3). This proves the Amide NH is attached to the  
-Alanine unit.

## HMBC (Heteronuclear Multiple Bond Correlation)

Purpose: Long-range coupling (2-3 bonds) to bridge the heteroatoms. This is the definitive experiment for sequencing.

Key Correlations for Proof:

- Gly

to Gly

: Strong 2-bond correlation.

- -Ala

to Gly

:The "Smoking Gun". The amide proton of

-alanine will show a 2-bond correlation to its own

-carbon and a 3-bond correlation to the Glycine Carbonyl. This links the two residues.

- -Ala

-CH

to Acid

: Confirms the C-terminus.

## Elucidation Workflow Diagram

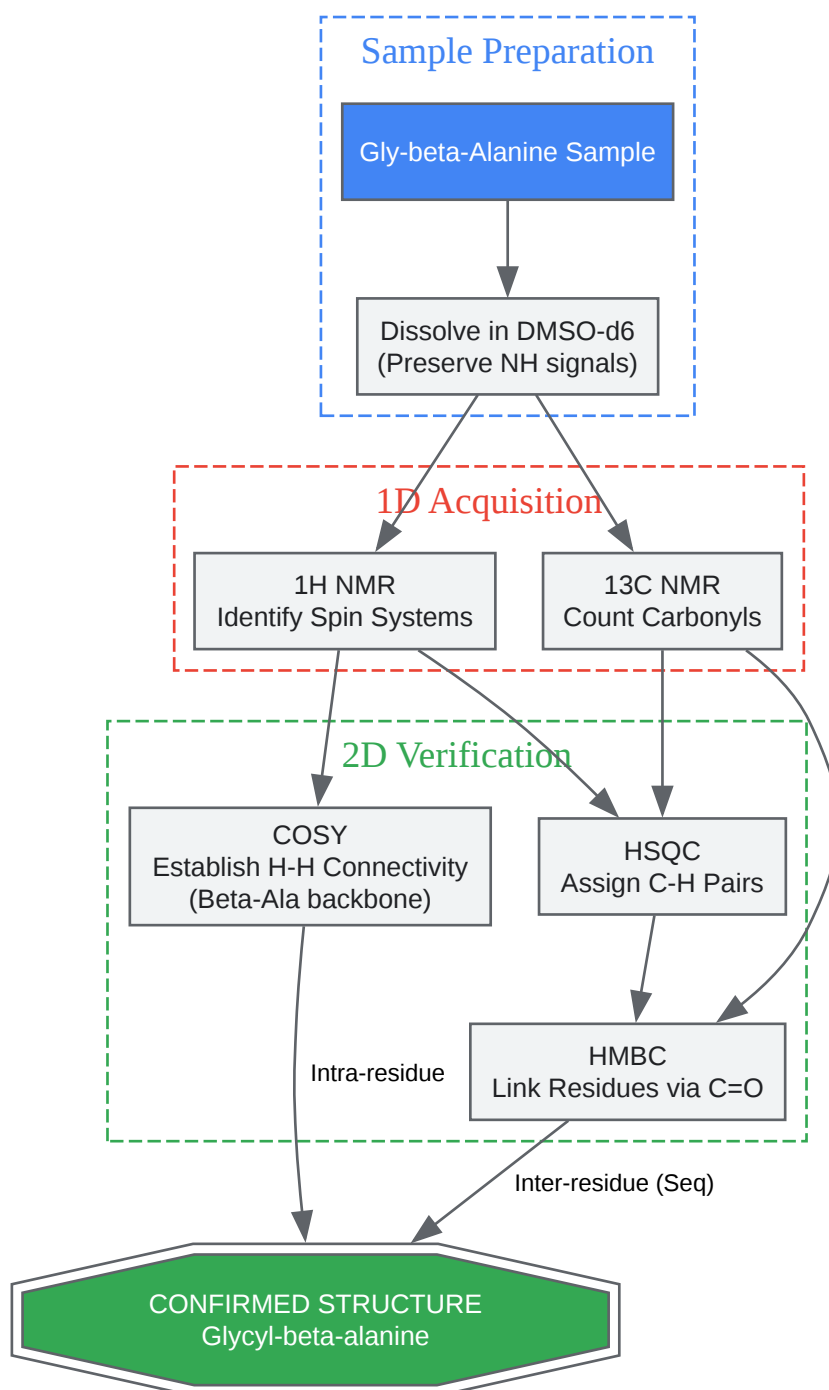

[Click to download full resolution via product page](#)

Caption: Systematic workflow for the structural elucidation of Glycyl-beta-alanine, highlighting the progression from sample prep to sequence confirmation.

## Sequence Logic Diagram (HMBC)

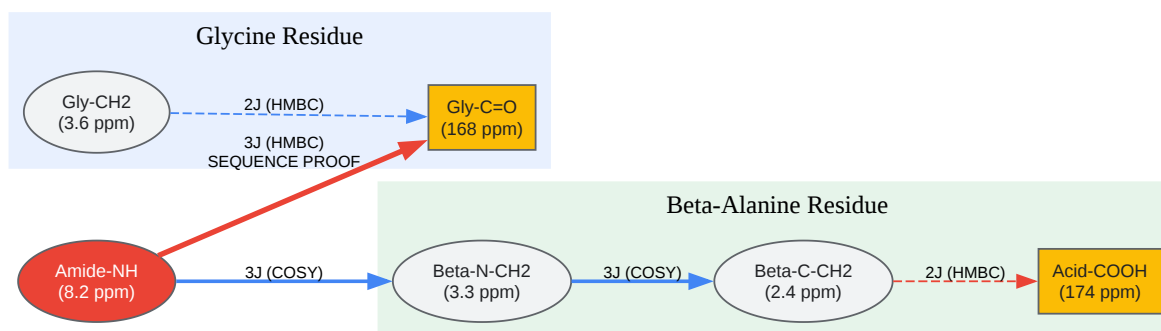

[Click to download full resolution via product page](#)

Caption: Critical NMR correlations. Blue lines represent scalar couplings (COSY); the Red line represents the inter-residue HMBC correlation that definitively proves the Gly

-Ala sequence.

## References

- Babij, N. R., et al. (2016). "NMR Chemical Shifts of Trace Impurities: Industrially Preferred Solvents Used in Process and Green Chemistry." *Organic Process Research & Development*. (Provides solvent reference data for DMSO and D2O).
- Gottlieb, H. E., Kotlyar, V., & Nudelman, A. (1997).[1] "NMR Chemical Shifts of Common Laboratory Solvents as Trace Impurities." *The Journal of Organic Chemistry*. (Standard reference for residual solvent peaks).
- Wishart, D. S., et al. (1995). "<sup>1</sup>H, <sup>13</sup>C and <sup>15</sup>N chemical shift referencing in biomolecular NMR." *Journal of Biomolecular NMR*. (Protocols for peptide referencing).
- BMRB (Biological Magnetic Resonance Data Bank). "Chemical Shift Statistics." (Reference for standard amino acid shifts).
- Pretsch, E., Bühlmann, P., & Badertscher, M. (2009). *Structure Determination of Organic Compounds*. Springer. (Authoritative text on interpreting coupling constants and chemical shifts).

**Need Custom Synthesis?**

BenchChem offers custom synthesis for rare earth carbides and specific isotopic labeling.

Email: [info@benchchem.com](mailto:info@benchchem.com) or [Request Quote Online](#).

## Sources

- 1. [scs.illinois.edu](https://scs.illinois.edu) [[scs.illinois.edu](https://scs.illinois.edu)]
- To cite this document: BenchChem. [Structural elucidation of Glycyl-beta-alanine using NMR spectroscopy]. BenchChem, [2026]. [Online PDF]. Available at: [<https://www.benchchem.com/product/b1605025/docs#structural-elucidation-of-glycyl-beta-alanine-using-nmr-spectroscopy>]

---

**Disclaimer & Data Validity:**

The information provided in this document is for Research Use Only (RUO) and is strictly not intended for diagnostic or therapeutic procedures. While BenchChem strives to provide accurate protocols, we make no warranties, express or implied, regarding the fitness of this product for every specific experimental setup.

**Technical Support:** The protocols provided are for reference purposes. Unsure if this reagent suits your experiment?

**Need Industrial/Bulk Grade?** [Request Custom Synthesis Quote](#)

## BenchChem

Our mission is to be the trusted global source of essential and advanced chemicals, empowering scientists and researchers to drive progress in science and industry.

### Contact

Address: 3281 E Guasti Rd

Ontario, CA 91761, United States

Phone: (601) 213-4426

Email: [info@benchchem.com](mailto:info@benchchem.com)

Contact our Ph.D. Support Team for a compatibility check