

# Personal protective equipment for handling 2'-Chlorothymidine

**Author:** BenchChem Technical Support Team. **Date:** May 2026

## Compound of Interest

Compound Name: 2'-Chlorothymidine

CAS No.: 54898-34-9

Cat. No.: B1605289

[Get Quote](#)

## Operational Safety Protocol: Handling 2'-Chlorothymidine

### Executive Summary & Risk Mechanism

**2'-Chlorothymidine** is not a standard bench chemical; it is a modified nucleoside analog. While often used as a tool compound to study polymerase fidelity or viral inhibition, its structural similarity to natural thymidine presents a "silent" biological hazard.

The "Trojan Horse" Mechanism: Unlike acute toxins (e.g., cyanide) that cause immediate physiological distress, nucleoside analogs pose a genotoxic risk. The 2'-chloro modification alters the sugar pucker (favoring C3'-endo conformation), mimicking RNA-like stability while retaining DNA-incorporation potential.

- Cellular Uptake: The molecule is transported into cells via nucleoside transporters (hENT/hCNT).
- Phosphorylation: Cellular kinases convert it to the triphosphate form.<sup>[1]</sup>

- Incorporation: DNA polymerases may mistakenly incorporate it into the genome.
- Consequence: This can lead to chain termination, stalling of replication forks, or point mutations.

Core Directive: Treat **2'-Chlorothymidine** as a Potential Germ Cell Mutagen and Reproductive Toxin. All protocols below are designed to prevent any mucosal or cutaneous absorption.

## Personal Protective Equipment (PPE) Matrix

Standard laboratory PPE is insufficient. The following matrix utilizes a "Control Banding" approach, elevating protection to match the compound's potency.

PPE Category	Specification	Rationale (Causality)
Hand Protection	Double-Gloving Strategy <sup>1</sup> . Inner: Nitrile (min 0.11 mm) <sup>2</sup> . Outer: Extended-cuff Nitrile (min 0.14 mm)	Nucleosides are small molecules (<300 Da) that can permeate thin latex. Double layers create a tortuous path, delaying breakthrough.
Respiratory	N95 (Minimum) or PAPRMandatory if outside Fume Hood	The solid powder is electrostatic. Inhalation delivers the agent directly to the bloodstream, bypassing first-pass hepatic metabolism.
Eye/Face	Chemical Goggles (Indirect Venting)	Safety glasses leave gaps. Goggles seal the ocular mucosa, a rapid absorption route for hydrophilic nucleosides.
Body	Tyvek® Lab Coat (Closed front, elastic cuffs)	Cotton coats absorb and hold powders against the skin. Tyvek repels particulates and prevents "drag-home" contamination.

# Operational Workflow: The "Zero-Exposure" Protocol

## Phase A: Engineering Controls

- Primary Containment: All manipulation of dry powder must occur within a certified Chemical Fume Hood or Class II Biological Safety Cabinet (BSC).
- Airflow Check: Verify face velocity is between 80–100 fpm before opening the vial.

## Phase B: Weighing & Solubilization (Critical Step)

This is the highest-risk moment due to potential aerosolization of the powder.

- Preparation: Place a disposable absorbent mat (plastic side down) in the hood. Have a pre-tared vial ready.
- Static Control: Use an anti-static gun on the vial if available. Nucleoside powders are often "fly-away" and electrostatic.
- Transfer: Use a disposable spatula. Do not use metal spatulas that require washing; dispose of the tool as hazardous waste immediately.
- Solubilization: Add solvent (e.g., DMSO or Water) immediately after weighing.
  - Why: Once in solution, the inhalation risk drops to near zero (unless aerosolized), shifting the risk to splash/skin absorption.

## Phase C: Decontamination

Nucleoside analogs are stable. Simple water washing is ineffective.

- Agent: 10% Bleach (Sodium Hypochlorite) followed by 70% Ethanol.
- Mechanism: Bleach oxidizes the heterocyclic ring, disrupting the hydrogen-bonding capability of the base.

## Visualized Workflows

## Diagram 1: The "Trojan Horse" Risk Logic

This diagram illustrates why standard PPE fails and why the specific controls above are necessary.

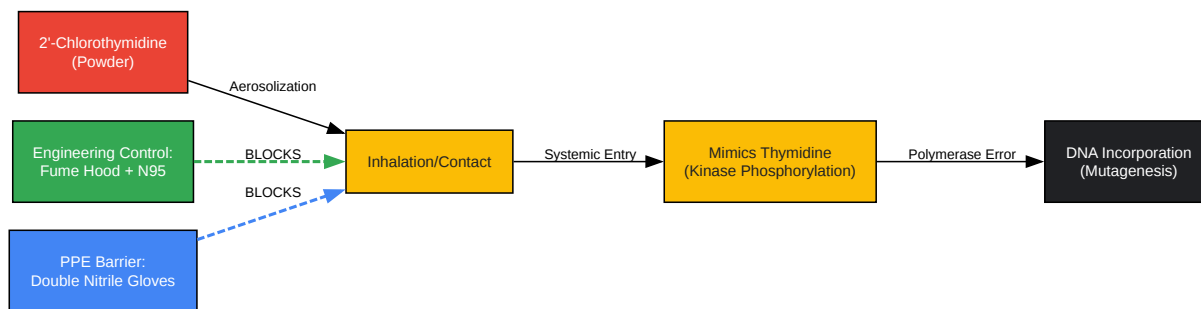

[Click to download full resolution via product page](#)

Caption: Figure 1. Mechanism of Action and Barrier Logic. The diagram highlights the critical intervention points where PPE and Engineering controls prevent the biological cascade of mutagenesis.

## Diagram 2: Safe Handling Workflow

Step-by-step decision tree for the researcher.

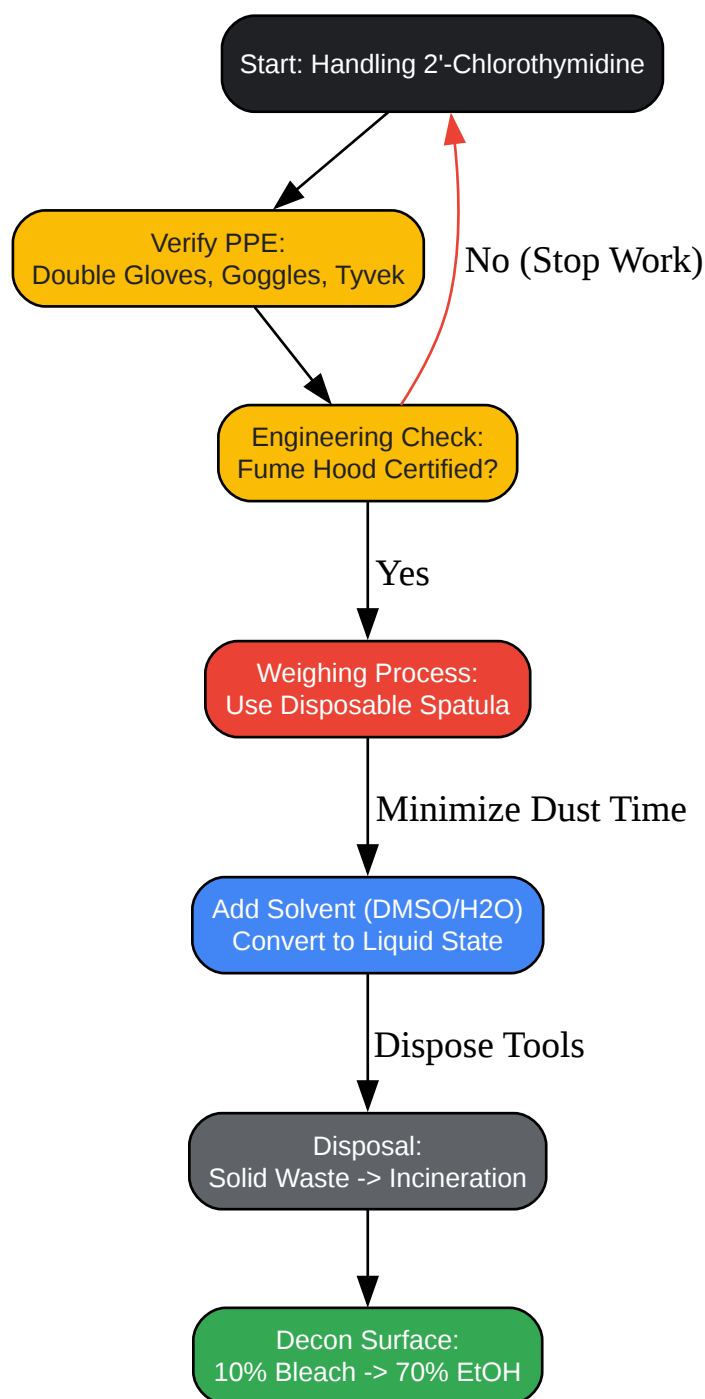

[Click to download full resolution via product page](#)

Caption: Figure 2. Operational Workflow. A linear progression ensuring containment is maintained from the moment of vial opening until final decontamination.

## Disposal & Emergency Response

## Waste Management

- Solid Waste: Vials, spatulas, and contaminated gloves must be segregated into Yellow Hazardous Waste Bags (or site-specific equivalent for cytotoxic/mutagenic waste).
- Destruction Method: High-Temperature Incineration (>1000°C) is required. Do not autoclave; heat alone may not destroy the chemical structure sufficiently to prevent environmental leaching.

## Accidental Exposure Response

- Skin Contact: Immediately wash with soap and water for 15 minutes. Do not use ethanol on skin (it enhances absorption).
- Eye Contact: Flush at an eyewash station for 15 minutes. Hold eyelids open.
- Spill Cleanup (Powder):
  - Cover spill with wet paper towels (to prevent dust).
  - Wipe up.<sup>[2]</sup>
  - Clean area with 10% bleach, then water.

## References

- PubChem. (n.d.). **2'-Chlorothymidine** Compound Summary. National Library of Medicine. Retrieved from [\[Link\]](#)
- Occupational Safety and Health Administration (OSHA). (2016). Controlling Occupational Exposure to Hazardous Drugs. United States Department of Labor. Retrieved from [\[Link\]](#)<sup>[3]</sup>
- Centers for Disease Control and Prevention (CDC). (2023). Biosafety in Microbiological and Biomedical Laboratories (BMBL) 6th Edition. Retrieved from [\[Link\]](#)
- National Institutes of Health (NIH). (2019). Guidelines for Research Involving Recombinant or Synthetic Nucleic Acid Molecules. Retrieved from [\[Link\]](#)

### Need Custom Synthesis?

BenchChem offers custom synthesis for rare earth carbides and specific isotopic labeling.

Email: [info@benchchem.com](mailto:info@benchchem.com) or [Request Quote Online](#).

## Sources

- [1. azolifesciences.com \[azolifesciences.com\]](https://www.azolifesciences.com)
- [2. epcc.edu \[epcc.edu\]](https://www.epcc.edu)
- [3. cdc.gov \[cdc.gov\]](https://www.cdc.gov)
- To cite this document: BenchChem. [Personal protective equipment for handling 2'-Chlorothymidine]. BenchChem, [2026]. [Online PDF]. Available at: [\[https://www.benchchem.com/product/b1605289/docs#personal-protective-equipment-for-handling-2-chlorothymidine\]](https://www.benchchem.com/product/b1605289/docs#personal-protective-equipment-for-handling-2-chlorothymidine)

### Disclaimer & Data Validity:

The information provided in this document is for Research Use Only (RUO) and is strictly not intended for diagnostic or therapeutic procedures. While BenchChem strives to provide accurate protocols, we make no warranties, express or implied, regarding the fitness of this product for every specific experimental setup.

**Technical Support:** The protocols provided are for reference purposes. Unsure if this reagent suits your experiment?

**Need Industrial/Bulk Grade?** [Request Custom Synthesis Quote](#)

## BenchChem

Our mission is to be the trusted global source of essential and advanced chemicals, empowering scientists and researchers to drive progress in science and industry.

### Contact

Address: 3281 E Guasti Rd  
Ontario, CA 91761, United States  
Phone: (601) 213-4426  
Email: [info@benchchem.com](mailto:info@benchchem.com)

Contact our Ph.D. Support Team for a compatibility check