

Introduction: The Significance of a Versatile Phenylacetic Acid Derivative

Author: BenchChem Technical Support Team. **Date:** May 2026

Compound of Interest

Compound Name:	2-Isopropoxy-2-phenylacetic acid
CAS No.:	5394-87-6
Cat. No.:	B1605838

[Get Quote](#)

2-Isopropoxy-2-phenylacetic acid is a specialized organic compound belonging to the α -alkoxy carboxylic acid family. Its structure, featuring a chiral center and the isopropoxy ether linkage alpha to a phenyl ring and a carboxylic acid, makes it a valuable building block in medicinal chemistry and organic synthesis. While not a household name, this molecule serves as a critical intermediate in the synthesis of more complex active pharmaceutical ingredients (APIs). Notably, it is a precursor in some synthetic routes to Ipratropium Bromide, an anticholinergic drug used to treat chronic obstructive pulmonary disease (COPD), asthma, and bronchitis.^{[1][2][3]} The controlled and efficient synthesis of **2-isopropoxy-2-phenylacetic acid** is therefore a subject of considerable interest to researchers in process chemistry and drug development.

This guide provides a comprehensive overview of a robust and widely applicable synthetic strategy for **2-isopropoxy-2-phenylacetic acid**, grounded in fundamental organic chemistry principles. We will delve into the causality behind experimental choices, provide detailed, self-validating protocols, and outline a full characterization workflow for the final product.

Part 1: A Strategic Approach to Synthesis

The most logical and field-proven approach to constructing **2-isopropoxy-2-phenylacetic acid** is a three-step sequence starting from the readily available precursor, mandelic acid. This strategy is designed to selectively introduce the isopropoxy group without interfering with the carboxylic acid functionality.

The overall synthetic pathway is as follows:

- **Protection via Esterification:** The carboxylic acid group of mandelic acid is temporarily converted into an ester. This is a critical step because the acidic proton of the carboxylic acid would interfere with the strongly basic conditions required for the subsequent etherification step.
- **Ether Formation via Williamson Synthesis:** The hydroxyl group of the mandelate ester is deprotonated to form an alkoxide, which then acts as a nucleophile to displace a halide from an isopropyl source, forming the desired ether linkage.[\[4\]](#)[\[5\]](#)[\[6\]](#)
- **Deprotection via Saponification:** The ester is hydrolyzed under basic conditions to yield the sodium salt of the target carboxylic acid, which is then protonated in an acidic workup to give the final product.[\[7\]](#)[\[8\]](#)

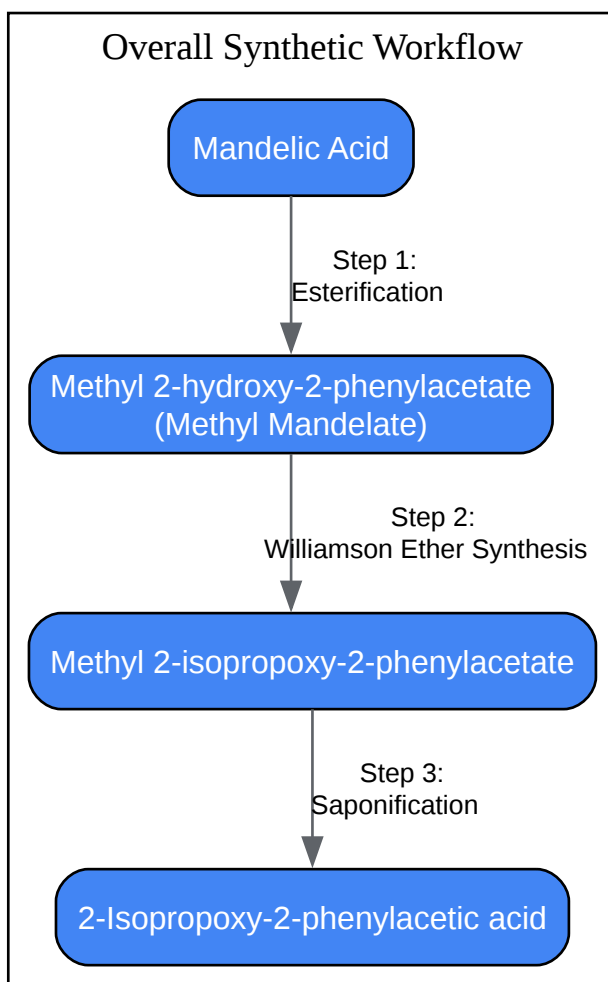

[Click to download full resolution via product page](#)

Caption: High-level overview of the three-step synthesis of **2-isopropoxy-2-phenylacetic acid**.

Part 2: Detailed Experimental Protocols & Mechanistic Insights

Step 1: Esterification of Mandelic Acid to Methyl Mandelate

The initial protection of the carboxylic acid is most commonly achieved by Fischer esterification. This acid-catalyzed reaction with an excess of alcohol (methanol) shifts the equilibrium toward the product.

Causality and Experimental Choices:

- **Catalyst:** A strong acid like sulfuric acid (H_2SO_4) is used to protonate the carbonyl oxygen of the carboxylic acid, making the carbonyl carbon more electrophilic and susceptible to nucleophilic attack by methanol.
- **Reagent:** Methanol is used in large excess to act as both the reactant and the solvent, driving the reversible reaction towards the formation of the methyl ester according to Le Châtelier's principle.
- **Reaction Control:** The reaction is typically heated to reflux to increase the reaction rate. Progress can be monitored by Thin Layer Chromatography (TLC) by observing the disappearance of the more polar mandelic acid spot.

Protocol 1: Synthesis of Methyl 2-hydroxy-2-phenylacetate

- To a 500 mL round-bottom flask equipped with a magnetic stirrer and a reflux condenser, add mandelic acid (30.4 g, 0.2 mol).
- Add 200 mL of anhydrous methanol. Stir until the mandelic acid is largely dissolved.
- Carefully add concentrated sulfuric acid (2 mL) dropwise to the stirring solution.
- Heat the mixture to reflux (approx. 65°C) and maintain for 4-6 hours.
- After cooling to room temperature, neutralize the excess acid by slowly adding a saturated solution of sodium bicarbonate until effervescence ceases.
- Reduce the volume of the solvent by approximately half using a rotary evaporator.
- Add 200 mL of water and extract the aqueous phase with ethyl acetate (3 x 100 mL).
- Combine the organic extracts, wash with brine (1 x 100 mL), dry over anhydrous sodium sulfate (Na_2SO_4), filter, and concentrate under reduced pressure to yield methyl mandelate as a pale yellow oil or low-melting solid. The product is often of sufficient purity for the next step.

Step 2: Williamson Ether Synthesis

This is the key bond-forming step where the isopropoxy group is installed. It is a classic S_N2 reaction.[6]

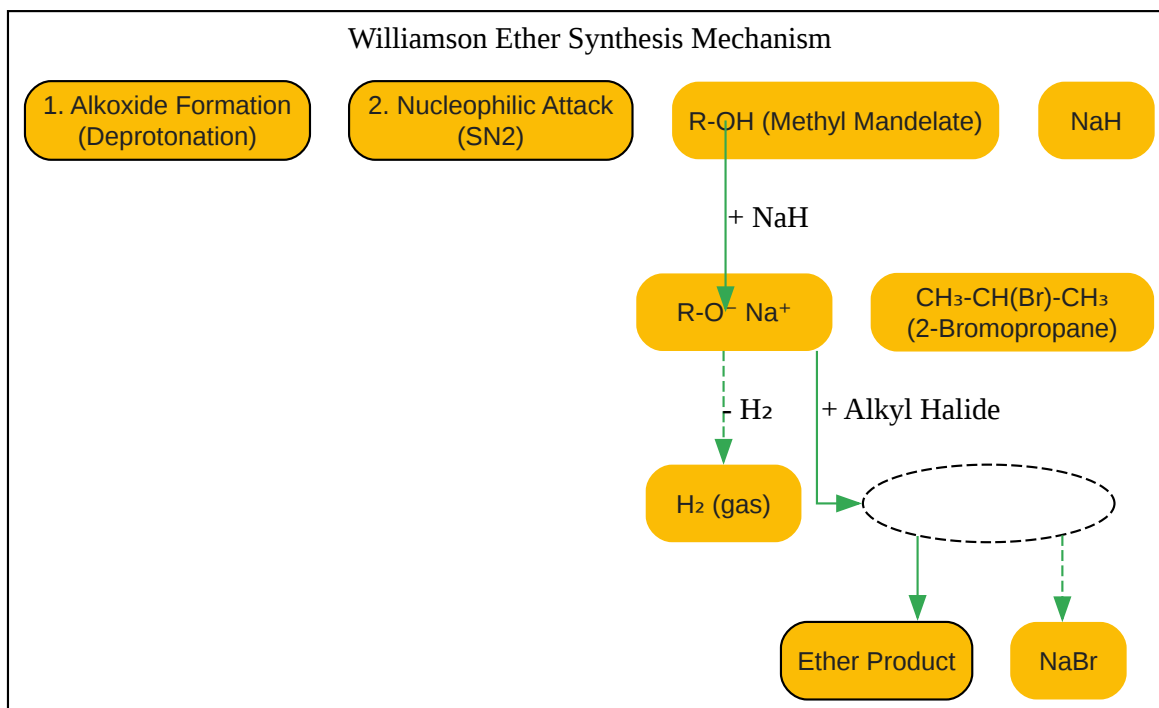

[Click to download full resolution via product page](#)

Caption: Mechanism of the Williamson ether synthesis for forming the isopropoxy ether.

Causality and Experimental Choices:

- **Base:** Sodium hydride (NaH) is an ideal base for this step.[5] It is a strong, non-nucleophilic base that irreversibly deprotonates the alcohol to form the sodium alkoxide. The reaction produces hydrogen gas, which bubbles out of the solution, driving the deprotonation to completion.

- Solvent: Anhydrous tetrahydrofuran (THF) is a suitable polar aprotic solvent. It effectively solvates the sodium cation but does not solvate the alkoxide nucleophile, leaving it "naked" and highly reactive for the S_N2 attack.[4]
- Alkylating Agent: 2-bromopropane is a common and effective source for the isopropyl group. As a secondary halide, it is susceptible to a competing E2 elimination reaction, which is minimized by controlling the temperature.[5]

Protocol 2: Synthesis of Methyl 2-isopropoxy-2-phenylacetate

- Set up a flame-dried 500 mL three-neck round-bottom flask under a nitrogen atmosphere, equipped with a magnetic stirrer, a dropping funnel, and a condenser.
- Add sodium hydride (9.6 g, 0.24 mol, 60% dispersion in mineral oil) to the flask. Wash the NaH with anhydrous hexane (2 x 30 mL) to remove the mineral oil, carefully decanting the hexane each time.
- Add 150 mL of anhydrous THF to the flask.
- Dissolve the methyl mandelate (33.2 g, 0.2 mol) from Step 1 in 50 mL of anhydrous THF and add it to the dropping funnel.
- Cool the NaH suspension to 0°C using an ice bath.
- Add the methyl mandelate solution dropwise to the stirred NaH suspension over 30-45 minutes. Vigorous hydrogen evolution will be observed.
- After the addition is complete, allow the mixture to warm to room temperature and stir for an additional hour to ensure complete alkoxide formation.
- Add 2-bromopropane (36.9 g, 0.3 mol) dropwise via the dropping funnel.
- Heat the reaction mixture to reflux and maintain for 8-12 hours. Monitor the reaction progress by TLC until the starting material is consumed.
- Cool the mixture to 0°C and cautiously quench the reaction by the slow, dropwise addition of water (approx. 20 mL) to destroy any unreacted NaH.

- Add 200 mL of water and transfer the mixture to a separatory funnel. Extract with diethyl ether (3 x 100 mL).
- Combine the organic layers, wash with brine, dry over anhydrous Na_2SO_4 , filter, and concentrate under reduced pressure. The crude product can be purified by vacuum distillation or column chromatography.

Step 3: Saponification (Ester Hydrolysis)

The final step is the deprotection of the carboxylic acid. Basic hydrolysis, or saponification, is used because it is an irreversible process, which ensures a high yield of the product.^[8]

Causality and Experimental Choices:

- Base: Sodium hydroxide (NaOH) is a strong nucleophile (OH^-) that attacks the electrophilic carbonyl carbon of the ester.
- Solvent System: A mixture of an alcohol (like methanol or ethanol) and water is used. The alcohol helps to solubilize the organic ester, while the water dissolves the NaOH, creating a homogeneous reaction environment.
- Work-up: After hydrolysis, the product exists as the sodium carboxylate salt. Acidification with a strong acid like HCl is required to protonate the carboxylate and precipitate the final carboxylic acid product.^[9]

Protocol 3: Synthesis of **2-Isopropoxy-2-phenylacetic acid**

- Dissolve the crude methyl 2-isopropoxy-2-phenylacetate from Step 2 in 150 mL of methanol in a 500 mL round-bottom flask.
- In a separate beaker, dissolve sodium hydroxide (12.0 g, 0.3 mol) in 100 mL of water.
- Add the NaOH solution to the ester solution and heat the mixture to reflux for 2-3 hours.
- Cool the reaction mixture and remove the methanol under reduced pressure.
- Dilute the remaining aqueous solution with 150 mL of water and wash with diethyl ether (2 x 50 mL) to remove any non-acidic impurities.

- Cool the aqueous layer in an ice bath and acidify to pH ~2 by the slow addition of concentrated hydrochloric acid. A white precipitate of **2-isopropoxy-2-phenylacetic acid** will form.
- Filter the solid product using a Büchner funnel, wash the filter cake with cold water, and dry under vacuum to yield the final product. Recrystallization from a suitable solvent (e.g., a toluene/hexane mixture) can be performed for further purification.

Part 3: Characterization and Data Analysis

Thorough characterization is essential to confirm the identity and purity of the synthesized **2-isopropoxy-2-phenylacetic acid**.

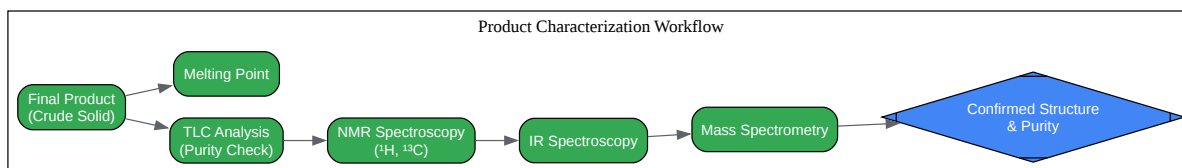

[Click to download full resolution via product page](#)

Caption: A typical workflow for the analytical characterization of the final product.

Spectroscopic Data

The following tables summarize the expected data from key analytical techniques.

Table 1: Expected ^1H NMR Spectral Data (400 MHz, CDCl_3)

Chemical Shift (δ) ppm	Multiplicity	Integration	Assignment	Rationale
~11.0 - 12.0	Broad Singlet	1H	-COOH	The acidic proton of the carboxylic acid is typically downfield and broad.
~7.30 - 7.45	Multiplet	5H	Ar-H	Protons of the monosubstituted phenyl ring.
~4.65	Singlet	1H	-CH-Ph	The methine proton alpha to the phenyl ring and oxygen.
~3.70	Septet	1H	-CH-(CH ₃) ₂	The methine proton of the isopropyl group, split by 6 adjacent protons.
~1.20	Doublet	3H	-CH-(CH ₃) ₂	One of the diastereotopic methyl groups of the isopropyl moiety.

| ~1.10 | Doublet | 3H | -CH-(CH₃)₂ | The other diastereotopic methyl group of the isopropyl moiety. |

Table 2: Expected IR Spectral Data (ATR)

Wavenumber (cm ⁻¹)	Intensity	Functional Group Assignment
2500-3300	Broad, Strong	O-H stretch (Carboxylic Acid)
~1710	Strong	C=O stretch (Carboxylic Acid Dimer)
~1100	Strong	C-O stretch (Ether)
3030-3080	Medium	C-H stretch (Aromatic)

| 2850-2980 | Medium | C-H stretch (Aliphatic) |

Mass Spectrometry (Electron Ionization - EI)

- Molecular Ion (M⁺): Expected at m/z = 194.
- Key Fragments: Look for loss of the carboxylic acid group (M-45), loss of the isopropyl group (M-43), and a prominent peak for the tropylium ion at m/z = 91.[\[10\]](#)

Conclusion

This guide has detailed a reliable and well-understood synthetic route for **2-isopropoxy-2-phenylacetic acid** from mandelic acid. By employing a strategic protection-etherification-deprotection sequence, the target molecule can be obtained in good yield and high purity. The rationale behind each experimental choice, from reagents to reaction conditions, has been explained to provide a deeper understanding of the process. The comprehensive characterization workflow ensures the final product meets the required standards for its use in further research and development, particularly in the pharmaceutical industry.

References

- Google Patents. CN111978316B - Synthesis method of ipratropium bromide.
- Google Patents. CN111269226B - Synthesis method of ipratropium bromide.
- ResearchGate. Ipratropium Bromide: Methods of Chemical and Biochemical Synthesis. [Online] Available at: [\[Link\]](#)

- J-STAGE. Synthesis of Optically Active α -Isopropyl-4-substituted Phenylacetic Acids by Asymmetric Hydrogenation. [Online] Available at: [\[Link\]](#)
- YouTube. Synthesis of Ipratropium bromide | Medicinal Chemistry -I | B. Pharm IV Semester. [Online] Available at: [\[Link\]](#)
- Gpatindia. IPRATROPIUM BROMIDE Synthesis, SAR, MCQ, Structure, Chemical Properties and Therapeutic Uses. [Online] Available at: [\[Link\]](#)
- Cambridge University Press. Williamson Ether Synthesis. [Online] Available at: [\[Link\]](#)
- Williamson Ether Synthesis. Williamson Ether Synthesis. [Online] Available at: [\[Link\]](#)
- Chemistry Steps. Williamson Ether Synthesis. [Online] Available at: [\[Link\]](#)
- Master Organic Chemistry. The Williamson Ether Synthesis. [Online] Available at: [\[Link\]](#)
- Williamson Ether Synthesis. The Williamson Ether Synthesis. [Online] Available at: [\[Link\]](#)
- Aecenar. Phenylacetic acid production(PAA-precursor). [Online] Available at: [\[Link\]](#)
- PrepChem.com. Preparation of mandelic acid (2-hydroxy-2-phenylacetic acid). [Online] Available at: [\[Link\]](#)
- Google Patents. US4339594A - Process for the manufacture of phenylacetic acid and simple derivatives thereof.
- Organic Syntheses. Phenylacetic acid. [Online] Available at: [\[Link\]](#)
- Chemguide. Hydrolysing esters. [Online] Available at: [\[Link\]](#)
- Sciencemadness Discussion Board. Ester hydrolysis. [Online] Available at: [\[Link\]](#)
- Chemistry LibreTexts. 15.8: Hydrolysis of Esters. [Online] Available at: [\[Link\]](#)
- Journal of Pharmaceutical Sciences. Relative hydrolytic rates of certain alkyl (b) dl- α -(2-piperidyl)-phenylacetates. [Online] Available at: [\[Link\]](#)
- PubChem. Phenylacetic Acid | C₈H₈O₂ | CID 999. [Online] Available at: [\[Link\]](#)

- Google Patents. US20030013911A1 - Production method of 2-cyclohexyl- 2-hydroxy-2-phenylacetic acid intermediate therefor and production method thereof.
- Google Patents. EP0006539A1 - Process for the preparation of mandelic-acid esters.
- BMRB. bmse000220 Phenylacetic Acid. [Online] Available at: [\[Link\]](#)
- PubMed. Analysis of the infrared and Raman spectra of phenylacetic acid and mandelic (2-hydroxy-2-phenylacetic) acid. [Online] Available at: [\[Link\]](#)
- Organic Syntheses. Methyl isopropyl carbinol. [Online] Available at: [\[Link\]](#)
- ResearchGate. Analysis of the infrared and Raman spectra of phenylacetic acid and mandelic (2-hydroxy-2-phenylacetic) acid. [Online] Available at: [\[Link\]](#)
- NIST WebBook. Phenylacetic acid, 2-naphthyl ester. [Online] Available at: [\[Link\]](#)
- ResearchGate. EI mass spectra of phenylacetic acid. [Online] Available at: [\[Link\]](#)
- PubChem. 2-Phenylacetic acid;2-phenylacetonitrile | C16H15NO2 | CID 69404736. [Online] Available at: [\[Link\]](#)
- Semantic Scholar. Selective alkylation of m-cresol with isopropyl alcohol under solvent-free conditions. [Online] Available at: [\[Link\]](#)

Need Custom Synthesis?

BenchChem offers custom synthesis for rare earth carbides and specific isotopic labeling.

Email: info@benchchem.com or [Request Quote Online](#).

Sources

1. [researchgate.net](https://www.researchgate.net) [[researchgate.net](https://www.researchgate.net)]
2. [youtube.com](https://www.youtube.com) [[youtube.com](https://www.youtube.com)]
3. [IPRATROPIUM BROMIDE Synthesis, SAR, MCQ, Structure, Chemical Properties and Therapeutic Uses - Gpatindia: Pharmacy Jobs, Admissions, Scholarships, Conference, Grants, Exam Alerts](#) [[gpatindia.com](https://www.gpatindia.com)]

- [4. Williamson Ether Synthesis \(Chapter 116\) - Name Reactions in Organic Synthesis \[cambridge.org\]](#)
- [5. Williamson Ether Synthesis - Chemistry Steps \[chemistrysteps.com\]](#)
- [6. masterorganicchemistry.com \[masterorganicchemistry.com\]](#)
- [7. chemguide.co.uk \[chemguide.co.uk\]](#)
- [8. chem.libretexts.org \[chem.libretexts.org\]](#)
- [9. 2-Isopropyl-2-phenylacetic acid | 3508-94-9 \[chemicalbook.com\]](#)
- [10. researchgate.net \[researchgate.net\]](#)
- To cite this document: BenchChem. [Introduction: The Significance of a Versatile Phenylacetic Acid Derivative]. BenchChem, [2026]. [Online PDF]. Available at: [<https://www.benchchem.com/product/b1605838/docs#introduction-the-significance-of-a-versatile-phenylacetic-acid-derivative>]

Disclaimer & Data Validity:

The information provided in this document is for Research Use Only (RUO) and is strictly not intended for diagnostic or therapeutic procedures. While BenchChem strives to provide accurate protocols, we make no warranties, express or implied, regarding the fitness of this product for every specific experimental setup.

Technical Support: The protocols provided are for reference purposes. Unsure if this reagent suits your experiment?

Need Industrial/Bulk Grade? [Request Custom Synthesis Quote](#)

BenchChem

Our mission is to be the trusted global source of essential and advanced chemicals, empowering scientists and researchers to drive progress in science and industry.

Contact

Address: 3281 E Guasti Rd

Ontario, CA 91761, United States

Phone: (601) 213-4426

Email: info@benchchem.com

Contact our Ph.D. Support Team for a compatibility check