

Topic: Analytical Methods for the Quantification of 4-Isopropyl-2-methylphenol

Author: BenchChem Technical Support Team. **Date:** May 2026

Compound of Interest

Compound Name: 4-Isopropyl-2-methylphenol

CAS No.: 1740-97-2

Cat. No.: B1604796

[Get Quote](#)

**Abstract

This comprehensive application note provides detailed protocols for the accurate and robust quantification of **4-Isopropyl-2-methylphenol** (CAS 1740-97-2), a compound of interest in pharmaceutical, fragrance, and chemical industries.^{[1][2]} We present three validated analytical methodologies: High-Performance Liquid Chromatography with UV detection (HPLC-UV), Gas Chromatography-Mass Spectrometry (GC-MS), and a rapid screening method using UV-Vis Spectrophotometry. This guide is designed for researchers, scientists, and drug development professionals, offering not just step-by-step instructions but also the scientific rationale behind key procedural choices, ensuring methodological robustness and transferability.

Introduction: The Analyte in Focus

4-Isopropyl-2-methylphenol, also known as isothymol, is a phenolic compound whose precise quantification is critical for quality control, stability studies, and formulation development.^[1] Its structure, featuring a hydroxyl group attached to an aromatic ring, along with alkyl substituents, dictates its analytical behavior. The molecule possesses moderate

polarity and a distinct UV chromophore, making it amenable to several analytical techniques.[3]
[4]

Key Physicochemical Properties:

- Molecular Formula: $C_{10}H_{14}O$ [1]
- Molecular Weight: 150.22 g/mol [1]
- Boiling Point: ~506 K (233 °C)[5]
- LogP (Octanol/Water Partition Coefficient): 2.8 - 3.26[4][5]
- UV Absorbance: Exhibits UV absorbance due to the phenolic ring, suitable for UV-based detection.[1]

The choice of an analytical method is governed by the sample matrix, required sensitivity, and available instrumentation. This note will explore the primary chromatographic techniques, HPLC and GC, which provide the selectivity and sensitivity necessary for complex samples, alongside a simpler spectrophotometric method for high-throughput screening.

General Sample Preparation Workflow

Effective sample preparation is the cornerstone of accurate quantification. It aims to extract the analyte from the sample matrix, remove interfering substances, and present the analyte in a solvent compatible with the analytical instrument.[6]

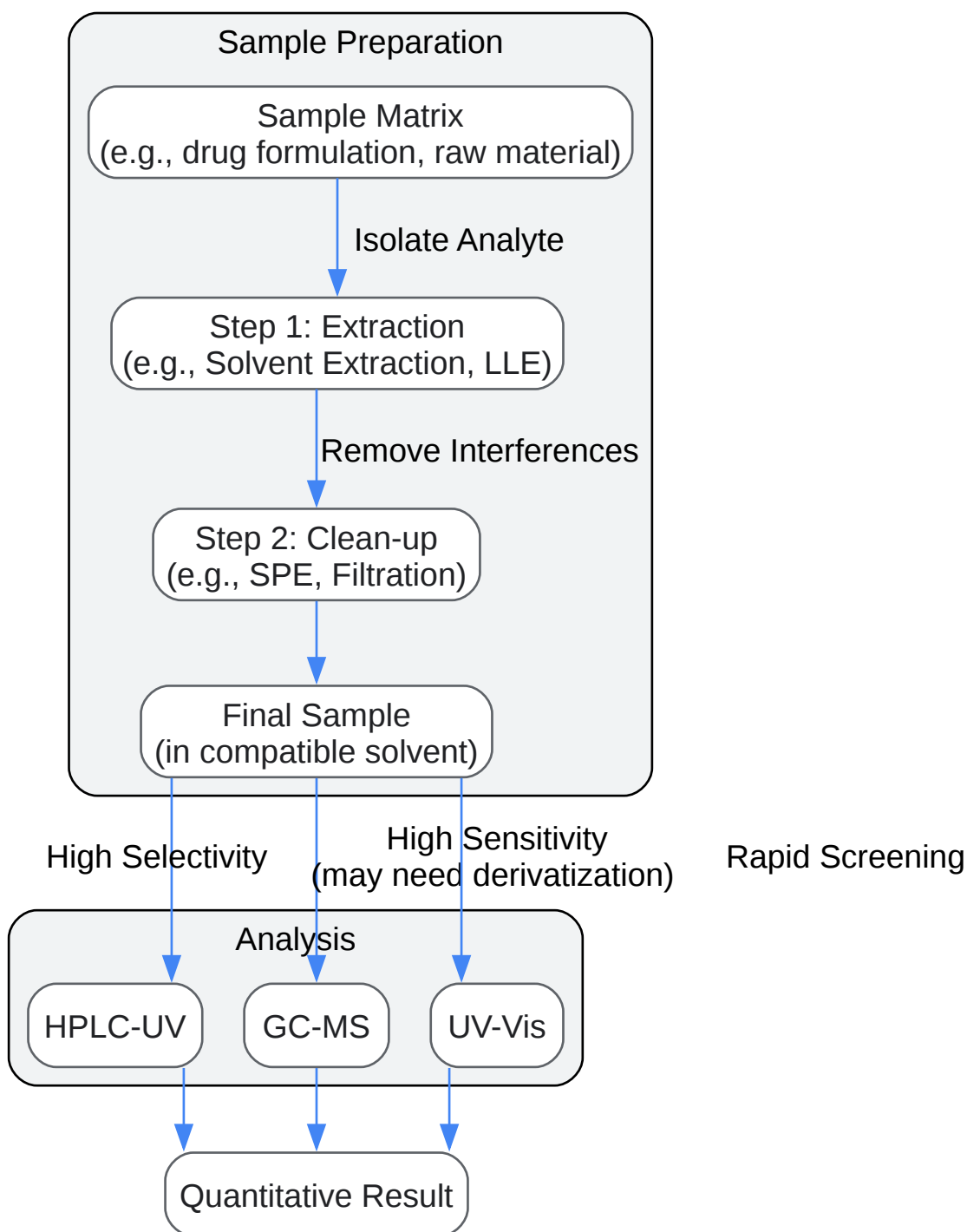

[Click to download full resolution via product page](#)

Caption: General workflow for **4-Isopropyl-2-methylphenol** quantification.

Protocol 1: General Solid Phase Extraction (SPE) for Complex Matrices

Solid Phase Extraction (SPE) is a highly effective technique for cleaning complex samples by leveraging differences in chemical properties between the analyte and matrix components.[7]

For **4-Isopropyl-2-methylphenol**, a reversed-phase (C18 or Phenyl) SPE cartridge is ideal.

Rationale: The non-polar C18 stationary phase retains the moderately non-polar analyte (LogP ~3) via hydrophobic interactions, while polar impurities are washed away. The analyte is then eluted with a stronger, non-polar organic solvent.

Step-by-Step Protocol:

- **Conditioning:** Pass 5 mL of methanol, followed by 5 mL of deionized water through a C18 SPE cartridge. This activates the stationary phase.
- **Loading:** Dissolve the sample in a polar solvent (e.g., water with a small percentage of organic solvent) and load it onto the cartridge at a slow flow rate (~1 mL/min).
- **Washing:** Wash the cartridge with 5 mL of a water/methanol mixture (e.g., 90:10 v/v) to remove polar interferences.
- **Elution:** Elute the **4-Isopropyl-2-methylphenol** with 5 mL of methanol or acetonitrile into a clean collection tube.
- **Final Preparation:** Evaporate the eluent to dryness under a gentle stream of nitrogen and reconstitute the residue in the mobile phase for HPLC analysis or a suitable solvent for GC analysis.

Method 1: High-Performance Liquid Chromatography with UV Detection (HPLC-UV)

HPLC is the premier method for the analysis of phenolic compounds due to its high resolution, sensitivity, and applicability to non-volatile compounds.[3][8] A reversed-phase method is most common.[9]

Principle of a Self-Validating System: The method's trustworthiness is established by including system suitability tests (e.g., peak symmetry, resolution) and validating key performance parameters. According to international guidelines, validation should demonstrate specificity, linearity, accuracy, precision, and sensitivity (LOD/LOQ).[10][11]

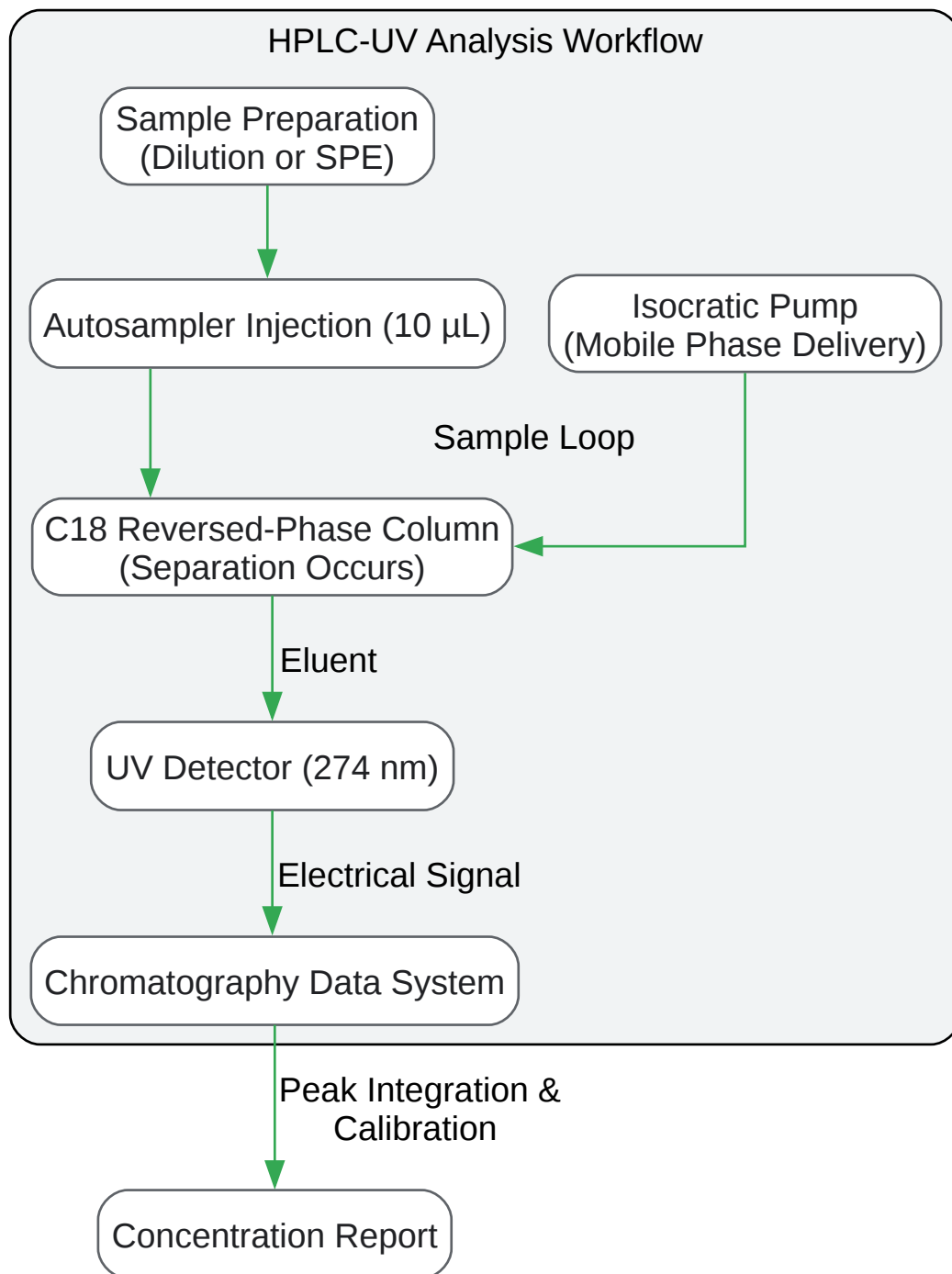

[Click to download full resolution via product page](#)

Caption: Experimental workflow for HPLC-UV analysis.

Protocol 2: HPLC-UV Quantification

Instrumentation and Consumables:

- HPLC system with UV/PDA detector
- C18 column (e.g., 4.6 x 150 mm, 5 μ m particle size)
- Acetonitrile (HPLC grade)
- Water (HPLC grade)
- Phosphoric acid or Formic acid[9]

Chromatographic Conditions:

- Mobile Phase: Acetonitrile : Water (60:40 v/v) with 0.1% phosphoric acid. Rationale: The organic modifier (acetonitrile) controls retention on the C18 column. The acidic pH suppresses the ionization of the phenolic hydroxyl group, ensuring a single, well-retained peak with good symmetry.[12]
- Flow Rate: 1.0 mL/min
- Column Temperature: 30 °C
- Injection Volume: 10 μ L
- Detection Wavelength: 274 nm. Rationale: This wavelength is chosen based on the UV absorbance maximum for phenolic compounds, providing high sensitivity.[13]

Procedure:

- Standard Preparation: Prepare a stock solution of **4-Isopropyl-2-methylphenol** (1 mg/mL) in the mobile phase. Perform serial dilutions to create calibration standards ranging from 1 μ g/mL to 100 μ g/mL.

- **Sample Preparation:** Prepare the sample using dilution or the SPE protocol described above, ensuring the final solvent is the mobile phase.
- **System Equilibration:** Equilibrate the HPLC system with the mobile phase until a stable baseline is achieved.
- **Calibration Curve:** Inject the calibration standards in triplicate. Plot the mean peak area against the concentration and perform a linear regression. The correlation coefficient (R^2) should be >0.999 for good linearity.[11]
- **Sample Analysis:** Inject the prepared samples.
- **Quantification:** Determine the concentration of **4-Isopropyl-2-methylphenol** in the samples by interpolating their peak areas from the calibration curve.

Method 2: Gas Chromatography-Mass Spectrometry (GC-MS)

GC-MS is an exceptionally sensitive and specific technique ideal for volatile and semi-volatile compounds.[14] While **4-Isopropyl-2-methylphenol** is sufficiently volatile for GC, its polar hydroxyl group can cause peak tailing on standard non-polar columns. Derivatization can mitigate this issue.[14]

Principle of Derivatization: A chemical modification (e.g., silylation) is used to replace the active hydrogen of the hydroxyl group with a non-polar group (e.g., trimethylsilyl, TMS). This increases volatility and thermal stability, resulting in sharper, more symmetrical peaks and improved sensitivity.

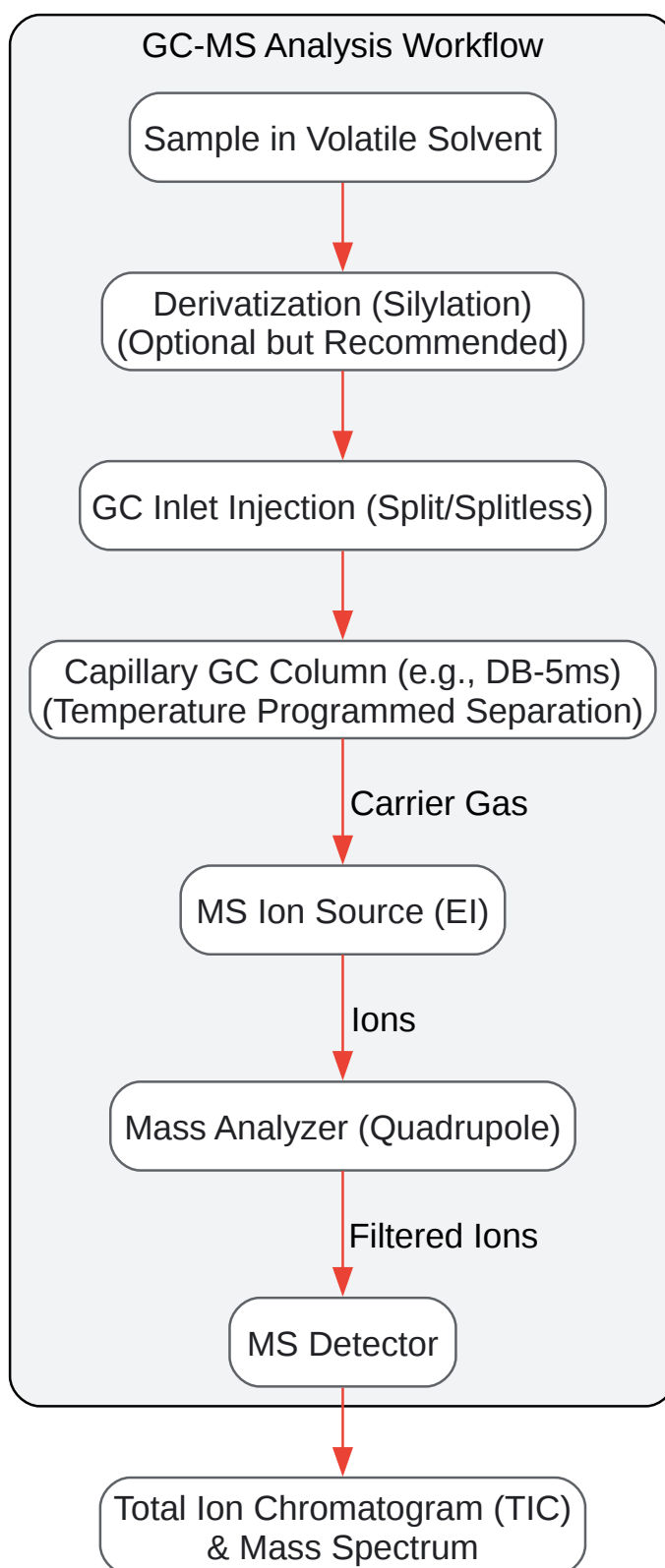

[Click to download full resolution via product page](#)

Caption: Experimental workflow for GC-MS analysis.

Protocol 3: GC-MS Quantification

Instrumentation and Consumables:

- GC-MS system with an autosampler
- Capillary column (e.g., 30 m x 0.25 mm ID, 0.25 μm film thickness, 5% phenyl-methylpolysiloxane)
- Helium (carrier gas)
- Derivatizing agent (e.g., BSTFA with 1% TMCS)
- Anhydrous pyridine or other suitable solvent

GC-MS Conditions:

- Inlet Temperature: 250 $^{\circ}\text{C}$
- Injection Mode: Splitless (1 μL injection volume)
- Carrier Gas: Helium at a constant flow of 1.2 mL/min
- Oven Program:
 - Initial temperature: 80 $^{\circ}\text{C}$, hold for 2 minutes
 - Ramp: 10 $^{\circ}\text{C}/\text{min}$ to 250 $^{\circ}\text{C}$
 - Hold: 5 minutes at 250 $^{\circ}\text{C}$
- MS Transfer Line: 280 $^{\circ}\text{C}$
- Ion Source Temperature: 230 $^{\circ}\text{C}$
- Ionization Mode: Electron Ionization (EI) at 70 eV
- Acquisition Mode: Scan (m/z 40-300) for identification and Selected Ion Monitoring (SIM) for quantification. Rationale: SIM mode enhances sensitivity and selectivity by monitoring only

characteristic ions of the analyte.

Procedure:

- Derivatization: a. Place 100 μL of the sample (in a volatile solvent like hexane) into a vial. b. Add 50 μL of BSTFA + 1% TMCS. c. Cap the vial tightly and heat at 70 $^{\circ}\text{C}$ for 30 minutes. d. Cool to room temperature before injection.
- Standard and Sample Analysis: Prepare calibration standards and samples using the same derivatization procedure.
- Analysis: Inject the derivatized standards and samples into the GC-MS.
- Quantification: Identify the analyte by its retention time and mass spectrum. For quantification in SIM mode, use the area of the most abundant, characteristic ion. Construct a calibration curve as described for the HPLC method.

Method 3: UV-Vis Spectrophotometry (Screening)

For simple, clean sample matrices where **4-Isopropyl-2-methylphenol** is the primary absorbing species, UV-Vis spectrophotometry offers a rapid, cost-effective method for quantification.^[15]

Principle: This method relies on the Beer-Lambert Law, which states that the absorbance of a solution is directly proportional to the concentration of the absorbing species.

Protocol 4: UV-Vis Spectrophotometric Quantification

Instrumentation and Consumables:

- UV-Vis Spectrophotometer
- Quartz cuvettes (1 cm path length)
- Ethanol or Methanol (UV grade)

Procedure:

- Determine λ_{max} : Scan a standard solution of **4-Isopropyl-2-methylphenol** (e.g., 10 $\mu\text{g/mL}$ in ethanol) from 200 to 400 nm to find the wavelength of maximum absorbance (λ_{max}), which is expected around 274-280 nm.
- Standard Preparation: Prepare a stock solution and a series of calibration standards (e.g., 1, 2, 5, 10, 15 $\mu\text{g/mL}$) in the chosen solvent.
- Calibration Curve: a. Zero the spectrophotometer using the pure solvent as a blank. b. Measure the absorbance of each calibration standard at λ_{max} . c. Plot absorbance vs. concentration to create a calibration curve.
- Sample Analysis: Dilute the sample appropriately with the solvent to ensure its absorbance falls within the linear range of the calibration curve. Measure its absorbance.
- Quantification: Calculate the concentration using the linear regression equation from the calibration curve.

Comparison of Analytical Methods

The selection of the most appropriate method depends on the specific analytical challenge.

Parameter	HPLC-UV	GC-MS	UV-Vis Spectrophotometry
Selectivity	High	Very High	Low
Sensitivity (Typical LOQ)	~0.1 - 0.5 µg/mL[11]	~0.01 - 0.1 ng/mL (SIM mode)[16][17]	~1 µg/mL
Sample Throughput	Moderate	Moderate to Low	High
Derivatization Required	No	Recommended	No
Matrix Tolerance	Good	Good (with clean-up)	Poor
Cost (Instrument/Run)	Moderate	High	Low
Primary Application	Routine QC, formulation analysis	Trace analysis, impurity profiling, confirmatory analysis	Rapid screening of simple mixtures

Conclusion

This application note details three robust methods for the quantification of **4-Isopropyl-2-methylphenol**.

- HPLC-UV stands out as the most versatile and widely applicable method for routine quality control in pharmaceutical and industrial settings.[9]
- GC-MS offers unparalleled sensitivity and specificity, making it the method of choice for trace-level detection, impurity identification, and as a definitive confirmatory technique.[16][18]
- UV-Vis Spectrophotometry serves as a valuable tool for rapid, high-throughput screening when sample complexity is low.

Each protocol is designed to be self-validating, but it is imperative that laboratories perform their own method validation to ensure the results are fit for their intended purpose.[10][19]

References

- Lee, J. H., et al. (2023). Development of an analytical method to determine methyl alcohol and isopropyl alcohol in food using static headspace gas chromatography. Food Science and Biotechnology. Available at: [\[Link\]](#)
- Krcmová, L., et al. (2009). Validation of the analytical method for the determination of flavonoids in broccoli. ACTA ALIMENTARIA. Available at: [\[Link\]](#)
- Khoddami, A., et al. (2013). Techniques for Analysis of Plant Phenolic Compounds. Molecules. Available at: [\[Link\]](#)
- U.S. Environmental Protection Agency. (1986). Method for the determination of phenol and methylphenols (cresols) in ambient air using HPLC. EPA. Available at: [\[Link\]](#)
- Phenomenex. (n.d.). Reversed Phase HPLC Method Development. Phenomenex. Available at: [\[Link\]](#)
- Horvat, K., et al. (2019). Development of HPLC method for determination of phenolic compounds on a core shell column by direct injection of wine samples. ACTA ALIMENTARIA. Available at: [\[Link\]](#)
- Leston, G. (1984). Process for preparation of 4-isopropylphenol. Google Patents.
- European Patent Office. (2023). Preparation method for (4-isopropoxy-2-methyl) phenyl isopropyl ketone. EPO. Available at: [\[Link\]](#)
- International Organisation of Vine and Wine. (n.d.). Determination of alkylphenols in wines by gas chromatography-mass spectrometry (GC-MS or GC-MS/MS). OIV. Available at: [\[Link\]](#)
- ResearchGate. (n.d.). UV-Vis spectra of pure IPA and PVP in IPA at different concentrations. ResearchGate. Available at: [\[Link\]](#)
- European Patent Office. (2019). Method for producing 4-isopropyl-3-methylphenol. EPO. Available at: [\[Link\]](#)
- National Center for Biotechnology Information. (2024). 2-Isopropyl-p-cresol. PubChem Compound Database. Available at: [\[Link\]](#)

- SIELC Technologies. (2018). 2-Isopropyl-4-methylphenol. SIELC Technologies. Available at: [\[Link\]](#)
- Cheméo. (n.d.). Chemical Properties of **4-Isopropyl-2-methylphenol** (CAS 1740-97-2). Cheméo. Available at: [\[Link\]](#)
- SIELC Technologies. (2018). Separation of 2-Isopropyl-4-methylphenol on Newcrom R1 HPLC column. SIELC Technologies. Available at: [\[Link\]](#)
- Jo, A., et al. (2024). Development and validation of analytical HPLC for phenolics in Pinus densiflora bark extract. Food Science and Biotechnology. Available at: [\[Link\]](#)
- Salar, A., et al. (2024). Validation of Microplate Methods for Total Phenolic Content and Antioxidant Activity on Honeys, and Comparison with Conventional Spectrophotometric Methods. Applied Sciences. Available at: [\[Link\]](#)
- Lee, J. H., et al. (2023). Development of an analytical method to determine methyl alcohol and isopropyl alcohol in food using static headspace gas chromatography. PubMed. Available at: [\[Link\]](#)
- Agilent Technologies. (n.d.). Sample Preparation Fundamentals for Chromatography. Agilent. Available at: [\[Link\]](#)

Need Custom Synthesis?

BenchChem offers custom synthesis for rare earth carbides and specific isotopic labeling.

Email: info@benchchem.com or [Request Quote Online](#).

Sources

- 1. 2-Isopropyl-p-cresol | C₁₀H₁₄O | CID 78153 - PubChem [pubchem.ncbi.nlm.nih.gov]
- 2. 4-Isopropyl-2-methylphenol | [frontierspecialtychemicals.com]
- 3. mdpi.com [mdpi.com]
- 4. 2-Isopropyl-4-methylphenol | SIELC Technologies [sielc.com]

- [5. 4-Isopropyl-2-methylphenol \(CAS 1740-97-2\) - Chemical & Physical Properties by Cheméo \[chemeo.com\]](#)
- [6. agilent.com \[agilent.com\]](#)
- [7. documents.thermofisher.com \[documents.thermofisher.com\]](#)
- [8. akjournals.com \[akjournals.com\]](#)
- [9. Separation of 2-Isopropyl-4-methylphenol on Newcrom R1 HPLC column | SIELC Technologies \[sielc.com\]](#)
- [10. inhort.pl \[inhort.pl\]](#)
- [11. Development and validation of analytical HPLC for phenolics in Pinus densiflora bark extract - PMC \[pmc.ncbi.nlm.nih.gov\]](#)
- [12. phx.phenomenex.com \[phx.phenomenex.com\]](#)
- [13. epa.gov \[epa.gov\]](#)
- [14. benchchem.com \[benchchem.com\]](#)
- [15. researchgate.net \[researchgate.net\]](#)
- [16. Development of an analytical method to determine methyl alcohol and isopropyl alcohol in food using static headspace gas chromatography - PMC \[pmc.ncbi.nlm.nih.gov\]](#)
- [17. Development of an analytical method to determine methyl alcohol and isopropyl alcohol in food using static headspace gas chromatography - PubMed \[pubmed.ncbi.nlm.nih.gov\]](#)
- [18. Determination of alkylphenols in wines by gas chromatography-mass spectrometry \(GC-MS or GC-MS/MS\) \(Type-IV\) | OIV \[oiv.int\]](#)
- [19. mdpi.com \[mdpi.com\]](#)
- [To cite this document: BenchChem. \[Topic: Analytical Methods for the Quantification of 4-Isopropyl-2-methylphenol\]. BenchChem, \[2026\]. \[Online PDF\]. Available at: \[https://www.benchchem.com/product/b1604796/docs#topic-analytical-methods-for-the-quantification-of-4-isopropyl-2-methylphenol\]](#)

Disclaimer & Data Validity:

The information provided in this document is for Research Use Only (RUO) and is strictly not intended for diagnostic or therapeutic procedures. While BenchChem strives to provide accurate protocols, we make no warranties, express or implied, regarding the fitness of this product for every specific experimental setup.

Technical Support: The protocols provided are for reference purposes. Unsure if this reagent suits your experiment?

Need Industrial/Bulk Grade? [Request Custom Synthesis Quote](#)

BenchChem

Our mission is to be the trusted global source of essential and advanced chemicals, empowering scientists and researchers to drive progress in science and industry.

Contact

Address: 3281 E Guasti Rd
Ontario, CA 91761, United States
Phone: (601) 213-4426
Email: info@benchchem.com

[Contact our Ph.D. Support Team for a compatibility check](#)