

Comparative Guide: Mass Spectrometry Profiling of 2-(4-Isocyanatophenyl)pyrimidine

Author: BenchChem Technical Support Team. **Date:** April 2026

Compound of Interest

Compound Name: 2-(4-Isocyanatophenyl)pyrimidine

CAS No.: 216059-84-6

Cat. No.: B1604172

[Get Quote](#)

Executive Summary & Application Context

2-(4-Isocyanatophenyl)pyrimidine (CAS: 216059-84-6, MW: 197.20) is a bifunctional heterocyclic building block. It combines the electrophilic reactivity of an isocyanate (-N=C=O) with the proton-affinity of a pyrimidine ring.

In drug development, this compound serves two primary roles:

- **Synthetic Intermediate:** A precursor for urea/carbamate-based kinase inhibitors.
- **Analytical Derivatization Reagent:** A "tagging" agent for amines/alcohols in LC-MS. Unlike the standard Phenyl Isocyanate, the pyrimidine moiety enhances ionization efficiency in ESI (+) mode due to its basic nitrogen atoms, making it a superior alternative for trace analysis of nucleophiles.

Fragmentation Mechanics: The "Why" and "How"

The fragmentation behavior of **2-(4-Isocyanatophenyl)pyrimidine** is distinct depending on the ionization method. Understanding these pathways is critical for distinguishing this specific

isomer from other nitrogenous heterocycles.

A. Electron Impact (EI) Fragmentation (70 eV)

Hard Ionization | Radical Driven

In EI, the molecular ion (

, m/z 197) is generated. The fragmentation is driven by the stability of the aromatic system and the lability of the isocyanate group.

- Primary Pathway (Isocyanate Collapse): The most diagnostic loss is carbon monoxide (CO, 28 Da), generating a nitrene-like radical cation (m/z 169).
- Secondary Pathway (Linker Cleavage): Loss of the entire isocyanate radical (NCO, 42 Da) yields the 2-phenylpyrimidine cation (m/z 155).
- Tertiary Pathway (Ring Degradation): The pyrimidine ring characteristically loses Hydrogen Cyanide (HCN, 27 Da), a "fingerprint" fragmentation for this heterocycle.

B. Electrospray Ionization (ESI-CID) Fragmentation

Soft Ionization | Proton Driven

In LC-MS/MS, the molecule forms an even-electron protonated species

(m/z 198).

- Protonation Site: The most basic site is the N1/N3 of the pyrimidine ring, not the isocyanate. This localizes the charge on the ring, stabilizing the parent ion.
- Collision Induced Dissociation (CID):
 - Low CE (10-20 eV): The molecule is relatively stable due to resonance.
 - High CE (>30 eV): Cleavage of the isocyanate moiety occurs. If derivatized (e.g., as a urea), the "Reporter Ion" (m/z 198 or its fragment m/z 156) often dominates, allowing for Precursor Ion Scanning.

Comparative Analysis: Performance vs. Alternatives

The table below contrasts **2-(4-Isocyanatophenyl)pyrimidine** with its standard alternative, Phenyl Isocyanate, highlighting why the pyrimidine analog is often preferred for sensitive bioanalysis.

Feature	Phenyl Isocyanate (Standard)	2-(4-Isocyanatophenyl)pyrimidine (Advanced)
MW / Parent Ion	119.12 Da / m/z 119	197.20 Da / m/z 197
ESI Ionization Efficiency	Low (Lacks basic site)	High (Pyrimidine N acts as proton trap)
Diagnostic Neutral Loss	43 Da (HNCO)	43 Da (HNCO) + 27 Da (HCN)
Major Fragment (EI)	m/z 91 (C H N)	m/z 155 (Phenyl-Pyrimidine)
Selectivity	Low (Common mass fragments)	High (Distinctive high-mass reporter)
Application	Bulk synthesis	Trace metabolite tagging / Kinase inhibitor synthesis

Visualized Fragmentation Pathways[2][3][4][5]

The following diagrams illustrate the mechanistic pathways for both EI (structural confirmation) and ESI (derivative analysis).

Diagram 1: Electron Impact (EI) Radical Pathway

This pathway is used for purity analysis and library matching.

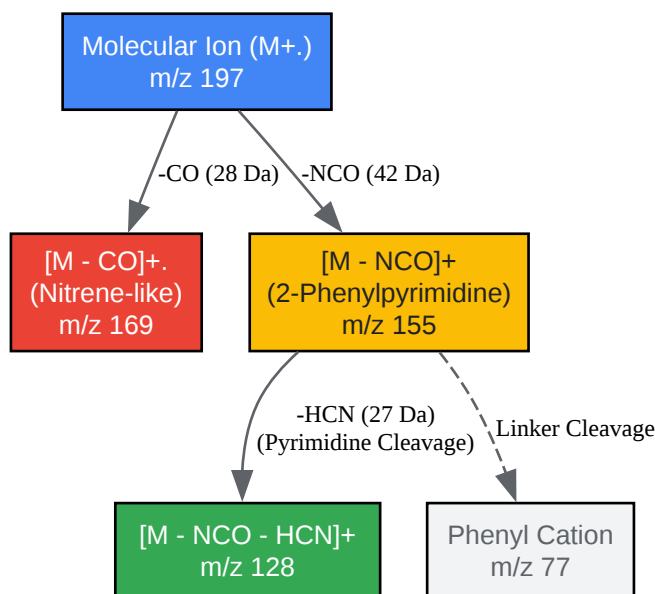

[Click to download full resolution via product page](#)

Caption: EI fragmentation starts with isocyanate degradation (-CO, -NCO) followed by pyrimidine ring opening (-HCN).

Diagram 2: ESI-CID Fragmentation of a Urea Derivative

This pathway represents the analysis of a drug molecule tagged with this reagent.

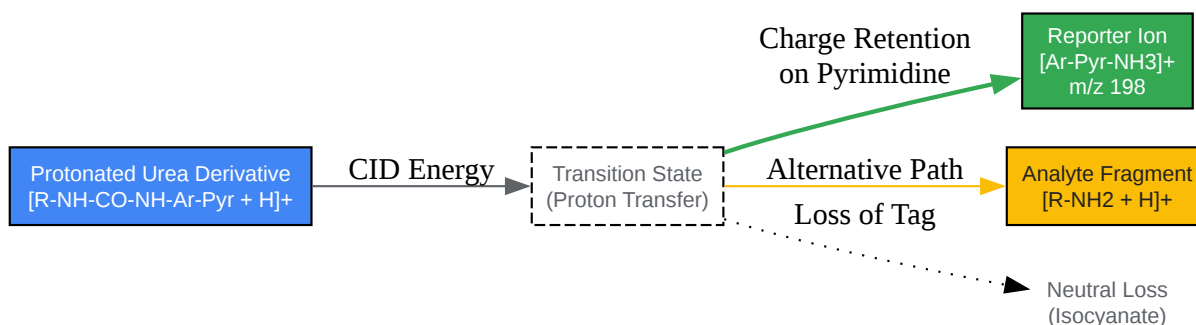

[Click to download full resolution via product page](#)

Caption: In ESI, the pyrimidine tag often retains the charge, generating a specific "Reporter Ion" (m/z 198) useful for tracking.

Experimental Protocols

Protocol A: EI-GC/MS for Purity Verification

Use this protocol to verify the integrity of the reagent before synthesis.

- Sample Prep: Dissolve 1 mg of **2-(4-Isocyanatophenyl)pyrimidine** in 1 mL of anhydrous Dichloromethane (DCM). Note: Avoid alcohols to prevent carbamate formation.
- Inlet: Splitless mode, 250°C.
- Column: DB-5ms or equivalent (30m x 0.25mm).
- Oven: 50°C (1 min) → 20°C/min → 300°C.
- MS Source: 70 eV, Source Temp 230°C.
- Validation: Check for parent ion m/z 197. If m/z 213 is observed, the sample has oxidized. If m/z 229 (methanol adduct) is seen, the solvent was wet.

Protocol B: ESI-LC/MS/MS for Derivative Analysis

Use this protocol when using the compound to tag amine-containing analytes.

- Derivatization: Mix analyte (amine) with 5-fold excess of reagent in Acetonitrile at 60°C for 30 mins.
- Mobile Phase: A: 0.1% Formic Acid in Water; B: 0.1% Formic Acid in Acetonitrile.
- Gradient: 5% B to 95% B over 10 mins.
- MS Settings: Positive Mode (+). Capillary Voltage 3.5 kV.
- Targeted Scan: Perform a Precursor Ion Scan for m/z 198 (the protonated amine-tag fragment) to selectively detect all tagged metabolites.

Data Summary: Diagnostic Ions

Ion Type	m/z (Theoretical)	Origin / Structure	Interpretation
	198.07	Protonated Molecule	Parent Peak (ESI)
	197.06	Molecular Ion	Parent Peak (EI)
	169.06	Nitrene Radical	Diagnostic for Isocyanates
	155.06	Phenyl-Pyrimidine	Linker Cleavage Base Peak
	128.05	Phenyl-Pyridyne-like	Pyrimidine Ring Opening
	77.04	Phenyl Cation	General Aromatic Indicator

References

- Fisher Scientific. (n.d.). **2-(4-Isocyanatophenyl)pyrimidine** Product Specifications & CAS 216059-84-6. Retrieved from [\[Link\]](#)
- Chemistry LibreTexts. (2023). Mass Spectrometry Fragmentation Patterns: Isocyanates and Aromatics. Retrieved from [\[Link\]](#)
- National Institutes of Health (NIH). (2021). Synthesis and characterization of urea derivatives by ESI-MS/MS. Retrieved from [\[Link\]](#)
- ChemGuide. (n.d.). Fragmentation Patterns in Mass Spectra of Organic Compounds. Retrieved from [\[Link\]](#)
- To cite this document: BenchChem. [\[Comparative Guide: Mass Spectrometry Profiling of 2-\(4-Isocyanatophenyl\)pyrimidine\]](#). BenchChem, [2026]. [\[Online PDF\]](#). Available at: [\[https://www.benchchem.com/product/b1604172/docs#comparative-guide-mass-spectrometry-profiling-of-2-4-isocyanatophenyl-pyrimidine\]](https://www.benchchem.com/product/b1604172/docs#comparative-guide-mass-spectrometry-profiling-of-2-4-isocyanatophenyl-pyrimidine)

Disclaimer & Data Validity:

The information provided in this document is for Research Use Only (RUO) and is strictly not intended for diagnostic or therapeutic procedures. While BenchChem strives to provide accurate protocols, we make no warranties, express or implied, regarding the fitness of this product for every specific experimental setup.

Technical Support: The protocols provided are for reference purposes. Unsure if this reagent suits your experiment?

Need Industrial/Bulk Grade? [Request Custom Synthesis Quote](#)

BenchChem

Our mission is to be the trusted global source of essential and advanced chemicals, empowering scientists and researchers to drive progress in science and industry.

Contact

Address: 3281 E Guasti Rd
Ontario, CA 91761, United States
Phone: (601) 213-4426
Email: info@benchchem.com

[Contact our Ph.D. Support Team for a compatibility check](#)