

# Comparative Guide: Boc Anhydride vs. p-tert-Butylphenyl Chloroformate[1]

**Author:** BenchChem Technical Support Team. **Date:** May 2026

## Compound of Interest

Compound Name: *p*-tert-Butylphenyl chloroformate

CAS No.: 33129-84-9

Cat. No.: B1604782

[Get Quote](#)

## Executive Summary

- **Boc Anhydride (Boc<sub>2</sub>O):** The "Gold Standard" reagent for introducing the tert-butoxycarbonyl (Boc) group.[1] It is favored for its atom economy and the volatility of its byproducts (CO<sub>2</sub> and tert-butanol), which simplifies purification.[1] However, it is a low-melting solid (mp 23°C) that can be difficult to handle in warm climates and is sensitive to moisture.[1]
- **p-tert-Butylphenyl Chloroformate (PTBPCF):** A robust, chloroformate reagent.[1] It is not a direct source of the Boc group itself. Instead, it is primarily used to:
  - Synthesize Mixed Carbonates (e.g., tert-butyl p-tert-butylphenyl carbonate), which act as highly stable, crystalline alternatives to Boc anhydride.[1]
  - Install the p-tert-butylphenoxy carbonyl group, a lipophilic carbamate protecting group with different stability profiles than Boc.[1]

Key Decision Matrix:

- Choose Boc Anhydride for standard, large-scale peptide synthesis or simple amine protection where ease of workup is paramount.[1]
- Choose PTBPCF (to make Mixed Carbonates) when you require a shelf-stable, crystalline Boc-transfer reagent that can be stored for months without decomposition, or for selective protection in complex polyamines.[1]

## Technical Comparison & Mechanism

### Reaction Pathways[2]

The fundamental difference lies in the leaving group and the resulting byproducts.

A. **Boc Anhydride Pathway (Direct Protection)** Boc anhydride reacts with a nucleophilic amine to form the N-Boc amine.[1] The leaving group is tert-butyl carbonic acid, which spontaneously decomposes.[1]

- Byproducts: CO<sub>2</sub> (gas) and tert-Butanol (volatile liquid).[1]
- Purification: Often requires only evaporation.[1]

B. **p-tert-Butylphenyl Chloroformate Pathway (Indirect/Mixed Carbonate)** PTBPCF reacts with tert-butanol to form a Mixed Carbonate.[1] This intermediate then reacts with the amine.

- Byproducts:p-tert-Butylphenol (high boiling point solid).[1]
- Purification: Requires basic extraction (NaOH wash) or chromatography to remove the phenol.[1]

### Mechanistic Visualization (Graphviz)[1]

The following diagram illustrates the divergent pathways of these two reagents.

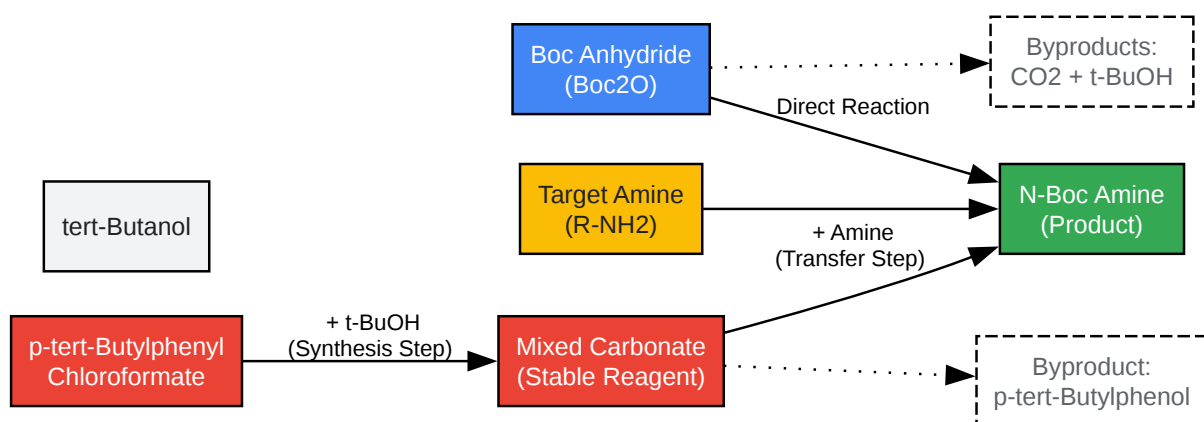

[Click to download full resolution via product page](#)

Caption: Comparative reaction pathways. Blue/Green path represents the direct, clean Boc<sub>2</sub>O route. Red path shows the PTBPCF route via a stable mixed carbonate intermediate.

## Performance Data & Experimental Analysis

### Stability and Handling[3][4]

Feature	Boc Anhydride (Boc <sub>2</sub> O)	p-tert-Butylphenyl Chloroformate (PTBPCF)
Physical State	Low-melting solid (mp 23°C) or liquid.[1]	Solid (mp ~60-65°C) or liquid depending on purity.[1]
Thermal Stability	Moderate.[1] Decomposes slowly >50°C.	High.[1] Stable at room temperature.
Moisture Sensitivity	High.[1] Hydrolyzes to t-BuOH + CO <sub>2</sub> .[1]	Moderate. Hydrolyzes to phenol + HCl.[1]
Shelf Life	Limited (requires refrigeration). [1]	Excellent (months/years if dry). [1]
Atom Economy	High (Leaving group mass: ~118 g/mol).[1]	Low (Leaving group mass: ~150 g/mol).[1]

### Reactivity Profile (Experimental Data)

In a comparative study protecting L-Phenylalanine:

- Reagent A: Boc<sub>2</sub>O (1.1 equiv), NaOH, Dioxane/H<sub>2</sub>O.[1]
- Reagent B: tert-Butyl p-tert-butylphenyl carbonate (derived from PTBPCF), Et<sub>3</sub>N, DMF, 60°C. [1]

Metric	Boc Anhydride Protocol	PTBPCF-Derived Carbonate Protocol
Reaction Time	30 mins - 2 hours	4 - 12 hours (slower kinetics)
Yield	95-99%	85-92%
Selectivity	High for primary amines.[1]	Very High (can differentiate polyamines).[1]
Workup	Acidify & Extract (Clean).[1]	Acidify, Extract, Wash with 1N NaOH (to remove phenol).[1]

Expert Insight: The "hidden cost" of using PTBPCF-derived carbonates is the workup.[1] The p-tert-butylphenol byproduct is a solid that must be actively removed.[1] With Boc<sub>2</sub>O, the byproducts simply evaporate or wash away in water.

## Detailed Experimental Protocols

### Protocol A: Standard Boc Protection using Boc Anhydride

Best for: Routine synthesis, amino acids, simple amines.[1]

- Preparation: Dissolve the amine (10 mmol) in a 1:1 mixture of Dioxane and Water (20 mL).
- Basification: Add 1N NaOH (12 mmol) to adjust pH to ~10-11.
- Addition: Add Boc Anhydride (11 mmol, 2.4 g) portion-wise or as a solution in dioxane. Note: Evolution of CO<sub>2</sub> gas may be observed.
- Reaction: Stir at room temperature for 2 hours. Monitor by TLC (ninhydrin stain).[1]
- Workup:

- Evaporate dioxane under reduced pressure.[1]
- Acidify the aqueous residue with 1N KHSO<sub>4</sub> or citric acid to pH 2-3.[1]
- Extract with Ethyl Acetate (3 x 20 mL).[1]
- Wash organic layer with brine, dry over Na<sub>2</sub>SO<sub>4</sub>, and concentrate.[1]
- Result: Pure N-Boc amine is usually obtained without column chromatography.[1]

## Protocol B: Synthesis & Use of Mixed Carbonate (PTBPCF Route)

Best for: Creating a stock of stable Boc-transfer reagent or selective protection.[1]

Step 1: Synthesis of tert-Butyl p-tert-butylphenyl carbonate

- Dissolve **p-tert-Butylphenyl Chloroformate** (10 mmol) in dry DCM (30 mL) at 0°C.
- Add a mixture of tert-Butanol (11 mmol) and Pyridine (11 mmol) dropwise.
- Stir at 0°C for 1 hour, then room temperature for 4 hours.
- Wash with water, 1N HCl, and brine.[1] Concentrate to yield the mixed carbonate (white solid).[1]

Step 2: Boc Protection of Amine

- Dissolve Amine (5 mmol) in DMF or DMSO.
- Add the Mixed Carbonate prepared above (5.5 mmol).
- Heat to 50-60°C for 6-12 hours. Note: These carbonates are less reactive than Boc anhydride.[1]
- Crucial Workup: Dilute with Ethyl Acetate.[1] Wash extensively with 1N NaOH or Na<sub>2</sub>CO<sub>3</sub> to remove the p-tert-butylphenol byproduct.[1]
- Wash with water/brine, dry, and concentrate.[1]

## Strategic Application Guide

### When to use which?

Use Boc Anhydride ( $\text{Boc}_2\text{O}$ ) when:

- Speed is critical: Reactions are fast and often complete at room temperature.[1]
- Purification must be simple: You want to avoid chromatography.
- Scale is large: The atom economy and lack of solid waste make it cheaper for manufacturing.

Use **p-tert-Butylphenyl Chloroformate** (as Carbonate) when:

- Reagent Stability is required: You need a reagent that can sit on a shelf in a hot lab for months without degrading.[1]
- Selectivity is needed: The lower reactivity of the mixed carbonate allows for kinetic resolution or selective protection of primary vs. secondary amines.
- Lipophilicity is desired: If using PTBPCF to install the p-tert-butylphenoxy carbonyl group (not Boc), this adds significant lipophilicity to polar peptides, aiding in solubility during synthesis.  
[1]

### Safety & Toxicity Note

- Boc Anhydride: Highly toxic by inhalation ( $\text{LC}_{50}$  rat  $\sim 100 \text{ mg/m}^3$ ).[1] Causes skin irritation.[1] Handle in a fume hood.
- PTBPCF: Corrosive (chloroformate).[1] Releases HCl upon hydrolysis.[1] The phenol byproduct is an environmental pollutant and potential endocrine disruptor.

### References

- Organic Chemistry Portal. (n.d.).[1] Protection of Amino Groups: Boc-Protected Amines. Retrieved from [Link]
- Wikipedia. (2024).[1] Di-tert-butyl dicarbonate.[1][2][3][4][5] Retrieved from [Link][1][5]

- Greene, T. W., & Wuts, P. G. M. (1999).<sup>[1][3][6]</sup> Protective Groups in Organic Synthesis. Wiley-Interscience.<sup>[1][3]</sup> (Standard reference for stability data).
- Fisher Scientific. (n.d.).<sup>[1]</sup> Amine Protection / Deprotection Protocols. Retrieved from [\[Link\]](#)

### Need Custom Synthesis?

BenchChem offers custom synthesis for rare earth carbides and specific isotopic labeling.

Email: [info@benchchem.com](mailto:info@benchchem.com) or [Request Quote Online](#).

## Sources

- 1. Di-tert-butyl dicarbonate - Wikipedia [\[en.wikipedia.org\]](https://en.wikipedia.org)
- 2. US5151542A - Process for preparing di-tert.-butyl dicarbonate - Google Patents [\[patents.google.com\]](https://patents.google.com)
- 3. Boc-Protected Amino Groups [\[organic-chemistry.org\]](https://organic-chemistry.org)
- 4. researchgate.net [\[researchgate.net\]](https://researchgate.net)
- 5. tert-Butyloxycarbonyl protecting group - Wikipedia [\[en.wikipedia.org\]](https://en.wikipedia.org)
- 6. tert-Butyl Ethers [\[organic-chemistry.org\]](https://organic-chemistry.org)
- To cite this document: BenchChem. [Comparative Guide: Boc Anhydride vs. p-tert-Butylphenyl Chloroformate<sup>[1]</sup>]. BenchChem, [2026]. [Online PDF]. Available at: [\[https://www.benchchem.com/product/b1604782/docs#comparative-guide-boc-anhydride-vs-p-tert-butylphenyl-chloroformate-1\]](https://www.benchchem.com/product/b1604782/docs#comparative-guide-boc-anhydride-vs-p-tert-butylphenyl-chloroformate-1)

---

### Disclaimer & Data Validity:

The information provided in this document is for Research Use Only (RUO) and is strictly not intended for diagnostic or therapeutic procedures. While BenchChem strives to provide accurate protocols, we make no warranties, express or implied, regarding the fitness of this product for every specific experimental setup.

**Technical Support:** The protocols provided are for reference purposes. Unsure if this reagent suits your experiment?

**Need Industrial/Bulk Grade?** [Request Custom Synthesis Quote](#)

## BenchChem

Our mission is to be the trusted global source of essential and advanced chemicals, empowering scientists and researchers to drive progress in science and industry.

### Contact

Address: 3281 E Guasti Rd  
Ontario, CA 91761, United States  
Phone: (601) 213-4426  
Email: [info@benchchem.com](mailto:info@benchchem.com)

[Contact our Ph.D. Support Team for a compatibility check](#)