

Comparison of Synthetic Routes for Substituted Pyrazoles: A Technical Guide

Author: BenchChem Technical Support Team. **Date:** May 2026

Compound of Interest

Compound Name: *1-(4-Chlorophenyl)-3-phenylpyrazole-4-propionic acid*

CAS No.: 870704-02-2

Cat. No.: B1603376

Get Quote

Executive Summary

The pyrazole pharmacophore is ubiquitous in modern drug discovery (e.g., Celecoxib, Rimonabant), yet its synthesis often presents a "regioselectivity trap." The classical condensation methods, while scalable, frequently yield thermodynamic mixtures of 1,3- and 1,5-isomers that require tedious chromatographic separation.^[1]

This guide provides a technical comparison of the three dominant synthetic architectures:

- **Optimized Knorr Condensation:** The industrial workhorse, modernized with fluorinated solvents for regiocontrol.
- **[3+2] Dipolar Cycloaddition:** The precision tool for complex substitution patterns.
- **Late-Stage C-H Functionalization:** The diversification strategy for Structure-Activity Relationship (SAR) expansion.

Part 1: The Regioselectivity Challenge (Mechanism & Logic)

The core challenge in pyrazole synthesis is controlling the placement of substituents on the nitrogen (

) and the adjacent carbons (

vs

).

The Knorr Dilemma

In the classical reaction between a hydrazine (

) and an unsymmetrical 1,3-diketone, the hydrazine has two nucleophilic nitrogens (

and

), and the diketone has two electrophilic carbonyls. This creates four potential pathways, leading to isomeric mixtures.

Key Insight: Regiocontrol is dictated by the hard/soft character of the electrophiles and solvent proticity. In standard ethanol reflux, mixtures are common. In fluorinated alcohols (e.g., TFE, HFIP), hydrogen bonding activates specific carbonyls, driving selectivity.

Visualization: The Divergent Pathway

The following diagram illustrates the mechanistic bifurcation that leads to isomeric impurities.

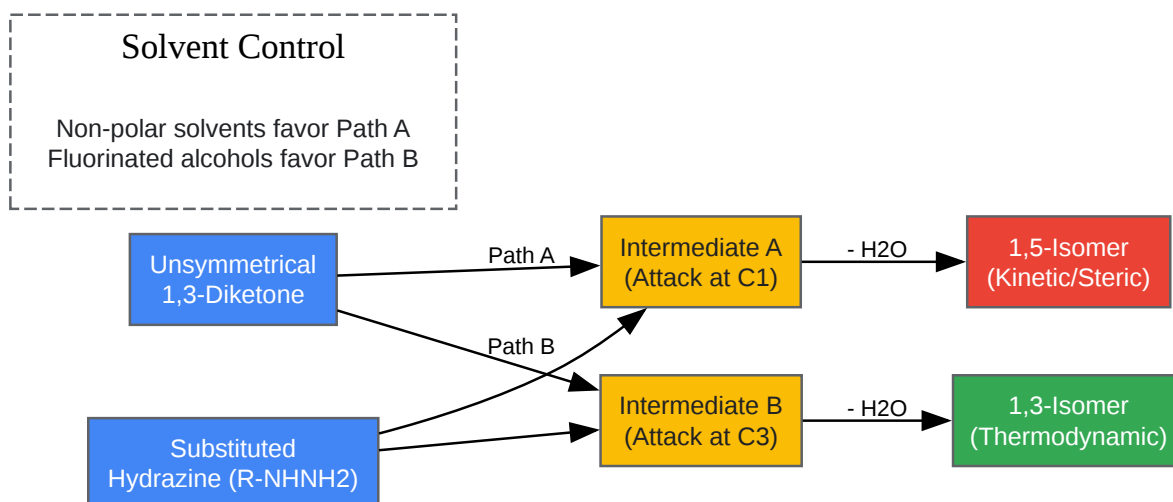

[Click to download full resolution via product page](#)

Figure 1: Mechanistic bifurcation in Knorr synthesis. Controlling the initial nucleophilic attack is critical for isomeric purity.

Part 2: Detailed Route Comparison

Route A: Optimized Knorr Condensation (TFE-Mediated)

Best for: Large-scale production of simple 1,3,5-trisubstituted pyrazoles.

While traditional ethanol reflux is non-selective, using Trifluoroethanol (TFE) or Hexafluoroisopropanol (HFIP) has been proven to enhance regioselectivity significantly. The acidic nature of these solvents activates the harder carbonyl, directing the initial attack.

- Pros: Cheap starting materials, scalable, high atom economy.[2]
- Cons: Limited tolerance for acid-sensitive groups; "regio-switching" requires extensive solvent screening.

Route B: [3+2] Dipolar Cycloaddition (Nitrilimines)

Best for: Complex cores, sensitive functional groups, and ensuring 100% regiocontrol.

This route typically involves the reaction of a hydrazonoyl chloride (generating a nitrilimine in situ) with an alkyne or alkene. Because the dipole (nitrilimine) and dipolarophile (alkyne) have

fixed electronic polarizations, the orientation of addition is strictly governed by FMO (Frontier Molecular Orbital) theory, often yielding a single isomer.

- Pros: Absolute regiocontrol, mild conditions (often room temp), modular.
- Cons: Multi-step synthesis of precursors (hydrazonoyl chlorides), potentially hazardous intermediates (diazo/nitrilimine).

Route C: Transition Metal C-H Functionalization

Best for: Late-stage SAR (Structure-Activity Relationship) exploration.

Starting from a simple N-methyl pyrazole, Pd- or Ru-catalyzed C-H activation can install aryl or alkyl groups at the

or

position.

- Pros: Rapid diversification of a single core scaffold.
- Cons: Expensive catalysts (Pd, Ru), requires directing groups, often lower yields than de novo synthesis.

Part 3: Comparative Performance Matrix

The following table synthesizes experimental data comparing these routes for the synthesis of a target 1-phenyl-3-(trifluoromethyl)-5-methylpyrazole analog.

Metric	Route A: Knorr (EtOH/AcOH)	Route A*: Knorr (TFE/TFA)	Route B: [3+2] Cycloaddition	Route C: C-H Arylation
Regioselectivity (1,5:1,3)	~60:40 (Mixture)	>95:5 (High Control)	>99:1 (Exclusive)	N/A (Site Selective)
Isolated Yield	85% (Combined)	78% (Single Isomer)	65-75%	50-70%
Atom Economy	High (Water byproduct)	High	Moderate (Halide waste)	Low (Oxidants/Ligands)
Reaction Time	2-4 Hours	12-24 Hours	6-12 Hours	24-48 Hours
Scalability	Excellent (kg scale)	Good (Solvent cost)	Moderate	Poor (Catalyst cost)
Green Metric	Amber (Acid waste)	Green (Recyclable TFE)	Amber (Chlorinated waste)	Red (Heavy metals)

Part 4: Experimental Protocols

Protocol 1: Regioselective Knorr Synthesis in Fluorinated Solvent

Target: 1-(4-chlorophenyl)-3-(trifluoromethyl)-5-methylpyrazole

Principle: The use of TFE (Trifluoroethanol) activates the trifluoroacetyl carbonyl via strong hydrogen bonding, directing the hydrazine attack to the acetyl group first.

- Setup: Equip a 100 mL round-bottom flask with a magnetic stir bar and a reflux condenser.
- Reagents:
 - 4,4,4-Trifluoro-1-phenylbutane-1,3-dione (1.0 equiv, 10 mmol)
 - 4-Chlorophenylhydrazine hydrochloride (1.1 equiv, 11 mmol)

- Solvent: 2,2,2-Trifluoroethanol (TFE) (20 mL, 0.5 M)
- Reaction:
 - Dissolve the diketone in TFE.
 - Add the hydrazine salt in one portion.
 - Critical Step: Add Trifluoroacetic acid (TFA) (10 mol%) to catalyze the dehydration and enhance carbonyl differentiation.
 - Heat to reflux (80 °C) for 12 hours. Monitor by TLC (Hexane/EtOAc 9:1) or LC-MS.
- Workup:
 - Cool to room temperature.[\[3\]](#)[\[4\]](#)[\[5\]](#)[\[6\]](#)
 - Remove TFE under reduced pressure (Rotavap). Note: TFE can be recovered and distilled for reuse.
 - Dissolve residue in EtOAc (50 mL) and wash with sat.
(2 x 20 mL) and Brine (20 mL).
 - Dry over
, filter, and concentrate.
- Purification: Recrystallize from Ethanol/Water to obtain the 1,5-isomer as white needles.

Protocol 2: [3+2] Cycloaddition via Nitrilimines

Target: 1-phenyl-3-carboethoxy-5-substituted pyrazole

Principle: In situ generation of a reactive nitrilimine dipole from a hydrazonoyl chloride, followed by trapping with an alkyne.

- Precursor Prep: Synthesize ethyl chloro(phenylhydrazono)acetate from aniline and ethyl 2-chloroacetoacetate (standard Japp-Klingemann reaction).

- Reaction:
 - In a 50 mL flask, dissolve the hydrazonoyl chloride (1.0 equiv) and the terminal alkyne (1.2 equiv) in dry THF or DCM.
 - Addition: Add Triethylamine () (1.5 equiv) dropwise over 30 minutes at 0 °C. The base dehydrohalogenates the precursor to form the nitrilimine.
 - Allow to warm to room temperature and stir for 6 hours.
- Observation: The formation of precipitate indicates reaction progress.
- Workup:
 - Filter off the amine salt.
 - Concentrate the filtrate.
- Purification: Flash chromatography (Silica gel, Hexane/EtOAc gradient). This route typically yields the 3,5-disubstituted product exclusively due to steric steering in the transition state.

Part 5: Decision Framework (Workflow)

Use this logic flow to select the optimal route for your specific drug candidate.

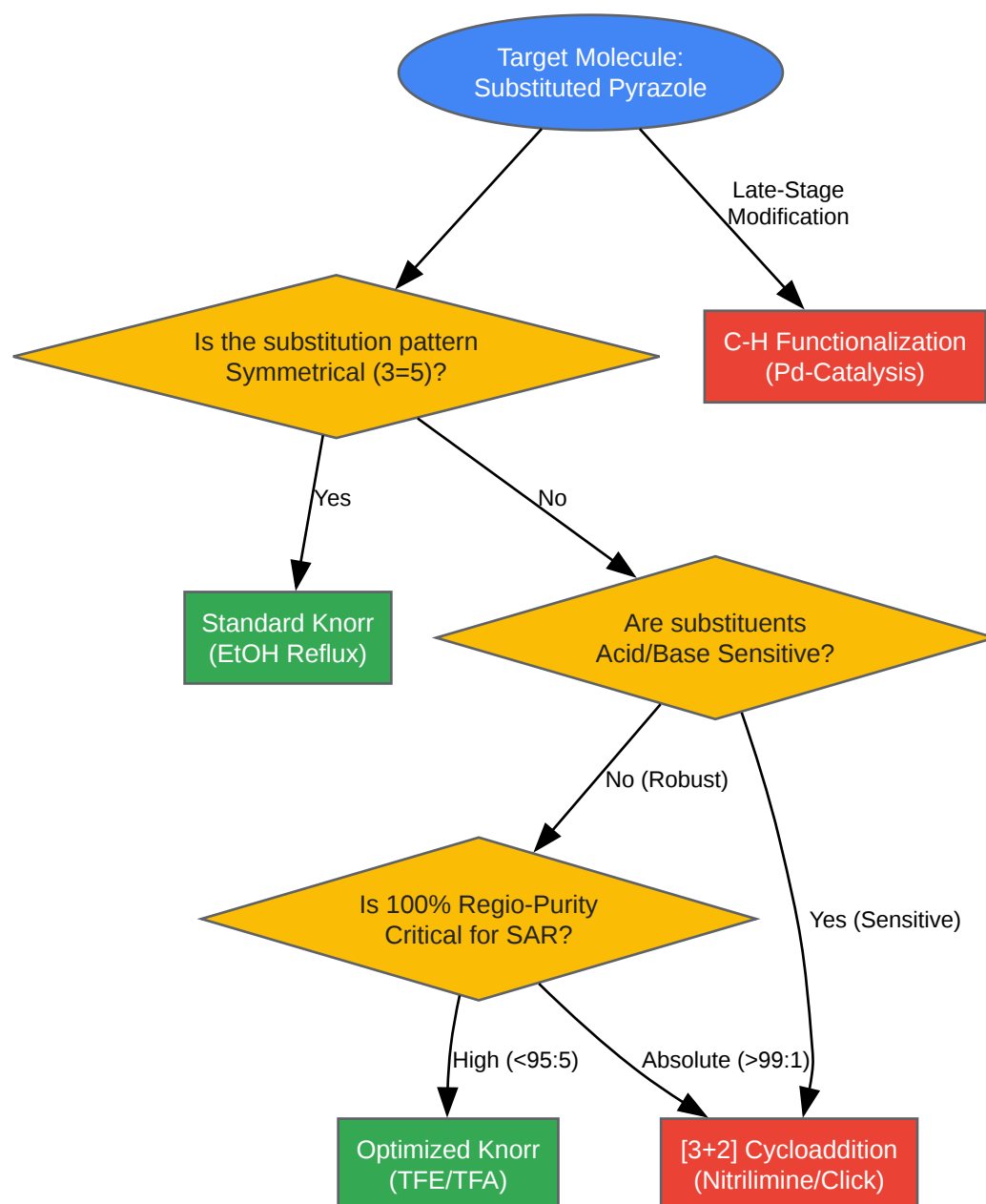

[Click to download full resolution via product page](#)

Figure 2: Strategic decision matrix for selecting synthetic methodology.

References

- Regioselective Synthesis of 1,3,5-Tri- and 1,3,4,5-Tetrasubstituted Pyrazoles. Organic Chemistry Portal. (Discusses the reaction of N-arylhydrazones with nitroolefins).

- Improved Regioselectivity in Pyrazole Formation through the Use of Fluorinated Alcohols. *Journal of Organic Chemistry*. (The definitive guide on using TFE/HFIP for Knorr synthesis).
- Regiocontrolled Synthesis of 1-Substituted-3(5)-carboxyalkyl-1H-pyrazoles. *PubMed Central / ACS Omega*. (Detailed mechanism on hydrazine nucleophilicity vs. enone electrophilicity).
- Transition-metal-catalyzed C–H functionalization of pyrazoles. *Royal Society of Chemistry (OBC)*. (Review of late-stage functionalization strategies).
- Green Methods for the Synthesis of Pyrazoles. *ResearchGate*. (Overview of solvent-free and aqueous protocols).

Need Custom Synthesis?

BenchChem offers custom synthesis for rare earth carbides and specific isotopic labeling.

Email: info@benchchem.com or [Request Quote Online](#).

Sources

- [1. Regiocontrolled Synthesis of 1-Substituted-3\(5\)-carboxyalkyl-1H-pyrazoles Using Trichloromethyl Enones - PMC \[pmc.ncbi.nlm.nih.gov\]](#)
- [2. researchgate.net \[researchgate.net\]](#)
- [3. ijrpc.com \[ijrpc.com\]](#)
- [4. Frontiers | Green Protocols in Heterocycle Syntheses via 1,3-Dipolar Cycloadditions \[frontiersin.org\]](#)
- [5. researchgate.net \[researchgate.net\]](#)
- [6. mdpi.com \[mdpi.com\]](#)
- To cite this document: BenchChem. [Comparison of Synthetic Routes for Substituted Pyrazoles: A Technical Guide]. BenchChem, [2026]. [Online PDF]. Available at: [\[https://www.benchchem.com/product/b1603376/docs#comparison-of-synthetic-routes-for-substituted-pyrazoles-a-technical-guide\]](https://www.benchchem.com/product/b1603376/docs#comparison-of-synthetic-routes-for-substituted-pyrazoles-a-technical-guide)

Disclaimer & Data Validity:

The information provided in this document is for Research Use Only (RUO) and is strictly not intended for diagnostic or therapeutic procedures. While BenchChem strives to provide accurate protocols, we make no warranties, express or implied, regarding the fitness of this product for every specific experimental setup.

Technical Support: The protocols provided are for reference purposes. Unsure if this reagent suits your experiment?

Need Industrial/Bulk Grade? [Request Custom Synthesis Quote](#)

BenchChem

Our mission is to be the trusted global source of essential and advanced chemicals, empowering scientists and researchers to drive progress in science and industry.

Contact

Address: 3281 E Guasti Rd
Ontario, CA 91761, United States
Phone: (601) 213-4426
Email: info@benchchem.com

[Contact our Ph.D. Support Team for a compatibility check](#)