

Application Notes and Protocols for Substituted Oxazole Compounds in Antimicrobial Research

Author: BenchChem Technical Support Team. **Date:** May 2026

Compound of Interest

Compound Name:	Methyl 4-methyloxazole-5-carboxylate
CAS No.:	23012-23-9
Cat. No.:	B1603076

[Get Quote](#)

Introduction: The Resurgence of the Oxazole Scaffold in Antimicrobial Drug Discovery

The oxazole nucleus, a five-membered aromatic heterocycle containing one oxygen and one nitrogen atom, represents a cornerstone in medicinal chemistry.^{[1][2]} Its unique electronic properties and structural versatility allow for diverse substitutions, leading to a wide spectrum of biological activities, including antimicrobial, anticancer, anti-inflammatory, and more.^{[1][2]} The rising tide of multidrug-resistant (MDR) pathogens has reignited interest in novel antimicrobial agents, and substituted oxazoles have emerged as a promising class of compounds to address this critical global health challenge.^[3]

This guide provides researchers, scientists, and drug development professionals with a comprehensive overview of the antimicrobial applications of substituted oxazole compounds. It delves into their mechanisms of action, provides detailed protocols for their synthesis and evaluation, and offers insights into the interpretation of results. The content herein is designed to be a practical resource, bridging the gap between theoretical knowledge and laboratory application.

Mechanism of Action: Targeting Essential Bacterial Processes

The antimicrobial efficacy of substituted oxazoles often stems from their ability to interfere with crucial cellular processes in bacteria and fungi. One of the most well-documented mechanisms involves the inhibition of the Filamenting temperature-sensitive mutant Z (FtsZ) protein.[4]

FtsZ is a prokaryotic homolog of eukaryotic tubulin and is essential for bacterial cell division.[5] It polymerizes at the mid-cell to form the Z-ring, which acts as a scaffold for the recruitment of other cell division proteins, ultimately leading to septum formation and cell scission.[5]

Substituted oxazoles have been shown to bind to FtsZ, disrupting its polymerization dynamics.[4] This can manifest in two primary ways:

- **Inhibition of Polymerization:** Some oxazole derivatives prevent the assembly of FtsZ monomers into protofilaments, thus blocking Z-ring formation altogether.[6]
- **Hyper-stabilization of Polymers:** Other compounds can bind to and stabilize FtsZ polymers, leading to the formation of non-functional, bundled structures that are unable to undergo the dynamic disassembly required for proper cell division.[6]

The net result of FtsZ disruption is the inhibition of cytokinesis, leading to filamentation of the bacterial cells and eventual cell death.[4]

Visualizing the Mechanism: FtsZ Inhibition by Substituted Oxazoles

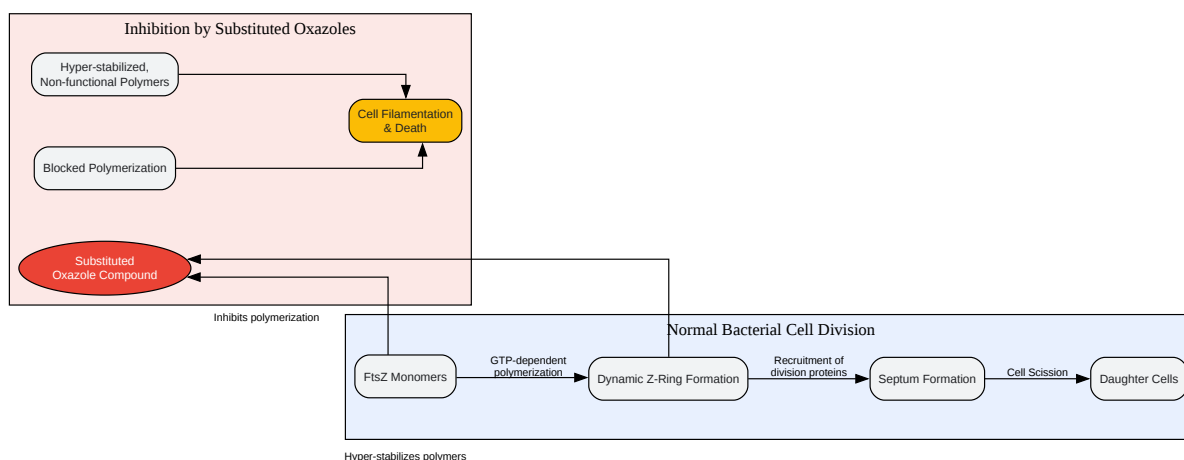

[Click to download full resolution via product page](#)

Caption: Mechanism of FtsZ inhibition by substituted oxazoles.

Synthesis of Substituted Oxazoles: Key Methodologies

The synthesis of the oxazole core and its derivatives can be achieved through several established methods. The choice of method often depends on the desired substitution pattern and the availability of starting materials.

Protocol 1: Robinson-Gabriel Synthesis

This classic method involves the cyclization and dehydration of an α -acylamino ketone to form a 2,5-disubstituted oxazole.[7][8]

Principle: An intramolecular cyclization is followed by dehydration under acidic conditions to form the aromatic oxazole ring.

Step-by-Step Protocol:

- Starting Material: Begin with an α -acylamino ketone. This can be synthesized by acylating an α -amino ketone.
- Cyclization/Dehydration:
 - Dissolve the α -acylamino ketone in a suitable solvent (e.g., toluene, xylene).
 - Add a dehydrating agent such as concentrated sulfuric acid (H_2SO_4), polyphosphoric acid (PPA), or phosphorus oxychloride (POCl_3).[7]
 - Heat the reaction mixture to reflux for several hours, monitoring the reaction progress by thin-layer chromatography (TLC).
- Work-up and Purification:
 - Cool the reaction mixture to room temperature and carefully neutralize the acid with a base (e.g., sodium bicarbonate solution).
 - Extract the product into an organic solvent (e.g., ethyl acetate).
 - Wash the organic layer with brine, dry over anhydrous sodium sulfate, and concentrate under reduced pressure.
 - Purify the crude product by column chromatography or recrystallization to obtain the desired substituted oxazole.

Protocol 2: Van Leusen Oxazole Synthesis

The Van Leusen reaction is a versatile method for preparing 5-substituted or 4,5-disubstituted oxazoles from an aldehyde and tosylmethyl isocyanide (TosMIC).[9][10]

Principle: This reaction proceeds via a base-mediated condensation of an aldehyde with TosMIC, followed by intramolecular cyclization and elimination of p-toluenesulfonic acid to form the oxazole.[11]

Step-by-Step Protocol:

- Reaction Setup:
 - In a round-bottom flask, dissolve the aldehyde (1 equivalent) and TosMIC (1 equivalent) in a suitable solvent such as methanol or dimethoxyethane (DME).
 - Add a base, such as potassium carbonate (K_2CO_3) or sodium hydride (NaH), to the mixture.
- Reaction Execution:
 - Stir the reaction mixture at room temperature or under reflux, depending on the reactivity of the aldehyde.[11] The reaction is typically complete within a few hours.
 - Monitor the progress of the reaction by TLC.
- Work-up and Purification:
 - Once the reaction is complete, remove the solvent under reduced pressure.
 - Add water to the residue and extract the product with an organic solvent (e.g., dichloromethane or ethyl acetate).
 - Wash the combined organic layers with water and brine, dry over anhydrous sodium sulfate, and concentrate in vacuo.
 - Purify the resulting crude product by column chromatography on silica gel to yield the pure substituted oxazole.

Workflow for Synthesis and Evaluation of Antimicrobial Oxazoles

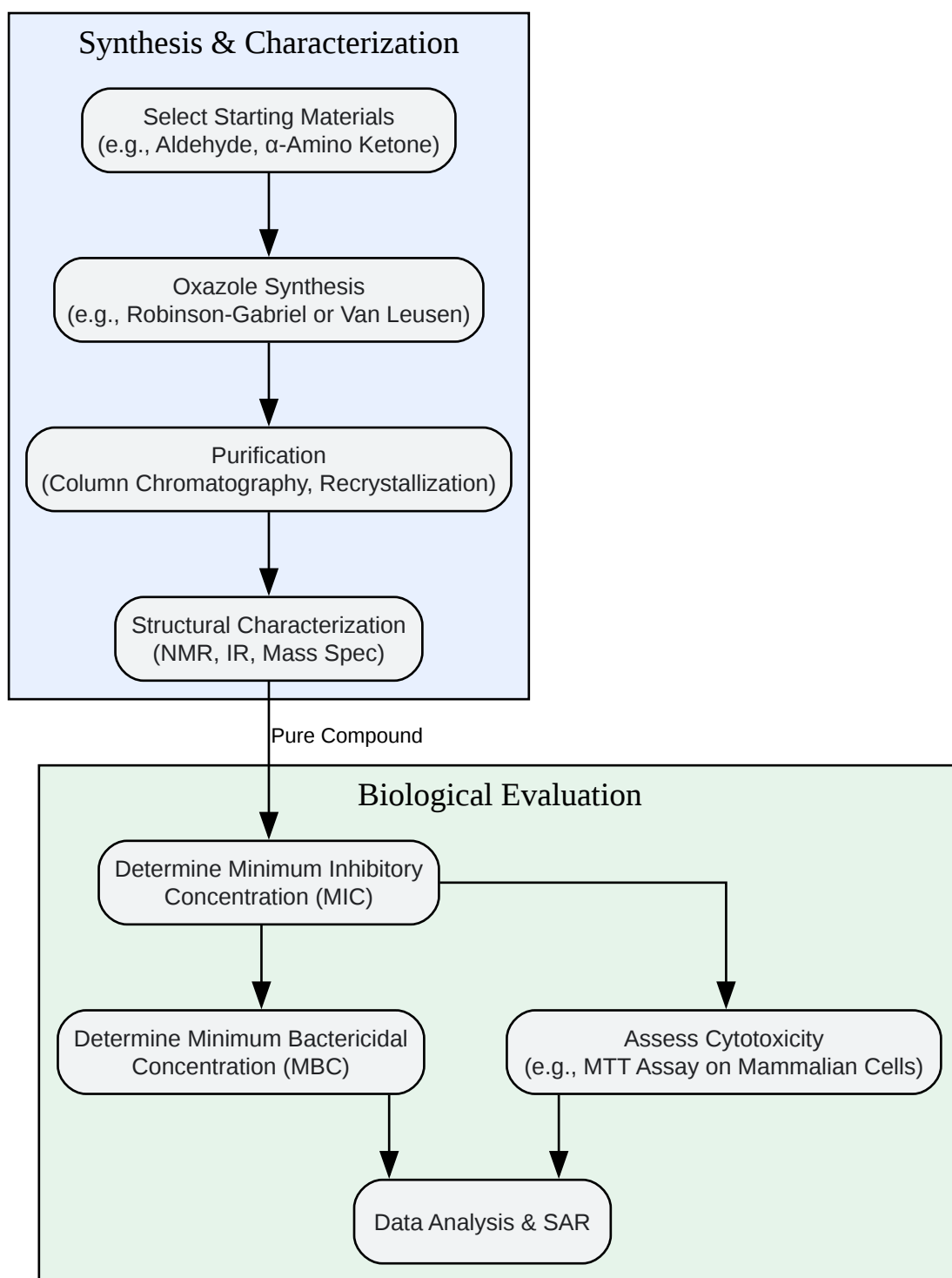

[Click to download full resolution via product page](#)

Caption: General workflow from synthesis to biological evaluation.

Protocols for Antimicrobial and Cytotoxicity Evaluation

Once synthesized and purified, the novel oxazole compounds must be rigorously tested for their biological activity.

Protocol 3: Determination of Minimum Inhibitory Concentration (MIC) by Broth Microdilution

This is a quantitative method to determine the lowest concentration of an antimicrobial agent that inhibits the visible growth of a microorganism.[12][13]

Materials:

- 96-well microtiter plates[13]
- Test oxazole compound, dissolved in a suitable solvent (e.g., DMSO)
- Bacterial or fungal culture in logarithmic growth phase
- Appropriate sterile broth medium (e.g., Mueller-Hinton Broth for bacteria)[14]
- Positive control (microorganism in broth without compound)
- Negative control (broth only)
- Standard antibiotic (e.g., ciprofloxacin, ampicillin)

Step-by-Step Protocol:

- Prepare Compound Dilutions:
 - In the first column of a 96-well plate, add the test compound to the broth to achieve twice the highest desired final concentration.
 - Perform a two-fold serial dilution by transferring half the volume from the first column to the second, and so on, across the plate.[12]

- Inoculum Preparation:
 - Adjust the turbidity of the microbial culture to match a 0.5 McFarland standard (approximately 1.5×10^8 CFU/mL).
 - Dilute this standardized inoculum in broth to achieve a final concentration of approximately 5×10^5 CFU/mL in the wells.
- Inoculation:
 - Add the prepared inoculum to each well containing the compound dilutions. The final volume in each well should be uniform (e.g., 100 μ L).
- Incubation:
 - Incubate the plate at the optimal temperature for the microorganism (e.g., 37°C for most bacteria) for 18-24 hours.[\[15\]](#)
- Reading the MIC:
 - The MIC is the lowest concentration of the compound at which there is no visible growth (i.e., the well remains clear). This can be assessed visually or by using a plate reader to measure optical density.

Protocol 4: Agar Well Diffusion Assay

This is a qualitative or semi-quantitative method to assess the antimicrobial activity of a compound.[\[3\]](#)[\[16\]](#)

Materials:

- Petri dishes with a suitable agar medium (e.g., Mueller-Hinton Agar)
- Microbial inoculum (adjusted to 0.5 McFarland standard)
- Sterile cotton swabs
- Sterile cork borer or pipette tip to create wells

- Test oxazole compound at a known concentration
- Solvent control (e.g., DMSO)
- Positive control (standard antibiotic solution)

Step-by-Step Protocol:

- Inoculate the Agar Plate:
 - Dip a sterile swab into the standardized microbial inoculum and streak it evenly across the entire surface of the agar plate to create a lawn of bacteria.
- Create Wells:
 - Use a sterile cork borer to punch uniform wells into the agar.[\[17\]](#)
- Add Test Compounds:
 - Carefully pipette a fixed volume (e.g., 50-100 μ L) of the test compound solution, solvent control, and positive control into separate wells.[\[17\]](#)
- Incubation:
 - Incubate the plates at the appropriate temperature (e.g., 37°C) for 18-24 hours.
- Measure Zone of Inhibition:
 - Measure the diameter of the clear zone around each well where microbial growth has been inhibited. A larger zone of inhibition indicates greater antimicrobial activity.

Protocol 5: Cytotoxicity Assessment using the MTT Assay

It is crucial to determine if the antimicrobial compounds are selectively toxic to microbes or also harm mammalian cells. The MTT assay is a colorimetric assay for assessing cell metabolic activity.[\[2\]](#)[\[18\]](#)

Materials:

- Mammalian cell line (e.g., HeLa, HEK293)
- 96-well cell culture plates
- Complete cell culture medium
- Test oxazole compound
- MTT (3-(4,5-dimethylthiazol-2-yl)-2,5-diphenyltetrazolium bromide) solution[19]
- Solubilization solution (e.g., DMSO, acidified isopropanol)

Step-by-Step Protocol:

- Cell Seeding:
 - Seed the mammalian cells into a 96-well plate at a predetermined density and allow them to adhere overnight.
- Compound Treatment:
 - Prepare serial dilutions of the test oxazole compound in cell culture medium and add them to the wells. Include untreated cells as a control.
 - Incubate for a specified period (e.g., 24, 48, or 72 hours).[19]
- MTT Addition:
 - Add MTT solution to each well and incubate for 2-4 hours.[2] Metabolically active cells will reduce the yellow MTT to purple formazan crystals.[18]
- Solubilization:
 - Remove the medium and add a solubilization solution to dissolve the formazan crystals.
[20]
- Absorbance Reading:

- Measure the absorbance of the solubilized formazan at a wavelength of approximately 570 nm using a microplate reader.
- Data Analysis:
 - Calculate the percentage of cell viability compared to the untreated control. This allows for the determination of the compound's cytotoxic concentration (e.g., CC₅₀).

Data Presentation and Interpretation

The data generated from these assays should be systematically organized to facilitate structure-activity relationship (SAR) studies.

Table 1: Antimicrobial Activity and Cytotoxicity of Representative Substituted Oxazoles

Compound ID	R ¹ Substituent	R ² Substituent	R ³ Substituent	MIC (µg/mL) vs. S. aureus	MIC (µg/mL) vs. E. coli	MIC (µg/mL) vs. C. albicans	CC ₅₀ (µg/mL) vs. HeLa cells
OX-1	Phenyl	Methyl	H	16	>128	64	>128
OX-2	4-Chlorophenyl	Methyl	H	4	64	32	100
OX-3	4-Nitrophenyl	Methyl	H	2	32	16	50
OX-4	Phenyl	Trifluoromethyl	H	8	>128	32	>128
OX-5	4-Chlorophenyl	H	4-Fluorophenyl	1	16	8	80

(Note: The data in this table is illustrative and intended for demonstration purposes only. Actual values must be determined experimentally.)

Interpretation:

- **Structure-Activity Relationship (SAR):** By comparing the structures and activities of different analogs (e.g., OX-1, OX-2, and OX-3), one can deduce the influence of specific substituents on antimicrobial potency. For instance, the addition of electron-withdrawing groups like chloro and nitro at the para position of the phenyl ring appears to enhance activity against *S. aureus*.
- **Selectivity Index (SI):** The SI is a crucial parameter in drug development, calculated as CC_{50} / MIC . A higher SI value indicates greater selectivity for the microbial target over host cells, which is a desirable characteristic for a potential therapeutic agent.

Conclusion and Future Directions

Substituted oxazoles continue to be a fertile ground for the discovery of new antimicrobial agents. The protocols and methodologies outlined in this guide provide a robust framework for the synthesis, evaluation, and characterization of novel oxazole-based compounds. Future research should focus on optimizing the SAR to enhance potency and broaden the spectrum of activity, while minimizing cytotoxicity. Furthermore, exploring other potential mechanisms of action beyond FtsZ inhibition could unveil new avenues for combating drug-resistant pathogens. The systematic application of these protocols will undoubtedly accelerate the journey of promising oxazole candidates from the laboratory to clinical applications.

References

- A brief review on antimicrobial activity of oxazole derivatives - *iajps*. (URL: [\[Link\]](#))
- Kakkar, S., & Narasimhan, B. (2019). A comprehensive review on biological activities of oxazole derivatives. *BMC chemistry*, 13(1), 16. (URL: [\[Link\]](#))
- Synthesis, Reactions and Medicinal Uses of Oxazole - *Pharmaguideline*. (URL: [\[Link\]](#))
- Swellmeen, L. (2016). 1,3-Oxazole Derivatives: A Review of Biological Activities as Antipathogenic. *Der Pharma Chemica*, 8(13), 269-286. (URL: [\[Link\]](#))

- Limban, C., et al. (2021). Synthesis, In Silico and In Vitro Evaluation of Antimicrobial and Toxicity Features of New 4-[(4-Chlorophenyl)sulfonyl]benzoic Acid Derivatives. *Molecules*, 26(17), 5123. (URL: [\[Link\]](#))
- Al-Amiery, A. A., et al. (2012). Antimicrobial Activity And Characterization of Some Oxazole, Thiazol And Quinoline. *Organic Chemistry: An Indian Journal*, 8(4). (URL: [\[Link\]](#))
- Zheng, X., et al. (2020). Recent Advances in the Synthesis of Oxazole-Based Molecules via van Leusen Oxazole Synthesis. *Molecules*, 25(7), 1594. (URL: [\[Link\]](#))
- Synthesis of 1,3-oxazoles - Organic Chemistry Portal. (URL: [\[Link\]](#))
- MIC Determination By Microtitre Broth Dilution Method - Hancock Lab. (URL: [\[Link\]](#))
- Artola, M., et al. (2020). Recent Progress in the Development of Small-Molecule FtsZ Inhibitors as Chemical Tools for the Development of Novel Antibiotics. *Molecules*, 25(21), 5213. (URL: [\[Link\]](#))
- Van Leusen Oxazole Synthesis - Organic Chemistry Portal. (URL: [\[Link\]](#))
- Synthesis and antimicrobial evaluation of novel oxazole amide derivatives. (2024). *Journal of Chemical and Pharmaceutical Research*, 16(8), 1-8. (URL: [\[Link\]](#))
- Balouiri, M., et al. (2016). Methods for in vitro evaluating antimicrobial activity: A review. *Journal of pharmaceutical analysis*, 6(2), 71–79. (URL: [\[Link\]](#))
- Robinson-Gabriel synthesis for oxazole - ResearchGate. (URL: [\[Link\]](#))
- Agar well diffusion: A prominent method for In vitro screening of antimicrobials. (2021). *GSC Biological and Pharmaceutical Sciences*, 16(3), 209-215. (URL: [\[Link\]](#))
- Holder, I. A., & Boyce, S. T. (1994). Agar well diffusion assay testing of bacterial susceptibility to various antimicrobials in concentrations non-toxic for human cells in culture. *Burns*, 20(5), 426-429. (URL: [\[Link\]](#))
- MTT Assay Protocol - Assay Guidance Manual - NCBI Bookshelf. (2013). (URL: [\[Link\]](#))

- Ferrer-González, E., et al. (2021). Targeting the Achilles Heel of FtsZ: The Interdomain Cleft. *Frontiers in Molecular Biosciences*, 8, 706915. (URL: [\[Link\]](#))
- Agar well-diffusion antimicrobial assay - ResearchGate. (URL: [\[Link\]](#))
- Cytotoxicity MTT Assay Protocols and Methods | Springer Nature Experiments. (URL: [\[Link\]](#))
- Consensus Method for Broth Microdilution Assay - Methods for Antimicrobial Susceptibility Testing for Human Mycoplasmas; Approved Guideline - NCBI Bookshelf. (2011). (URL: [\[Link\]](#))
- Denivelle, S., et al. (2020). Cell Division Protein FtsZ: From Structure and Mechanism to Antibiotic Target. *International Journal of Molecular Sciences*, 21(14), 5103. (URL: [\[Link\]](#))
- Robinson-Gabriel synthesis of oxazoles | Organic Chemistry - YouTube. (2023). (URL: [\[Link\]](#))
- MTT assay protocol - Protocols.io. (2023). (URL: [\[Link\]](#))
- FtsZ Interactions and Biomolecular Condensates as Potential Targets for New Antibiotics. (2021). *International Journal of Molecular Sciences*, 22(16), 8758. (URL: [\[Link\]](#))
- FtsZ as a novel target for antibiotics development: Promises and challenges. (2024). *MedComm*, 5(1), e450. (URL: [\[Link\]](#))
- Minimum Inhibitory Concentration (MIC) and Minimum Bactericidal Concentration (MBC) Assays Using Broth Microdilution Method - Protocols.io. (2023). (URL: [\[Link\]](#))
- Broth Microdilution assay - How to determine the MIC (Minimum Inhibitory Concentration). (2021). (URL: [\[Link\]](#))

Need Custom Synthesis?

BenchChem offers custom synthesis for rare earth carbides and specific isotopic labeling.

Email: info@benchchem.com or [Request Quote Online](#).

Sources

- [1. scribd.com \[scribd.com\]](https://www.scribd.com)
- [2. atcc.org \[atcc.org\]](https://www.atcc.org)
- [3. chemistnotes.com \[chemistnotes.com\]](https://www.chemistnotes.com)
- [4. Recent Progress in the Development of Small-Molecule FtsZ Inhibitors as Chemical Tools for the Development of Novel Antibiotics - PMC \[pmc.ncbi.nlm.nih.gov\]](#)
- [5. researchgate.net \[researchgate.net\]](https://www.researchgate.net)
- [6. mdpi.com \[mdpi.com\]](https://www.mdpi.com)
- [7. Synthesis, Reactions and Medicinal Uses of Oxazole | Pharmaguideline \[pharmaguideline.com\]](#)
- [8. m.youtube.com \[m.youtube.com\]](https://m.youtube.com)
- [9. Recent Advances in the Synthesis of Oxazole-Based Molecules via van Leusen Oxazole Synthesis - PMC \[pmc.ncbi.nlm.nih.gov\]](#)
- [10. Van Leusen Oxazole Synthesis \[organic-chemistry.org\]](https://www.organic-chemistry.org)
- [11. pdf.benchchem.com \[pdf.benchchem.com\]](https://pdf.benchchem.com)
- [12. MIC Determination By Microtitre Broth Dilution Method - Hancock Lab \[cmdr.ubc.ca\]](#)
- [13. Methods for Antimicrobial Susceptibility Testing for Human Mycoplasmas; Approved Guideline - NCBI Bookshelf \[ncbi.nlm.nih.gov\]](#)
- [14. protocols.io \[protocols.io\]](https://www.protocols.io)
- [15. m.youtube.com \[m.youtube.com\]](https://m.youtube.com)
- [16. botanyjournals.com \[botanyjournals.com\]](https://www.botanyjournals.com)
- [17. webcentral.uc.edu \[webcentral.uc.edu\]](https://webcentral.uc.edu)
- [18. Cytotoxicity MTT Assay Protocols and Methods | Springer Nature Experiments \[experiments.springernature.com\]](#)
- [19. MTT \(Assay protocol \[protocols.io\]](#)
- [20. Cell Viability Assays - Assay Guidance Manual - NCBI Bookshelf \[ncbi.nlm.nih.gov\]](#)
- To cite this document: BenchChem. [Application Notes and Protocols for Substituted Oxazole Compounds in Antimicrobial Research]. BenchChem, [2026]. [Online PDF]. Available at: [<https://www.benchchem.com/product/b1603076/docs#application-notes-and-protocols-for-substituted-oxazole-compounds-in-antimicrobial-research>]

Disclaimer & Data Validity:

The information provided in this document is for Research Use Only (RUO) and is strictly not intended for diagnostic or therapeutic procedures. While BenchChem strives to provide accurate protocols, we make no warranties, express or implied, regarding the fitness of this product for every specific experimental setup.

Technical Support: The protocols provided are for reference purposes. Unsure if this reagent suits your experiment?

Need Industrial/Bulk Grade? [Request Custom Synthesis Quote](#)

BenchChem

Our mission is to be the trusted global source of essential and advanced chemicals, empowering scientists and researchers to drive progress in science and industry.

Contact

Address: 3281 E Guasti Rd
Ontario, CA 91761, United States
Phone: (601) 213-4426
Email: info@benchchem.com

[Contact our Ph.D. Support Team for a compatibility check](#)