

Application Note: Functionalization of 5-Bromoquinolin-2-amine

Author: BenchChem Technical Support Team. **Date:** May 2026

Compound of Interest

Compound Name: 5-Bromoquinolin-2-amine

CAS No.: 347146-12-7

Cat. No.: B1603988

[Get Quote](#)

Strategic Analysis & Scaffold Reactivity

Objective: Selective functionalization of the C5-position while preserving or leveraging the C2-amine.

Chemo-Selectivity Challenge: The C2-amine is electron-donating, increasing electron density on the quinoline ring. While this deactivates the ring towards nucleophilic aromatic substitution (

), it facilitates oxidative addition at the C5-Br bond by Pd(0) species. However, the free amine protons (

) can quench organometallic intermediates (e.g., organolithiums) or coordinate to the metal center, poisoning the catalyst.

Operational Decision Tree:

- For Pd-Catalyzed Couplings (Suzuki, Heck, Sonogashira): The free amine is generally tolerated but may require higher catalyst loading or specific ligands (e.g., phosphines) to outcompete amine coordination.

- For Organolithium/Grignard Chemistry: The C2-amine must be protected (e.g., Boc, Piv, or Acetyl) to prevent proton quenching.
- For C-N Couplings (Buchwald-Hartwig): Selective C5-amination over N2-arylation is achieved by exploiting the acidity difference and nucleophilicity of the exogenous amine vs. the quinolinyl amine.

Reactivity Flowchart

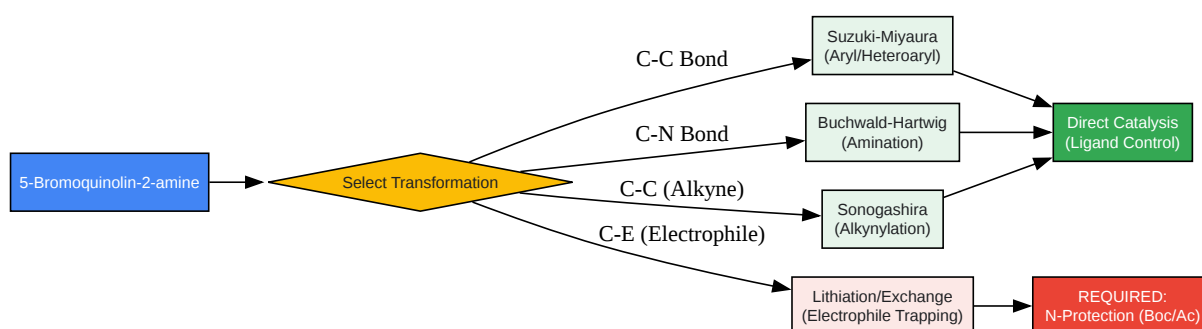

[Click to download full resolution via product page](#)

Caption: Decision logic for selecting reaction pathways based on the desired transformation and protecting group requirements.

Detailed Experimental Protocols

Protocol A: Suzuki-Miyaura Coupling (C-C Bond Formation)

Target: Introduction of aryl or heteroaryl groups at C5. Mechanism: Pd(0)-catalyzed cycle involving oxidative addition, transmetalation, and reductive elimination.[2]

Reagents & Conditions:

- Substrate: **5-Bromoquinolin-2-amine** (1.0 equiv)

- Boronic Acid: Aryl-B(OH)₂ (1.2–1.5 equiv)^[3]
- Catalyst: Pd(dppf)Cl₂·DCM (3–5 mol%) or Pd(PPh₃)₄ (5 mol%)
- Base: 2M Na₂CO₃ or K₃PO₄ (3.0 equiv)
- Solvent: 1,4-Dioxane/Water (4:^[3]^[4]1) or DME/Water
- Temp: 80–100 °C

Step-by-Step Procedure:

- Setup: In a glovebox or under Argon flow, charge a microwave vial or Schlenk flask with **5-bromoquinolin-2-amine** (1.0 mmol), boronic acid (1.2 mmol), and base (3.0 mmol).
- Catalyst Addition: Add the Pd catalyst (0.05 mmol). Note: Pd(dppf)Cl₂ is preferred for sterically hindered boronic acids.
- Solvation: Add degassed 1,4-dioxane (4 mL) and water (1 mL). Seal the vessel immediately.
- Reaction: Heat to 90 °C for 4–12 hours. Monitor by LC-MS (Target mass = MW_{boronic - B(OH)₂} + MW_{quinoline - Br}).
- Workup: Cool to RT. Dilute with EtOAc, wash with water and brine.^[3] Dry over MgSO₄.^[5]
- Purification: Flash chromatography (Hexane/EtOAc gradient). The free amine product is polar; consider adding 1% Et₃N to the eluent.

Protocol B: Buchwald-Hartwig Amination (C-N Bond Formation)

Target: Introduction of secondary amines at C5. Critical Factor: Ligand selection is vital to prevent competitive coupling at the C2-amine (though C5-Br is significantly more reactive towards oxidative addition).

Reagents & Conditions:

- Substrate: **5-Bromoquinolin-2-amine** (1.0 equiv)

- Nucleophile: Primary or Secondary Amine (1.2 equiv)
- Catalyst: Pd₂(dba)₃ (2 mol%)
- Ligand: BrettPhos or XPhos (4–8 mol%)
- Base: NaOtBu (Sodium tert-butoxide) (1.4 equiv)
- Solvent: Toluene or t-Amyl Alcohol (Anhydrous)
- Temp: 100 °C

Step-by-Step Procedure:

- Inert Atmosphere: Flame-dry a Schlenk tube and cool under Argon.
- Reagent Charging: Add Pd₂(dba)₃, Ligand, NaOtBu, and **5-bromoquinolin-2-amine**.
- Solvent & Amine: Add anhydrous Toluene. If the nucleophilic amine is liquid, add it via syringe.^[3]
- Activation: Heat to 100 °C. The bulky BrettPhos ligand forms a monoligated Pd species that facilitates oxidative addition into the hindered C5-Br bond while minimizing coordination of the C2-amine.
- Completion: Reaction typically completes in 2–6 hours.
- Workup: Filter through a Celite pad. Concentrate and purify via silica gel chromatography.

Protocol C: Sonogashira Coupling (Alkynylation)

Target: Introduction of alkyne linkers (often for "Click" chemistry or rigid spacers).

Reagents & Conditions:

- Catalyst: Pd(PPh₃)₂Cl₂ (5 mol%)
- Co-Catalyst: CuI (2 mol%)

- Base: Et₃N or Diisopropylamine (used as solvent or co-solvent)
- Alkyne: Terminal Alkyne (1.2 equiv)
- Temp: 60–80 °C

Step-by-Step Procedure:

- Deoxygenation: Degas the amine solvent (Et₃N) vigorously with Argon for 15 mins. Oxygen promotes homocoupling of the alkyne (Glaser coupling).
- Mixing: Combine halide, Pd catalyst, and CuI in the vessel.
- Initiation: Add the alkyne and solvent.
- Heating: Stir at 60 °C. Note: If the C₂-amine interferes with CuI, increase CuI loading to 5 mol% or switch to a Copper-free protocol using Pd(OAc)₂/XPhos.

Data Presentation & Optimization Guide

Catalyst & Ligand Screening Matrix

The following table summarizes optimal conditions based on substrate sterics and electronics.

Reaction Type	Preferred Catalyst	Ligand Class	Base	Solvent	Yield Target
Suzuki	Pd(dppf)Cl ₂	Bidentate Ferrocenyl	K ₃ PO ₄	Dioxane/H ₂ O	>85%
Buchwald	Pd ₂ (dba) ₃	Dialkylbiaryl (BrettPhos)	NaOtBu	Toluene	70-90%
Sonogashira	Pd(PPh ₃) ₂ Cl ₂	Monodentate Phosphine	Et ₃ N	DMF/Et ₃ N	60-80%
Heck	Pd(OAc) ₂	P(o-tol) ₃	Et ₃ N	DMF	50-75%

Troubleshooting "Stalled" Reactions

If conversion stalls at <50%:

- Check for Poisoning: The C2-amine may be binding Pd. Solution: Add a protecting group (e.g., heat with Ac₂O to form the acetamide) then perform the coupling. Deprotect with K₂CO₃/MeOH later.
- Debromination: If the product is the hydro-dehalogenated quinoline, the hydride source is likely the solvent or base. Solution: Switch from isopropanol/alcohol solvents to Toluene/Dioxane.

References

- Suzuki-Miyaura Coupling of 5-Bromonicotinaldehyde (Analogous Protocol): BenchChem. "Application Notes and Protocols for the Suzuki Coupling Reaction of 5-Bromonicotinaldehyde."
- Buchwald-Hartwig Amination Principles: Organic Chemistry Portal. "Buchwald-Hartwig Cross Coupling Reaction." [6][7]
- Sonogashira Coupling Mechanism & Protocols: Chemistry LibreTexts. "Sonogashira Coupling."
- BACE1 Inhibitor Synthesis (Scaffold Relevance): National Institutes of Health (NIH). "Scaffold Morphing and In Silico Design of Potential BACE-1 Inhibitors."

Need Custom Synthesis?

BenchChem offers custom synthesis for rare earth carbides and specific isotopic labeling.

Email: info@benchchem.com or [Request Quote Online](#).

Sources

- [1. pdf.benchchem.com](https://pdf.benchchem.com) [pdf.benchchem.com]
- [2. chem.libretexts.org](https://chem.libretexts.org) [chem.libretexts.org]
- [3. pdf.benchchem.com](https://pdf.benchchem.com) [pdf.benchchem.com]

- [4. mdpi.com \[mdpi.com\]](https://www.mdpi.com)
- [5. rose-hulman.edu \[rose-hulman.edu\]](https://www.rose-hulman.edu)
- [6. pdf.benchchem.com \[pdf.benchchem.com\]](https://pdf.benchchem.com)
- [7. Buchwald-Hartwig Cross Coupling Reaction \[organic-chemistry.org\]](https://www.organic-chemistry.org)
- To cite this document: BenchChem. [Application Note: Functionalization of 5-Bromoquinolin-2-amine]. BenchChem, [2026]. [Online PDF]. Available at: [\[https://www.benchchem.com/product/b1603988/docs#application-note-functionalization-of-5-bromoquinolin-2-amine\]](https://www.benchchem.com/product/b1603988/docs#application-note-functionalization-of-5-bromoquinolin-2-amine)

Disclaimer & Data Validity:

The information provided in this document is for Research Use Only (RUO) and is strictly not intended for diagnostic or therapeutic procedures. While BenchChem strives to provide accurate protocols, we make no warranties, express or implied, regarding the fitness of this product for every specific experimental setup.

Technical Support: The protocols provided are for reference purposes. Unsure if this reagent suits your experiment?

Need Industrial/Bulk Grade? [Request Custom Synthesis Quote](#)

BenchChem

Our mission is to be the trusted global source of essential and advanced chemicals, empowering scientists and researchers to drive progress in science and industry.

Contact

Address: 3281 E Guasti Rd
Ontario, CA 91761, United States
Phone: (601) 213-4426
Email: info@benchchem.com

[Contact our Ph.D. Support Team for a compatibility check](#)

