

A Comparative Analysis of Boc-Protection Methods for Amine Functional Groups

Author: BenchChem Technical Support Team. **Date:** May 2026

Compound of Interest

Compound Name:	4-((tert-Butoxycarbonyl)(methyl)amino)butanoic acid
CAS No.:	94994-39-5
Cat. No.:	B1603712

[Get Quote](#)

In the landscape of modern organic synthesis, particularly in the realms of peptide synthesis, medicinal chemistry, and drug development, the strategic use of protecting groups is paramount. The tert-butoxycarbonyl (Boc) group is arguably one of the most ubiquitous protecting groups for amines due to its robustness under various conditions and its facile, acid-labile removal.^{[1][2]} This guide provides an in-depth comparative analysis of the most common methods for the introduction of the Boc protecting group, offering field-proven insights and experimental data to aid researchers in selecting the optimal strategy for their specific synthetic challenges.

The Enduring Importance of the Boc Group

The Boc group's popularity stems from a delicate balance of stability and reactivity. It effectively shields the nucleophilic and basic nature of amines from a wide array of non-acidic reagents, yet can be cleaved under mild acidic conditions, often with high selectivity. This "orthogonality" is crucial in multi-step syntheses where other protecting groups, such as the base-labile Fmoc or the hydrogenolysis-cleavable Cbz group, are present.^{[3][4]} The choice of the Boc-protection method can significantly impact yield, purity, and overall efficiency of a synthetic route. This

guide will dissect the most common reagents used for this transformation: di-tert-butyl dicarbonate (Boc₂O or Boc anhydride), 2-(tert-butoxycarbonyloxyimino)-2-phenylacetonitrile (Boc-ON), and tert-butyl chloroformate (Boc-Cl).

I. Di-tert-butyl Dicarbonate (Boc₂O): The Workhorse Reagent

Di-tert-butyl dicarbonate is the most widely used reagent for Boc protection due to its commercial availability, ease of handling, and high efficiency.[1]

Mechanistic Rationale

The reaction proceeds via a nucleophilic attack of the amine on one of the carbonyl carbons of Boc anhydride. This forms a transient tetrahedral intermediate which then collapses, releasing tert-butyl carbonate. The tert-butyl carbonate subsequently decomposes to the stable byproducts tert-butanol and carbon dioxide, the evolution of which drives the reaction to completion.[5][6] While the reaction can proceed without a base, one is often added to neutralize the protonated amine, thereby increasing the concentration of the free amine and accelerating the reaction.[5]

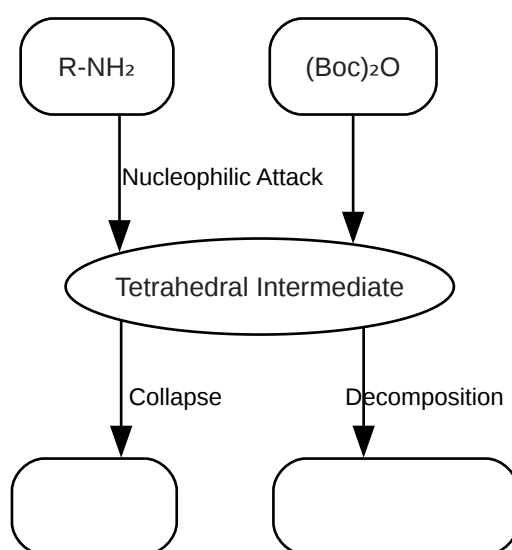

[Click to download full resolution via product page](#)

Mechanism of Boc Protection using Boc₂O.

Experimental Considerations and Data

Boc protection using Boc₂O is highly versatile and can be performed under a variety of conditions, including aqueous, anhydrous, and even solvent-free systems.[1][3] The choice of solvent and base depends on the substrate's solubility and reactivity.

Typical Reaction Conditions:

- **Aqueous/Organic Biphasic:** A common method involves dissolving the amine in a mixture of water and an organic solvent like THF or dioxane, with a base such as sodium hydroxide or sodium bicarbonate.[1]
- **Anhydrous Organic:** For moisture-sensitive substrates, solvents like THF, acetonitrile, or dichloromethane (DCM) are used with an organic base like triethylamine (TEA) or N,N-diisopropylethylamine (DIPEA).[6]
- **Catalytic DMAP:** The addition of a catalytic amount of 4-dimethylaminopyridine (DMAP) can significantly accelerate the reaction, especially for less nucleophilic or sterically hindered amines.[7] However, care must be taken as DMAP can promote side reactions.[7]

Substrate Type	Reagent System	Solvent	Temp. (°C)	Time (h)	Yield (%)	Reference
Primary Aliphatic Amine	Boc ₂ O, NaOH	Dioxane/H ₂ O	RT	1-4	>95	[1]
Primary Arylamine	Boc ₂ O, TEA	THF	RT	2-6	90-98	[6]
Secondary Aliphatic Amine	Boc ₂ O, DMAP (cat.)	DCM	RT	12-24	85-95	[7]
Amino Acid	Boc ₂ O, NaHCO ₃	Dioxane/H ₂ O	RT	2-5	>95	[4]

Note: Reaction times and yields are representative and can vary based on the specific substrate and scale.

II. 2-(tert-butoxycarbonyloxyimino)-2-phenylacetonitrile (Boc-ON): For Mild and Selective Protection

Boc-ON is a crystalline, stable reagent that offers an alternative to Boc_2O , particularly when milder reaction conditions are desired.

Mechanistic Rationale

The reaction with Boc-ON is also a nucleophilic acyl substitution. The amine attacks the carbonyl carbon of the Boc group, leading to the displacement of the oxime byproduct, 2-hydroxyimino-2-phenylacetonitrile. This byproduct is easily removed by extraction.

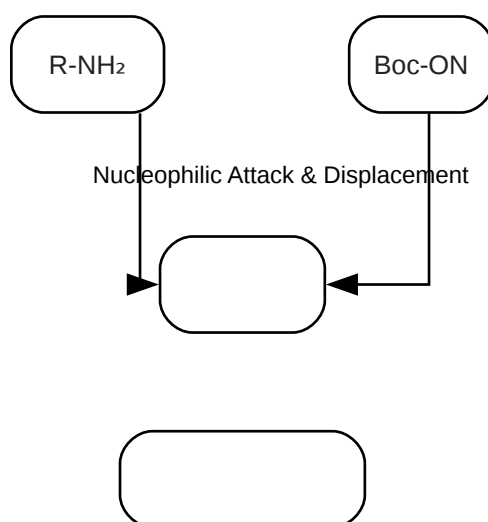

[Click to download full resolution via product page](#)

Boc Protection using Boc-ON.

Experimental Considerations and Data

Boc-ON is particularly useful for the protection of amino acids, often yielding clean products with minimal side reactions.

Typical Reaction Conditions:

- The reaction is typically carried out in aqueous dioxane or a similar solvent system with a mild base like triethylamine or sodium bicarbonate.

Substrate Type	Reagent System	Solvent	Temp. (°C)	Time (h)	Yield (%)
Amino Acid	Boc-ON, TEA	Dioxane/H ₂ O	RT	2-12	90-98
Primary Amine	Boc-ON, NaHCO ₃	Acetone/H ₂ O	RT	4-16	85-95

Note: Data is compiled from typical laboratory procedures and may vary.

III. tert-Butyl Chloroformate (Boc-Cl): A Highly Reactive but Less Stable Option

tert-Butyl chloroformate is a more reactive acylating agent compared to Boc₂O and Boc-ON. However, its instability and hazardous nature make it a less common choice.^[8]

Mechanistic Rationale

The mechanism is a straightforward nucleophilic acyl substitution where the amine attacks the carbonyl carbon of the chloroformate, displacing the chloride ion. A base is required to neutralize the HCl generated.

Experimental Considerations and Data

Due to its high reactivity, Boc-Cl can be useful for protecting sterically hindered or electronically deactivated amines. However, it is thermally unstable and must be handled with care at low temperatures.^[8]

Typical Reaction Conditions:

- Reactions are typically run at low temperatures (0 °C) in an inert solvent like THF or ether with a non-nucleophilic base.

Substrate Type	Reagent System	Solvent	Temp. (°C)	Time (h)	Yield (%)	Reference
Hindered Secondary Amine	Boc-Cl, DIPEA	THF	0 to RT	2-4	70-85	[8]

Note: Due to its instability, yields can be variable.

Comparative Summary

Feature	Di-tert-butyl Dicarbonate (Boc ₂ O)	2-(tert-butoxycarbonyloxy imino)-2-phenylacetonitrile (Boc-ON)	tert-Butyl Chloroformate (Boc-Cl)
Reactivity	High	Moderate	Very High
Stability	Stable solid/liquid	Stable crystalline solid	Thermally unstable liquid
Byproducts	t-BuOH, CO ₂ (gaseous)	Water-soluble oxime	HCl (corrosive)
Workup	Generally simple	Simple extraction	Requires careful neutralization
Primary Use	General purpose, wide applicability	Amino acids, mild conditions	Hindered/deactivated amines
Safety	Irritant, handle in a fume hood	Irritant, handle with care	Corrosive, toxic, handle with extreme care at low temperatures

Experimental Protocols

Protocol 1: General Procedure for Boc Protection using Boc₂O

- Dissolve the amine (1.0 equiv) in a suitable solvent (e.g., a 1:1 mixture of dioxane and water, or THF).
- Add the base (e.g., NaOH, 1.1 equiv, or TEA, 1.2 equiv).
- Add di-tert-butyl dicarbonate (1.1 equiv) portion-wise or as a solution in the reaction solvent.
- Stir the reaction mixture at room temperature for 2-12 hours, monitoring by TLC.
- Upon completion, remove the organic solvent under reduced pressure.
- Extract the aqueous residue with an organic solvent (e.g., ethyl acetate).
- Wash the combined organic layers with brine, dry over anhydrous sodium sulfate, and concentrate to afford the crude product.
- Purify by column chromatography if necessary.[9]

Protocol 2: Boc Protection of an Amino Acid using Boc-ON

- Dissolve the amino acid (1.0 equiv) in a 1:1 mixture of dioxane and water.
- Add triethylamine (2.0 equiv) and stir until the amino acid is dissolved.
- Add Boc-ON (1.05 equiv) and stir at room temperature for 4-12 hours.
- Monitor the reaction by TLC.
- Once complete, concentrate the reaction mixture to remove the dioxane.
- Dilute with water and wash with ether or ethyl acetate to remove the oxime byproduct.

- Acidify the aqueous layer to pH 2-3 with cold 1M HCl.
- Extract the product with ethyl acetate.
- Wash the combined organic layers with brine, dry over anhydrous sodium sulfate, and concentrate to yield the N-Boc protected amino acid.

Protocol 3: Boc Protection using tert-Butyl Chloroformate

Caution: tert-Butyl chloroformate is unstable and should be handled with care at low temperatures in a well-ventilated fume hood.

- Dissolve the amine (1.0 equiv) and a non-nucleophilic base such as DIPEA (1.5 equiv) in anhydrous THF under an inert atmosphere (N₂ or Ar).
- Cool the solution to 0 °C in an ice bath.
- Slowly add a solution of tert-butyl chloroformate (1.1 equiv) in THF dropwise.
- Allow the reaction mixture to warm to room temperature and stir for 2-4 hours, monitoring by TLC.
- Upon completion, quench the reaction with a saturated aqueous solution of ammonium chloride.
- Extract the product with an organic solvent.
- Wash the combined organic layers with water and brine, dry over anhydrous sodium sulfate, and concentrate.
- Purify by column chromatography.^[8]

Conclusion and Recommendations

The choice of a Boc-protection method is a critical decision in the planning of a synthetic route.

- Di-tert-butyl dicarbonate (Boc₂O) remains the reagent of choice for most applications due to its high efficiency, ease of use, and the benign nature of its byproducts. Its versatility across a wide range of reaction conditions makes it the go-to reagent for both routine and challenging protections.
- 2-(tert-butoxycarbonyloxyimino)-2-phenylacetonitrile (Boc-ON) serves as an excellent alternative, particularly in peptide synthesis where mild conditions and clean reactions are paramount. The ease of removal of its byproduct is a significant advantage.
- tert-Butyl chloroformate (Boc-Cl) should be reserved for specific cases where high reactivity is required to protect sterically hindered or electronically deactivated amines that are unreactive towards Boc₂O or Boc-ON. Its instability and hazardous nature necessitate careful handling and make it less suitable for general use.

By understanding the mechanistic nuances, reactivity profiles, and practical considerations of each method, researchers can make informed decisions to optimize their synthetic strategies, leading to higher yields, improved purity, and more efficient workflows in their drug discovery and development efforts.

References

- Organic Chemistry Portal. Boc-Protected Amino Groups. [\[Link\]](#)
- Ashenhurst, J. (2018). Protecting Groups for Amines: Carbamates. Master Organic Chemistry. [\[Link\]](#)
- Ragnarsson, U., & Grehn, L. (2013). Dual protection of amino functions involving Boc. RSC Advances, 3(35), 14894-14909. [\[Link\]](#)
- Beilstein Journals. (2011). EXPERIMENTAL PROCEDURES. [\[Link\]](#)
- Common Organic Chemistry. Boc Protection Mechanism (Boc₂O). [\[Link\]](#)
- Ashenhurst, J. (2020). Amine Protection and Deprotection. Master Organic Chemistry. [\[Link\]](#)
- Ben-Mesbah, K., et al. (2015). N-tert-Butoxycarbonylation of Structurally Diverse Amines and Sulfamides under Water-Mediated Catalyst-Free Conditions. International Journal of Organic

Chemistry, 5, 1-9. [[Link](#)]

- ACS Green Chemistry Institute Pharmaceutical Roundtable. BOC Deprotection. [[Link](#)]
- Chemistry Steps. Boc Protecting Group for Amines. [[Link](#)]

Need Custom Synthesis?

BenchChem offers custom synthesis for rare earth carbides and specific isotopic labeling.

Email: info@benchchem.com or [Request Quote Online](#).

Sources

- 1. Amine Protection / Deprotection [fishersci.co.uk]
- 2. [youtube.com](https://www.youtube.com) [[youtube.com](https://www.youtube.com)]
- 3. Boc-Protected Amino Groups [organic-chemistry.org]
- 4. masterorganicchemistry.com [masterorganicchemistry.com]
- 5. Boc Protection Mechanism (Boc2O) [commonorganicchemistry.com]
- 6. masterorganicchemistry.com [masterorganicchemistry.com]
- 7. Dual protection of amino functions involving Boc - RSC Advances (RSC Publishing) DOI:10.1039/C3RA42956C [pubs.rsc.org]
- 8. pdf.benchchem.com [pdf.benchchem.com]
- 9. beilstein-journals.org [beilstein-journals.org]
- To cite this document: BenchChem. [A Comparative Analysis of Boc-Protection Methods for Amine Functional Groups]. BenchChem, [2026]. [Online PDF]. Available at: [<https://www.benchchem.com/product/b1603712/docs#a-comparative-analysis-of-boc-protection-methods-for-amine-functional-groups>]

Disclaimer & Data Validity:

The information provided in this document is for Research Use Only (RUO) and is strictly not intended for diagnostic or therapeutic procedures. While BenchChem strives to provide

accurate protocols, we make no warranties, express or implied, regarding the fitness of this product for every specific experimental setup.

Technical Support: The protocols provided are for reference purposes. Unsure if this reagent suits your experiment?

Need Industrial/Bulk Grade? [Request Custom Synthesis Quote](#)

BenchChem

Our mission is to be the trusted global source of essential and advanced chemicals, empowering scientists and researchers to drive progress in science and industry.

Contact

Address: 3281 E Guasti Rd

Ontario, CA 91761, United States

Phone: (601) 213-4426

Email: info@benchchem.com

[Contact our Ph.D. Support Team for a compatibility check](#)