

# Pharmacological Profile of $\beta$ -Belladonnine: A Technical Guide

**Author:** BenchChem Technical Support Team. **Date:** April 2026

## Compound of Interest

Compound Name: *Belladonnine, beta-*

CAS No.: 6696-63-5

Cat. No.: B1602880

[Get Quote](#)

For Researchers, Scientists, and Drug Development Professionals

## Abstract

$\beta$ -Belladonnine, a tropane alkaloid found in plants of the Solanaceae family, exhibits a distinct pharmacological profile primarily characterized by its interaction with cholinergic receptors. This technical guide provides a comprehensive overview of the known pharmacological properties of  $\beta$ -belladonnine, including its receptor binding characteristics and functional effects. While specific quantitative in vitro data such as binding affinities ( $K_i$ ) and functional potencies ( $EC_{50}/IC_{50}$ ) for  $\beta$ -belladonnine are not extensively available in publicly accessible literature, this document synthesizes the existing in vivo data and provides context through comparison with the well-characterized belladonna alkaloids, atropine and scopolamine. Furthermore, this guide outlines detailed experimental protocols for the in vitro characterization of compounds like  $\beta$ -belladonnine and illustrates the key signaling pathways associated with its targets.

## Introduction

$\beta$ -Belladonnine is a naturally occurring alkaloid that has been identified as a component of various Solanaceae species. Its chemical structure, a tropane ester, is shared with other well-

known anticholinergic agents. The primary mechanism of action for  $\beta$ -belladonnine is the blockade of muscarinic acetylcholine receptors (mAChRs). Notably, it displays a degree of selectivity, with a more potent effect on cardiac M2 receptors compared to those in smooth muscle and glandular tissues.[1] At higher concentrations,  $\beta$ -belladonnine also demonstrates antagonist activity at nicotinic acetylcholine receptors (nAChRs).[1] A derivative,  $\beta$ -belladonnine dichloroethylate, has been reported to act as a short-acting muscle relaxant, possessing both M2- and N-cholinolytic properties, as well as antihistaminic activity.

This guide aims to provide a detailed technical resource for researchers and drug development professionals interested in the pharmacological profile of  $\beta$ -belladonnine. It summarizes the available quantitative data, presents detailed methodologies for its further study, and visualizes the relevant biological pathways.

## Quantitative Pharmacological Data

While specific in vitro binding and functional potency data for  $\beta$ -belladonnine are limited, the following tables summarize the available in vivo data for  $\beta$ -belladonnine and provide comparative in vitro data for the structurally related and well-studied belladonna alkaloids, atropine and scopolamine, to offer a contextual pharmacological framework.

Table 1: In Vivo Efficacy of  $\beta$ -Belladonnine

Parameter	Species	Tissue/Effect	Value	Reference
ED50	Not Specified	Heart M-receptor blockade	13 $\mu$ g/kg	[1]
ED50	Not Specified	Skeletal muscle N-cholinoreceptor blockade	50-60 mg/kg	[1]

Table 2: Comparative Muscarinic Receptor Binding Affinities of Related Belladonna Alkaloids

Compound	Receptor Subtype	Ki (nM)	Species	Reference
Atropine	M1	0.8 - 2.5	Human/Rat	
	M2	0.7 - 2.1	Human/Rat	
	M3	0.8 - 2.0	Human/Rat	
	M4	1.0 - 2.5	Human/Rat	
	M5	1.5 - 3.0	Human	
Scopolamine	M1	0.3 - 1.0	Human/Rat	
	M2	0.4 - 1.2	Human/Rat	
	M3	0.5 - 1.5	Human/Rat	
	M4	0.8 - 2.0	Human/Rat	
	M5	1.0 - 2.5	Human	

Note: The Ki values for atropine and scopolamine are compiled from various sources and represent a general range. Specific values can vary based on experimental conditions.

Table 3: Comparative Functional Antagonism of Related Belladonna Alkaloids at Muscarinic Receptors

Compound	Receptor Subtype	Assay Type	pA2 / IC50	Species	Reference
Atropine	M1	Phosphoinositide turnover	~9.0	Rat	
M2	Inhibition of adenylyl cyclase	~9.2	Rat		
M3	Contraction of smooth muscle	~9.5	Guinea Pig		
Scopolamine	M1	Phosphoinositide turnover	~9.3	Rat	
M2	Inhibition of adenylyl cyclase	~9.4	Rat		
M3	Contraction of smooth muscle	~9.7	Guinea Pig		

Note: pA2 is the negative logarithm of the molar concentration of an antagonist that produces a two-fold shift to the right in an agonist's concentration-response curve. IC50 values are highly dependent on the agonist concentration used.

## Experimental Protocols

The following protocols describe standard methodologies for determining the receptor binding affinity and functional activity of a compound like  $\beta$ -belladonnine at muscarinic acetylcholine receptors.

## Radioligand Binding Assay for Muscarinic Receptor Affinity

This protocol describes a competitive radioligand binding assay to determine the binding affinity ( $K_i$ ) of  $\beta$ -belladonnine for muscarinic M2 receptors using cell membranes from Chinese Hamster Ovary (CHO) cells stably expressing the human M2 receptor and [ $^3$ H]-N-methylscopolamine ([ $^3$ H]-NMS) as the radioligand.

#### Materials:

- CHO cell membranes expressing human M2 muscarinic receptors
- [ $^3$ H]-N-methylscopolamine ([ $^3$ H]-NMS)
- $\beta$ -Belladonnine
- Atropine (for non-specific binding determination)
- Assay Buffer: 50 mM Tris-HCl, 5 mM MgCl<sub>2</sub>, pH 7.4
- Scintillation cocktail
- Glass fiber filters
- Cell harvester
- Scintillation counter

#### Procedure:

- Membrane Preparation: Thaw the CHO-M2 cell membranes on ice and resuspend in ice-cold Assay Buffer to a final protein concentration of 20-40  $\mu$ g/mL. Homogenize briefly to ensure a uniform suspension.
- Assay Plate Preparation: In a 96-well plate, add Assay Buffer,  $\beta$ -belladonnine at various concentrations (e.g.,  $10^{-11}$  to  $10^{-5}$  M), and the radioligand [ $^3$ H]-NMS at a final concentration equal to its  $K_d$  (e.g.,  $\sim 0.5$  nM).
- Total and Non-Specific Binding: For total binding wells, add Assay Buffer instead of the competitor. For non-specific binding wells, add a high concentration of atropine (e.g., 1  $\mu$ M).

- Incubation: Add the prepared cell membrane suspension to each well to initiate the binding reaction. Incubate the plate at room temperature for 60-90 minutes with gentle agitation to reach equilibrium.
- Harvesting: Terminate the assay by rapid filtration through glass fiber filters using a cell harvester. Wash the filters three times with ice-cold Assay Buffer to remove unbound radioligand.
- Scintillation Counting: Place the filters in scintillation vials, add scintillation cocktail, and allow to equilibrate. Measure the radioactivity in a scintillation counter.
- Data Analysis: Calculate the specific binding by subtracting the non-specific binding from the total binding. Determine the IC50 value of  $\beta$ -belladonnine from the competition curve using non-linear regression. Calculate the Ki value using the Cheng-Prusoff equation:  $K_i = IC_{50} / (1 + [L]/K_d)$ , where [L] is the concentration of the radioligand and  $K_d$  is its dissociation constant.

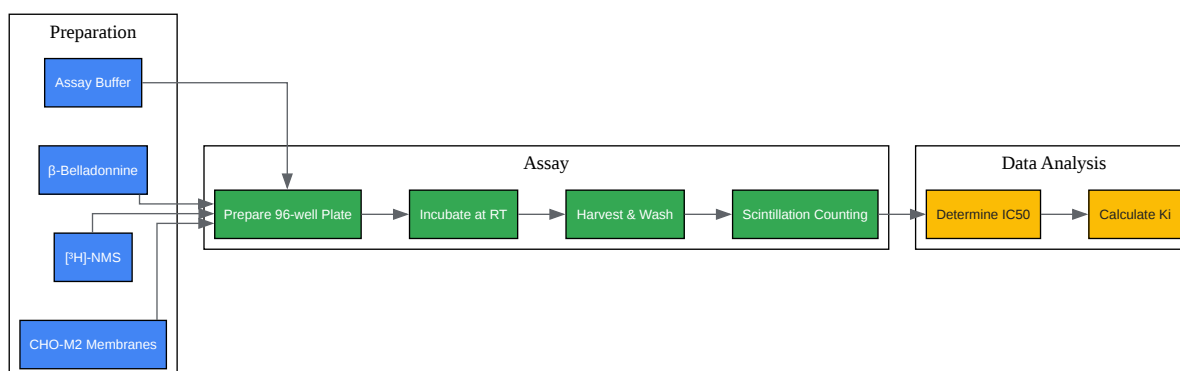

[Click to download full resolution via product page](#)

*Workflow for Radioligand Binding Assay.*

## Calcium Flux Functional Assay

This protocol describes a fluorescent-based functional assay to measure the antagonist effect of  $\beta$ -belladonnine on M3 muscarinic receptor-mediated calcium mobilization in CHO cells stably expressing the human M3 receptor.

### Materials:

- CHO cells stably expressing human M3 muscarinic receptors
- Cell culture medium (e.g., DMEM/F12)
- Calcium-sensitive fluorescent dye (e.g., Fluo-4 AM)
- Pluronic F-127
- Assay Buffer (e.g., Hanks' Balanced Salt Solution with 20 mM HEPES)
- Carbachol (agonist)
- $\beta$ -Belladonnine
- Fluorescence plate reader with automated injection capabilities

### Procedure:

- **Cell Plating:** Seed the CHO-M3 cells into black-walled, clear-bottom 96-well plates and culture overnight to form a confluent monolayer.
- **Dye Loading:** Prepare a loading solution of Fluo-4 AM and Pluronic F-127 in Assay Buffer. Remove the culture medium from the cells and add the dye loading solution. Incubate for 45-60 minutes at 37°C in the dark.
- **Compound Incubation:** After incubation, wash the cells with Assay Buffer to remove excess dye. Add  $\beta$ -belladonnine at various concentrations and incubate for 15-30 minutes.
- **Measurement:** Place the plate in the fluorescence plate reader. Establish a stable baseline fluorescence reading.

- **Agonist Stimulation:** Inject a pre-determined concentration of carbachol (typically the EC80) into the wells and immediately begin recording the fluorescence intensity over time.
- **Data Analysis:** The change in fluorescence intensity reflects the change in intracellular calcium concentration. Determine the inhibitory effect of  $\beta$ -belladonnine on the carbachol-induced calcium signal. Calculate the IC50 value from the concentration-response curve.

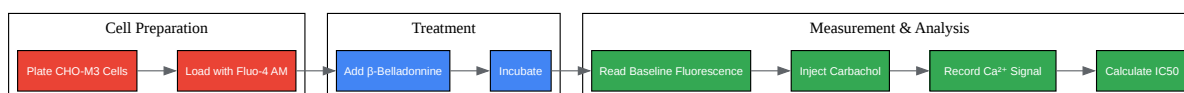

[Click to download full resolution via product page](#)

*Workflow for Calcium Flux Functional Assay.*

## Signaling Pathways

$\beta$ -Belladonnine exerts its effects by antagonizing muscarinic acetylcholine receptors, which are G-protein coupled receptors (GPCRs). The five subtypes of muscarinic receptors (M1-M5) couple to different G-proteins and initiate distinct intracellular signaling cascades.

### Gq/11-Coupled Muscarinic Receptors (M1, M3, M5)

Antagonism of M1, M3, and M5 receptors by  $\beta$ -belladonnine blocks the canonical Gq/11 signaling pathway. Upon agonist binding, these receptors activate phospholipase C (PLC), which hydrolyzes phosphatidylinositol 4,5-bisphosphate (PIP<sub>2</sub>) into inositol 1,4,5-trisphosphate (IP<sub>3</sub>) and diacylglycerol (DAG). IP<sub>3</sub> binds to its receptors on the endoplasmic reticulum, leading to the release of intracellular calcium stores. DAG, along with calcium, activates protein kinase C (PKC), which phosphorylates various downstream targets.

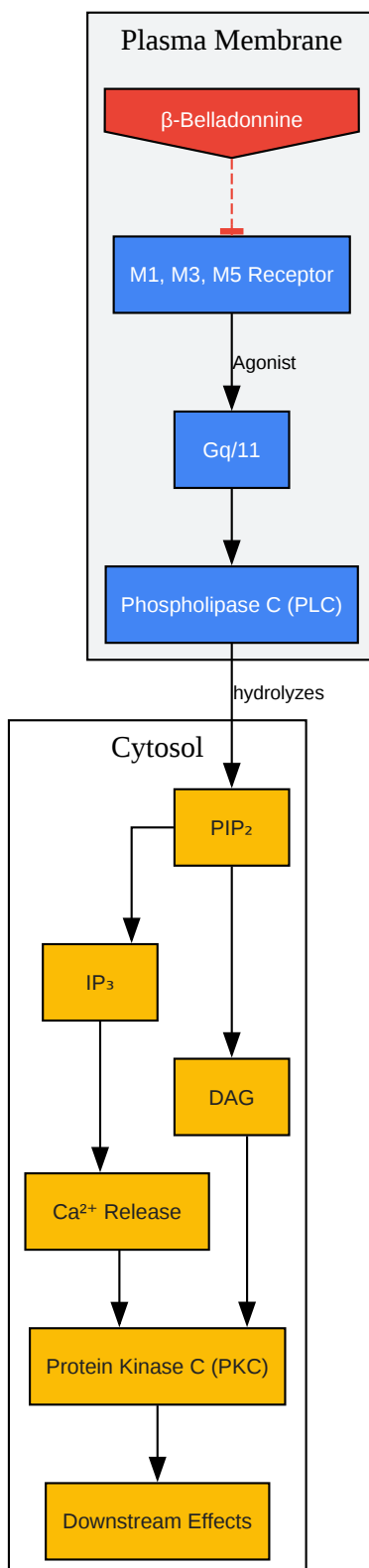

[Click to download full resolution via product page](#)

*Gq/11-Coupled Muscarinic Receptor Signaling Pathway.*

## Gi/o-Coupled Muscarinic Receptors (M2, M4)

$\beta$ -Belladonnine's antagonism of M2 and M4 receptors inhibits the Gi/o signaling pathway. Agonist activation of these receptors leads to the inhibition of adenylyl cyclase, resulting in decreased intracellular cyclic AMP (cAMP) levels and reduced protein kinase A (PKA) activity. The  $\beta\gamma$  subunits of the Gi/o protein can also directly modulate ion channels, such as G-protein-gated inwardly rectifying potassium (GIRK) channels, leading to membrane hyperpolarization.

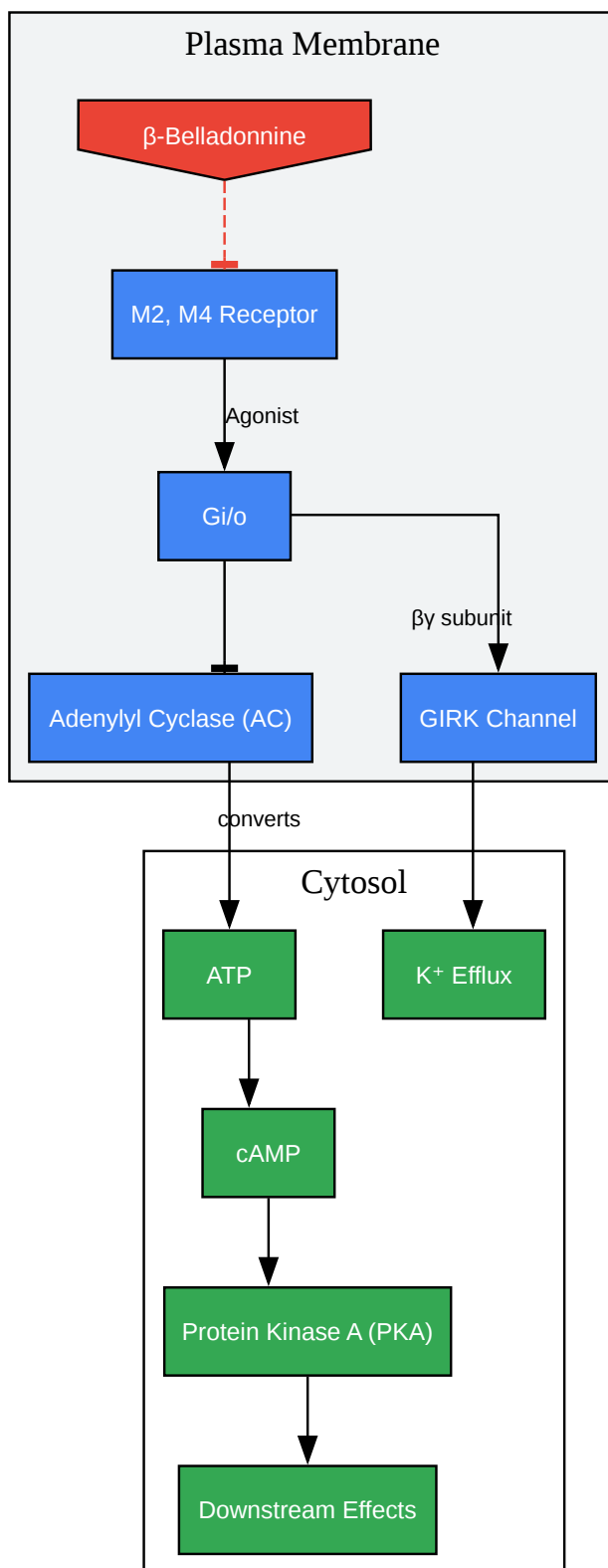

[Click to download full resolution via product page](#)

*Gi/o-Coupled Muscarinic Receptor Signaling Pathway.*

## Pharmacokinetics and Pharmacodynamics

Detailed pharmacokinetic studies specifically on  $\beta$ -belladonnine are not widely reported. As a tropane alkaloid, it is expected to be well-absorbed and distributed throughout the body, similar to atropine and scopolamine. The pharmacodynamics of  $\beta$ -belladonnine are a direct consequence of its anticholinergic properties. The selective blockade of cardiac M2 receptors at lower doses suggests a potential for cardiovascular effects, such as an increase in heart rate, with less pronounced effects on smooth muscle and glands.[1] At higher doses, the blockade of nicotinic receptors in skeletal muscle can lead to muscle weakness or paralysis.[1] The central nervous system effects are also anticipated, given the ability of tropane alkaloids to cross the blood-brain barrier.

## Conclusion

$\beta$ -Belladonnine is a tropane alkaloid with a pharmacological profile centered on the antagonism of muscarinic and, at higher concentrations, nicotinic acetylcholine receptors. Its selectivity for cardiac M2 receptors presents an interesting area for further investigation. While there is a scarcity of specific in vitro quantitative data, the methodologies and signaling pathway information provided in this guide offer a robust framework for future research and development efforts. A thorough characterization of its binding affinities, functional potencies, and pharmacokinetic properties is warranted to fully elucidate its therapeutic potential and toxicological profile.

### *Need Custom Synthesis?*

*BenchChem offers custom synthesis for rare earth carbides and specific isotopic labeling.*

*Email: [info@benchchem.com](mailto:info@benchchem.com) or [Request Quote Online](#).*

## References

- [1. medkoo.com \[medkoo.com\]](https://www.medkoo.com)
- To cite this document: BenchChem. [Pharmacological Profile of  $\beta$ -Belladonnine: A Technical Guide]. BenchChem, [2026]. [Online PDF]. Available at: [<https://www.benchchem.com/product/b1602880/docs#pharmacological-profile-of-belladonnine-a-technical-guide>]

**Disclaimer & Data Validity:**

The information provided in this document is for Research Use Only (RUO) and is strictly not intended for diagnostic or therapeutic procedures. While BenchChem strives to provide accurate protocols, we make no warranties, express or implied, regarding the fitness of this product for every specific experimental setup.

**Technical Support:** The protocols provided are for reference purposes. Unsure if this reagent suits your experiment?

**Need Industrial/Bulk Grade?** [Request Custom Synthesis Quote](#)

## BenchChem

Our mission is to be the trusted global source of essential and advanced chemicals, empowering scientists and researchers to drive progress in science and industry.

### Contact

Address: 3281 E Guasti Rd  
Ontario, CA 91761, United States  
Phone: (601) 213-4426  
Email: [info@benchchem.com](mailto:info@benchchem.com)

[Contact our Ph.D. Support Team for a compatibility check](#)