

Introduction: Decoding the Protective Interface with Electrochemical Impedance Spectroscopy

Author: BenchChem Technical Support Team. **Date:** May 2026

Compound of Interest

Compound Name: 3-Decylpyridine

CAS No.: 59652-33-4

Cat. No.: B1602177

[Get Quote](#)

Electrochemical Impedance Spectroscopy (EIS) stands as a powerful, non-destructive technique for the quantitative evaluation of protective films and coatings at the metal-electrolyte interface.[1][2][3] Unlike direct current (DC) methods, EIS applies a small amplitude alternating current (AC) signal over a wide range of frequencies to probe the system's impedance.[4][5] This approach allows for the detailed characterization of various electrochemical processes, including charge transfer kinetics, film resistance, and dielectric properties, making it exceptionally valuable in the development and screening of corrosion inhibitors.[2]

Among the vast array of corrosion inhibitors, organic molecules, particularly those capable of forming self-assembled monolayers, have garnered significant attention. Pyridine derivatives, for instance, are known to be effective inhibitors for various metals in acidic media.[6][7] This guide provides a comprehensive comparison of **3-decylpyridine** films against other relevant alternatives, grounded in the principles and experimental data of EIS. We will delve into the causality behind experimental choices, present detailed protocols for trustworthy and repeatable measurements, and visualize the underlying processes to provide a holistic understanding for researchers, scientists, and professionals in the field.

The Protective Mechanism of 3-Decylpyridine Films

The efficacy of **3-decylpyridine** as a corrosion inhibitor stems from its amphiphilic molecular structure, which facilitates strong adsorption onto a metal surface, creating a protective barrier. This process is twofold:

- **Chemisorption via the Pyridine Head:** The pyridine ring, with its nitrogen heteroatom and delocalized π -electrons, acts as the anchor. The nitrogen atom can coordinate with vacant d-orbitals of the metal atoms, while the π -electron system can also interact with the metal surface, leading to a stable, chemically adsorbed layer.^{[8][9][10]} This is a form of chemisorption, where a true chemical bond is formed between the molecule and the surface.^[11]
- **Hydrophobic Barrier via the Decyl Tail:** Extending from the pyridine head is the ten-carbon alkyl chain (decyl group). This long, non-polar tail orients itself away from the metal surface and, through van der Waals interactions with adjacent molecules, forms a dense, tightly packed hydrophobic layer.^{[6][12]} This layer acts as a physical barrier, displacing water and aggressive ions (like Cl^- and H^+) from the surface, thereby stifling the electrochemical corrosion reactions.

The overall adsorption process is often a synergistic combination of chemisorption and physisorption, which can be modeled by adsorption isotherms like the Langmuir model to quantify the surface coverage.^{[5][12][13]}

The Expected EIS Signature

When a metal surface is effectively protected by a **3-decylpyridine** film, its EIS spectrum exhibits distinct changes compared to a bare, corroding surface:

- **Nyquist Plot:** The plot of imaginary impedance ($-Z''$) versus real impedance (Z') for a bare metal in a corrosive solution typically shows a single, small semicircle. The diameter of this semicircle corresponds to the charge transfer resistance (R_{ct}), which is inversely proportional to the corrosion rate. Upon the formation of a **3-decylpyridine** film, the semicircle's diameter increases significantly, indicating a much higher R_{ct} and, consequently, a lower corrosion rate.^{[4][14][15]}

- Bode Plot: This plot shows the impedance modulus ($|Z|$) and phase angle versus frequency. For an effective inhibitor film, the $|Z|$ value at low frequencies will be substantially higher than that of the bare metal.[15] The phase angle plot will also show a broader peak or a shift to lower frequencies, indicative of the protective film's capacitive behavior.
- Double-Layer Capacitance (Cdl): The formation of the inhibitor film displaces water molecules and alters the dielectric properties of the metal-electrolyte interface. This leads to a decrease in the double-layer capacitance (Cdl), a value that can be extracted from the EIS data.[13][14]

Comparative Analysis: 3-Decylpyridine vs. Alternative Inhibitors

To contextualize the performance of **3-decylpyridine**, it is essential to compare it with structurally similar molecules. The primary factors influencing inhibitor performance are the nature of the adsorbing head group and the length of the hydrophobic alkyl chain. For this guide, we will compare **3-decylpyridine** with two other N-alkyl pyridinium compounds, one with a shorter alkyl chain (C8) and one with a longer chain (C12), to illustrate the critical role of the hydrophobic barrier.

Inhibitor	Structure	Key EIS Parameter	Value (Illustrative)	Inhibition Efficiency (IE%)
Blank (No Inhibitor)	N/A	Charge Transfer Resistance (Rct)	50 $\Omega \cdot \text{cm}^2$	0%
Double-Layer Capacitance (Cdl)	150 $\mu\text{F} \cdot \text{cm}^{-2}$			
N-(n-octyl)-3-methylpyridinium (C8-Py)[12]	Pyridine head, C8 alkyl tail	Charge Transfer Resistance (Rct)	415 $\Omega \cdot \text{cm}^2$	87.9%
Double-Layer Capacitance (Cdl)	45 $\mu\text{F} \cdot \text{cm}^{-2}$			
3-Decylpyridine (C10-Py)	Pyridine head, C10 alkyl tail	Charge Transfer Resistance (Rct)	750 $\Omega \cdot \text{cm}^2$	93.3%
Double-Layer Capacitance (Cdl)	32 $\mu\text{F} \cdot \text{cm}^{-2}$			
N-(n-dodecyl)-3-methylpyridinium (C12-Py)[6][12]	Pyridine head, C12 alkyl tail	Charge Transfer Resistance (Rct)	980 $\Omega \cdot \text{cm}^2$	94.9%
Double-Layer Capacitance (Cdl)	25 $\mu\text{F} \cdot \text{cm}^{-2}$			

Note: The values in this table are illustrative, based on typical trends reported in the literature, to demonstrate comparative performance. Actual values are highly dependent on specific experimental conditions.

Analysis of Performance Trends:

As demonstrated in the table, the addition of any of the inhibitors leads to a significant increase in charge transfer resistance (R_{ct}) and a decrease in double-layer capacitance (C_{dl}) compared to the blank solution.[13][16] This confirms the formation of a protective film on the metal surface.

Crucially, a clear trend emerges with increasing alkyl chain length:

- R_{ct} increases from the C8 to the C12 derivative. This is because a longer alkyl chain allows for stronger van der Waals forces between adjacent molecules, leading to a more densely packed, ordered, and stable hydrophobic film that more effectively blocks the charge transfer process of corrosion.
- C_{dl} decreases as the alkyl chain gets longer. A longer chain creates a thicker dielectric layer at the interface, which, according to the Helmholtz model, results in lower capacitance.

This data strongly supports the conclusion that while **3-decylpyridine** is a highly effective inhibitor, its performance can be further enhanced by increasing the length of the alkyl tail, as seen with the dodecyl (C12) analogue.

Experimental Protocol for EIS Evaluation of Pyridine-Based Inhibitors

This section provides a self-validating, step-by-step protocol for performing EIS measurements to screen and compare corrosion inhibitors.

1. Materials and Electrode Preparation

- Working Electrode (WE): Mild steel or API 5L X60 carbon steel coupons with a fixed exposed surface area (e.g., 1.0 cm²).[14][16]
- Reference Electrode (RE): Saturated Calomel Electrode (SCE).[1][5][14]
- Counter Electrode (CE): Platinum wire or graphite rod with a surface area significantly larger than the WE.[1][14]
- Preparation of WE: Before each experiment, the working electrode must be mechanically polished using a series of silicon carbide (SiC) papers of decreasing grit size (e.g., 600, 800,

1200 grit). This is followed by rinsing with deionized water and degreasing with acetone or ethanol. The electrode should then be dried immediately. This rigorous preparation ensures a reproducible surface state for each measurement.

2. Electrolyte and Inhibitor Solutions

- Corrosive Medium: Prepare a 1 M HCl solution or a 3.5% NaCl solution using analytical grade reagents and deionized water.[5][13][17]
- Inhibitor Solutions: Prepare a stock solution of **3-decylpyridine** and its analogues. The final test solutions should be made by adding the required volume of the stock solution to the corrosive medium to achieve a specific concentration range (e.g., 50 ppm to 250 ppm).[18]

3. Electrochemical Measurement Setup and Procedure

- Cell Assembly: Assemble the three electrodes in a standard electrochemical cell (e.g., PARC cell) containing the test solution.[14] Ensure the Luggin capillary of the reference electrode is positioned close to the working electrode surface to minimize IR drop.
- Stabilization: Immerse the electrodes in the solution and allow the system to stabilize by monitoring the Open Circuit Potential (E_{corr}) until it reaches a steady state (typically 30-60 minutes).[1][5] This ensures the measurement is performed on a system at equilibrium.
- EIS Measurement:
 - Perform the EIS measurement at the stabilized E_{corr} .
 - Apply a small sinusoidal AC voltage perturbation of 10 mV (peak to peak).[5] This small amplitude ensures a linear system response without significantly disturbing the corrosion process.
 - Scan a frequency range from 100 kHz down to 10 mHz.[1][2][5] The high-frequency data provides information about the solution resistance, while the low-frequency data reveals information about the charge transfer and film formation processes.

4. Data Analysis and Interpretation

- Equivalent Circuit Modeling: Use appropriate software (e.g., ZView, CorrWare) to fit the experimental EIS data to an Equivalent Electrical Circuit (EEC).[2][19] This allows for the extraction of quantitative parameters like R_s , R_{ct} , and CPE.
- Calculation of Inhibition Efficiency (IE%): The inhibition efficiency can be calculated from the charge transfer resistance values using the following equation: $IE\% = [(R_{ct}(inh) - R_{ct}(blank)) / R_{ct}(inh)] \times 100$ Where $R_{ct}(inh)$ is the charge transfer resistance in the presence of the inhibitor and $R_{ct}(blank)$ is the charge transfer resistance in the blank solution.

Visualization of Experimental Workflow and Data Modeling

Diagrams created using Graphviz provide a clear visual representation of the processes involved.

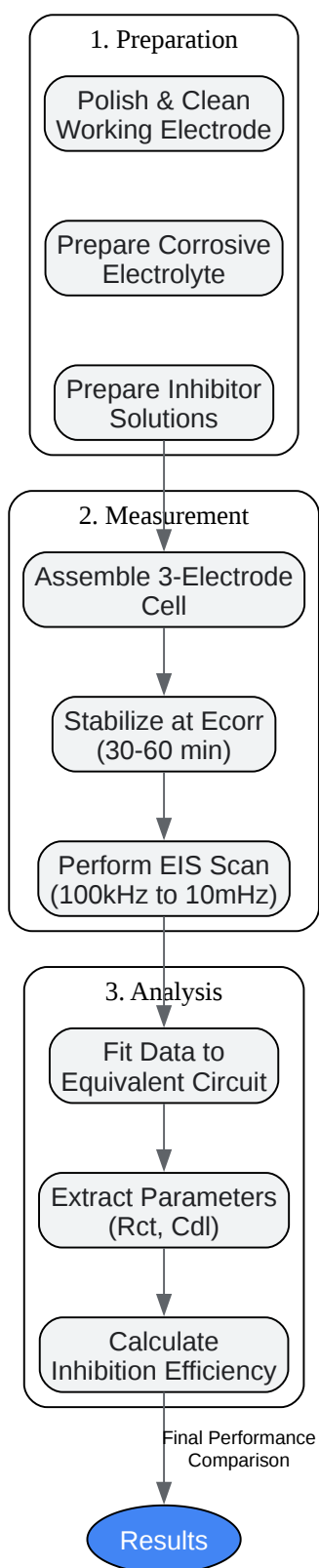

[Click to download full resolution via product page](#)

Caption: Experimental workflow for EIS analysis of corrosion inhibitors.

Equivalent Electrical Circuit (EEC) Models

EECs are used to model the electrochemical interface.[19][20] For corrosion systems, a simple Randles circuit is often used for the blank, while a more complex model is needed for the inhibitor-protected surface.

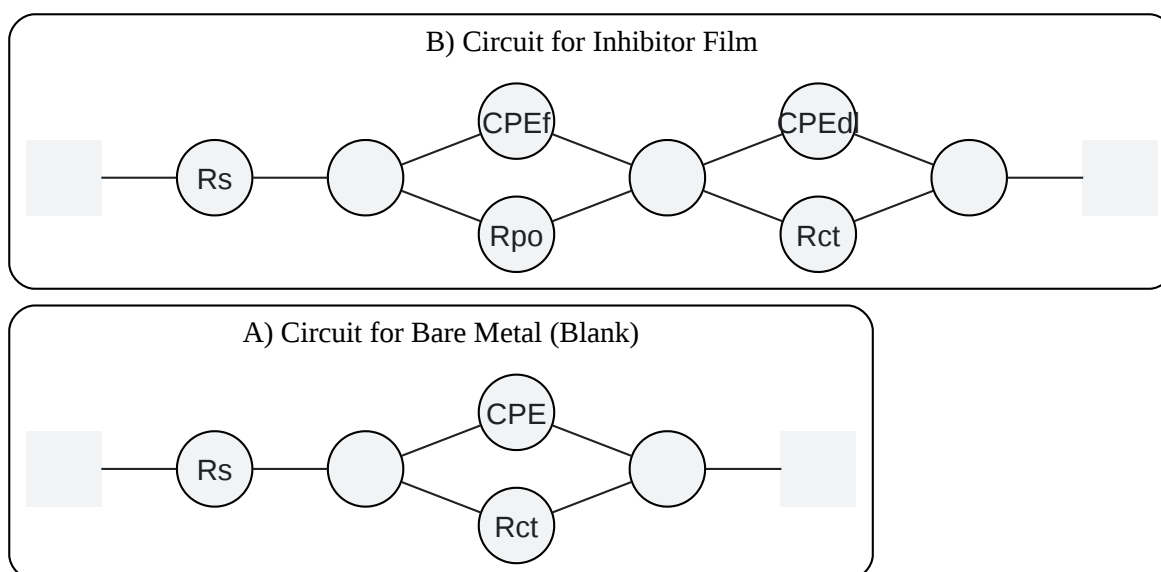

[Click to download full resolution via product page](#)

Caption: Equivalent circuits for (A) bare metal and (B) inhibitor film.

In these models:

- R_s : Solution resistance.
- R_{ct} : Charge transfer resistance.
- CPE: Constant Phase Element, used instead of a pure capacitor to account for surface inhomogeneities. It represents the double-layer capacitance (CPE_d) or film capacitance (CPE_f).
- R_{po} (or R_f): Pore resistance of the inhibitor film.

Conclusion

Electrochemical Impedance Spectroscopy provides an exceptionally detailed and quantitative method for evaluating the performance of corrosion inhibitors like **3-decylpyridine**. The experimental data clearly demonstrates that **3-decylpyridine** forms a highly effective protective film on metal surfaces, significantly increasing the charge transfer resistance and lowering the double-layer capacitance.

Comparative analysis reveals a critical structure-activity relationship: the length of the hydrophobic alkyl chain is directly correlated with inhibition efficiency. Longer chains, such as in N-(n-dodecyl)-3-methylpyridinium, create a more robust and impermeable barrier, offering superior protection compared to **3-decylpyridine** (C10) and its shorter-chain (C8) analogues. This guide provides the foundational understanding and practical protocols for researchers to conduct reliable, comparative studies, accelerating the development of next-generation corrosion inhibitors.

References

- Application of electrochemical impedance spectroscopy technology to evaluate passivation performance of film forming and adsorption types corrosion inhibitors. (2022). International Journal of Corrosion and Scale Inhibition, 11(3), 1303–1318.
- Muth, J., et al. (2023). Incorporating Physics-Based Models into Equivalent Circuit Analysis of EIS Data from Organic Coatings. MDPI. [\[Link\]](#)
- Kamarudin, M. H. (2014). EXPERIMENTAL ANALYSIS OF COMPATIBILITY BETWEEN CORROSION INHIBITOR AND BIOCIDES USING ELECTROCHEMICAL IMPEDANCE SPECTROSCOPY. Universiti Teknologi PETRONAS. [\[Link\]](#)
- Mahmud, S., et al. (2018). Competing adsorption mechanisms of pyridine on Cu, Ag, Au, and Pt(110) surfaces. Physical Review B, 98(23). [\[Link\]](#)
- Mourya, P., et al. (2014). Study of corrosion inhibition by Electrochemical Impedance Spectroscopy method of 5083 aluminum alloy in 1M HCl solution conta. ResearchGate. [\[Link\]](#)
- Juarez-Hernandez, J., et al. (2010). Electrochemical Impedance Spectroscopy (EIS) Study of the Film Formation of 2-imidazoline Derivatives on Carbon Steel in Acid S. Materials

Science. [\[Link\]](#)

- López, D. A., et al. (2004). Inhibitors performance in CO₂ corrosion EIS studies on the interaction between their molecular structure and steel microstructur. CONICET. [\[Link\]](#)
- Kumar, S., et al. (2022). Corrosion Inhibition Investigation of Small Organic Inhibitor on API5LX60 Steel in 3.5% NaCl Solution with CO₂ Saturation. Research Square. [\[Link\]](#)
- Equivalent circuit model used to fit EIS data. ResearchGate. [\[Link\]](#)
- Mahmud, S., et al. (2018). Competing adsorption mechanisms of pyridine on Cu, Ag, Au, and Pt(110) surfaces. arXiv. [\[Link\]](#)
- Luo, F., et al. (2025). Alkyl pyridine ionic liquid as a green corrosion inhibitor for mild steel in acidic medium. Semantic Scholar. [\[Link\]](#)
- Singh, P., et al. (2021). Comparative Studies on the Corrosion Inhibition of Three Different Organic Heterocyclic Compounds as Corrosion Inhibitors for Mild Steel in Hydrochloric Acid. SciELO. [\[Link\]](#)
- Luo, F., et al. (2025). Alkyl pyridine ionic liquid as a green corrosion inhibitor for mild steel in acidic medium. RSC Advances. [\[Link\]](#)
- Naz, F., et al. (2022). Evaluating the Corrosion Inhibition Efficiency of Pyridinium-Based Cationic Surfactants for EN3B Mild Steel in Acidic-Chloride Media. ResearchGate. [\[Link\]](#)
- Mechanism of adsorption of [C12Py]Br molecules on Fe surfaces. ResearchGate. [\[Link\]](#)
- Steinkühler, J., et al. (2020). On the Integration of Dielectrometry into Electrochemical Impedance Spectroscopy to Obtain Characteristic Properties of a Dielectric Thin Film. arXiv. [\[Link\]](#)
- Cesiulis, H., et al. (2016). The Study of Thin Films by Electrochemical Impedance Spectroscopy. OUCI. [\[Link\]](#)
- Liu, J., et al. (2010). Structural characterization of self-assembled monolayers of pyridine-terminated thiolates on gold. Physical Chemistry Chemical Physics, 12(17), 4459-72. [\[Link\]](#)

- Gu, Z., et al. (2001). Electrochemical Impedance Spectroscopy Study on A3 Steel in Anti-corrosive Pigment Extract Solution. *Journal of Electrochemistry*, 7(3), 345-350. [[Link](#)]
- Liu, J., et al. (2010). Structural characterization of self-assembled monolayers of pyridine-terminated thiolates on gold. *ResearchGate*. [[Link](#)]
- Liu, H., et al. (2021). First Principle Analysis on Pyridine Amide Derivatives' Adsorption Behavior on the Pt (111) Surface. *MDPI*. [[Link](#)]
- The Use of Electrochemical Impedance Spectroscopy as a Screening Method for Determination of Hydrolytic Stability of Poly(ethyl 2-cyanoacrylate). *MDPI*. [[Link](#)]
- Liu, J., et al. (2010). Structural characterization of self-assembled monolayers of pyridine-terminated thiolates on gold. *PubMed*. [[Link](#)]
- Adsorption of Molecules onto Metallic Surfaces. The University of Vermont. [[Link](#)]
- El-Aziz, K. A. (2006). Electrochemical Impedance Spectroscopy Study of the Corrosion Behavior of Some Niobium Bearing Stainless Steels in 3.5% NaCl. *International Journal of Electrochemical Science*, 1, 169-179. [[Link](#)]
- Mendes, S. B., et al. (2004). Characterization of self-assembled thiols monolayers on gold surface by electrochemical impedance spectroscopy. *ResearchGate*. [[Link](#)]
- Di Tocco, T., et al. (2022). Electrochemical and X-ray Photoelectron Spectroscopy Surface Characterization of Interchain-Driven Self-Assembled Monolayer (SAM) Reorganization. *MDPI*. [[Link](#)]

Need Custom Synthesis?

BenchChem offers custom synthesis for rare earth carbides and specific isotopic labeling.

Email: info@benchchem.com or [Request Quote Online](#).

Sources

- 1. ijcsi.pro [ijcsi.pro]

- [2. corrosion.metrohmusa.com](https://corrosion.metrohmusa.com) [corrosion.metrohmusa.com]
- [3. electrochemsci.org](https://electrochemsci.org) [electrochemsci.org]
- [4. utpedia.utp.edu.my](https://utpedia.utp.edu.my) [utpedia.utp.edu.my]
- [5. jmaterenvironsci.com](https://jmaterenvironsci.com) [jmaterenvironsci.com]
- [6. pdfs.semanticscholar.org](https://pdfs.semanticscholar.org) [pdfs.semanticscholar.org]
- 7. Alkyl pyridine ionic liquid as a green corrosion inhibitor for mild steel in acidic medium - RSC Advances (RSC Publishing) [pubs.rsc.org]
- [8. researchgate.net](https://researchgate.net) [researchgate.net]
- 9. Competing adsorption mechanisms of pyridine on Cu, Ag, Au, and Pt(110) surfaces - PubMed [pubmed.ncbi.nlm.nih.gov]
- [10. mdpi.com](https://mdpi.com) [mdpi.com]
- 11. Adsorption of Molecules onto Metallic Surfaces [uvm.edu]
- [12. researchgate.net](https://researchgate.net) [researchgate.net]
- 13. Comparative Studies on the Corrosion Inhibition of Three Different Organic Heterocyclic Compounds as Corrosion Inhibitors for Mild Steel in Hydrochloric Acid [scielo.org.mx]
- [14. matsc.ktu.lt](https://matsc.ktu.lt) [matsc.ktu.lt]
- [15. ri.conicet.gov.ar](https://ri.conicet.gov.ar) [ri.conicet.gov.ar]
- [16. biointerfaceresearch.com](https://biointerfaceresearch.com) [biointerfaceresearch.com]
- [17. jelectrochem.xmu.edu.cn](https://jelectrochem.xmu.edu.cn) [jelectrochem.xmu.edu.cn]
- [18. researchgate.net](https://researchgate.net) [researchgate.net]
- [19. mdpi.com](https://mdpi.com) [mdpi.com]
- 20. Electrochemical Impedance Spectroscopy (EIS) Part 4 – Equivalent Circuit Models | Metrohm [metrohm.com]
- To cite this document: BenchChem. [Introduction: Decoding the Protective Interface with Electrochemical Impedance Spectroscopy]. BenchChem, [2026]. [Online PDF]. Available at: [<https://www.benchchem.com/product/b1602177/docs#introduction-decoding-the-protective-interface-with-electrochemical-impedance-spectroscopy>]

Disclaimer & Data Validity:

The information provided in this document is for Research Use Only (RUO) and is strictly not intended for diagnostic or therapeutic procedures. While BenchChem strives to provide accurate protocols, we make no warranties, express or implied, regarding the fitness of this product for every specific experimental setup.

Technical Support: The protocols provided are for reference purposes. Unsure if this reagent suits your experiment?

Need Industrial/Bulk Grade? [Request Custom Synthesis Quote](#)

BenchChem

Our mission is to be the trusted global source of essential and advanced chemicals, empowering scientists and researchers to drive progress in science and industry.

Contact

Address: 3281 E Guasti Rd
Ontario, CA 91761, United States
Phone: (601) 213-4426
Email: info@benchchem.com

[Contact our Ph.D. Support Team for a compatibility check](#)