

# Application Note: Synthesis of Quinoline Intermediates via Vilsmeier-Haack Cyclization

**Author:** BenchChem Technical Support Team. **Date:** April 2026

## Compound of Interest

Compound Name: *2-Chloro-3-chloromethyl-8-methylquinoline*

CAS No.: 948291-50-7

Cat. No.: B1602579

[Get Quote](#)

## Introduction & Strategic Context

The Vilsmeier-Haack (VH) reaction is a cornerstone methodology for the formylation of electron-rich aromatic systems. When applied to N-arylamides (acetanilides), the reaction undergoes a specialized cascade known as the Meth-Cohn quinoline synthesis, yielding 2-chloro-3-formylquinolines[1]. These bifunctionalized quinolines are highly prized intermediates in medicinal chemistry, serving as versatile scaffolds for the development of antimalarial, antibacterial, and anticancer therapeutics[2].

As a Senior Application Scientist, I emphasize that this transformation is not a simple substitution but a complex, multi-step cascade. Success relies heavily on precise stoichiometric control, thermal management, and an understanding of the underlying electrophilic dynamics.

## Mechanistic Causality & Workflow

To master this protocol, one must understand the causality behind the reagent choices. The reaction relies on the *in situ* generation of the Vilsmeier reagent—a highly electrophilic

chloroiminium salt formed by the reaction of N,N-Dimethylformamide (DMF) and phosphorus oxychloride ( $\text{POCl}_3$ )[2].

The Meth-Cohn cyclization demands a double formylation[3]. The first equivalent of the VH reagent attacks the activated methyl group of the acetamide moiety, while the second targets the aromatic ring. Subsequent intramolecular cyclization at elevated temperatures closes the pyridine ring, and the elimination of dimethylamine coupled with chloride incorporation completes the aromatization.

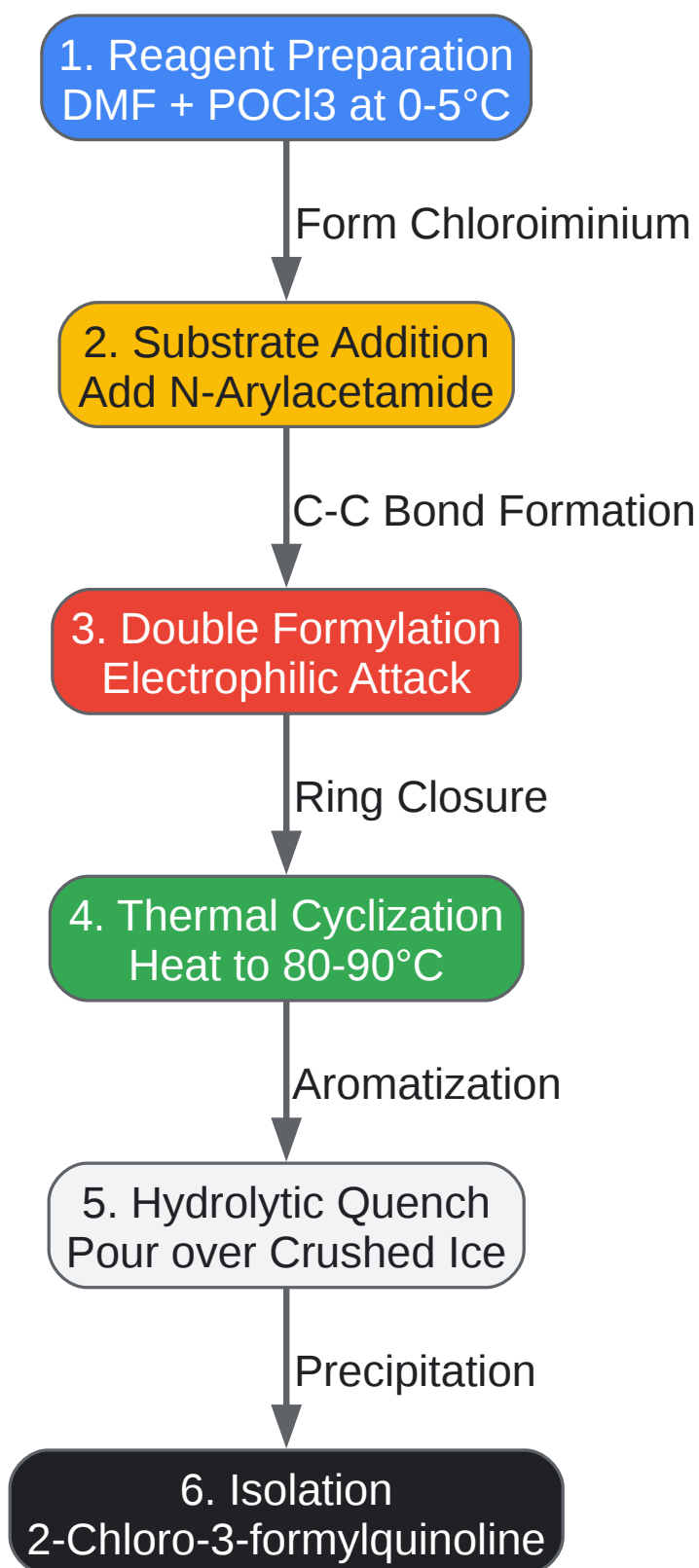

[Click to download full resolution via product page](#)

Step-by-step workflow of the Vilsmeier-Haack quinoline synthesis.

## Quantitative Optimization

The stoichiometry of POCl<sub>3</sub> is the most critical variable. While a standard formylation requires only a slight excess of the VH reagent, the Meth-Cohn cyclization demands a massive excess. POCl<sub>3</sub> acts as both the activating agent and the solvent matrix to drive the equilibrium of the double formylation. Empirical data demonstrates that an optimal ratio of 12 equivalents of POCl<sub>3</sub> to 1 equivalent of acetanilide maximizes the yield.

Table 1: Optimization of POCl<sub>3</sub> Equivalents and Temperature for Acetanilide Cyclization

POCl <sub>3</sub> (Equivalents)	Temperature (°C)	Time (h)	Yield (%)	Mechanistic Observation
3.0	80	16	< 20	Incomplete conversion; mono-formylation stalls.
7.0	90	12	45	Intermediate accumulation; sluggish cyclization.
12.0	90	8	> 85	Optimal double formylation and rapid ring closure.
15.0	100	8	60	Substrate degradation; significant tar formation.

## Experimental Protocol: Synthesis of 2-Chloro-3-formylquinoline

This protocol is designed as a self-validating system. Visual cues and analytical checkpoints are embedded to ensure experimental integrity.

## Materials Required:

- N-Arylacetamide (Acetanilide derivative) (1.0 eq)
- Anhydrous N,N-Dimethylformamide (DMF) (3.0 eq)
- Phosphorus oxychloride ( $\text{POCl}_3$ ) (12.0 eq)
- Crushed ice and saturated  $\text{Na}_2\text{CO}_3$  or NaOH solution

## Step-by-Step Methodology:

- Reagent Generation (The Exothermic Phase): In a flame-dried round-bottom flask under an inert argon atmosphere, add dry DMF (3.0 eq). Cool the flask to 0–5 °C using an ice-water bath. Dropwise, add  $\text{POCl}_3$  (12.0 eq) under vigorous stirring.
  - Causality: The reaction between DMF and  $\text{POCl}_3$  is highly exothermic. Dropwise addition controls the exotherm, preventing the thermal degradation of the highly reactive chloroiminium salt.
  - Validation: The solution will transition from colorless to a pale yellow, viscous liquid, confirming successful Vilsmeier reagent formation[4].
- Substrate Addition: Stir the freshly prepared VH reagent for 30 minutes at 0 °C. Slowly add the N-arylacetamide (1.0 eq) in small portions.
  - Causality: Portion-wise addition prevents localized heating and controls the initial electrophilic attack on the activated methyl group[4].
- Thermal Cyclization: Equip the flask with a reflux condenser and heat the mixture to 80–90 °C for 4 to 16 hours (substrate dependent).
  - Validation: The reaction mixture will darken significantly (often deep red or brown). Monitor the reaction via Thin Layer Chromatography (TLC) using an Ethyl Acetate:Hexane (3:7) solvent system. The disappearance of the highly polar acetanilide spot and the emergence of a UV-active, less polar spot indicates successful conversion[4].

- Hydrolytic Quench: Once complete, cool the mixture to room temperature. Slowly pour the mixture over a large excess of vigorously stirred crushed ice.
  - Causality: The ice serves a critical dual purpose: it safely dissipates the massive heat generated by the hydrolysis of excess  $\text{POCl}_3$ , and it unmasks the intermediate iminium species, hydrolyzing it into the final aldehyde group[5].
- Isolation & Basification: The resulting aqueous mixture will be highly acidic. Slowly neutralize the mixture with saturated sodium carbonate or sodium hydroxide until a pH of 7–8 is reached.
  - Causality: The quinoline product is basic and will remain soluble as a protonated quinolinium salt in acidic media. Basification is mandatory to precipitate the free 2-chloro-3-formylquinoline[5].
- Purification: Filter the crude yellow/brown precipitate under vacuum, wash thoroughly with cold distilled water, and dry. Recrystallize the crude product from ethanol or ethyl acetate. If impurities persist, purify via silica gel column chromatography[4].

## Troubleshooting & Field Insights

- Issue: Formation of dark, tarry side products.
  - Cause: Overheating ( $>100\text{ }^\circ\text{C}$ ) or unnecessarily prolonged reaction times lead to polymerization and degradation[4].
  - Solution: Strictly monitor the reaction via TLC. Do not exceed  $90\text{ }^\circ\text{C}$  unless the substrate is highly deactivated.
- Issue: No precipitate forms upon pouring over ice.
  - Cause: The aqueous layer is too acidic, keeping the quinoline trapped in the aqueous phase as a water-soluble quinolinium salt[5].
  - Solution: Ensure complete basification (pH 8) using NaOH or  $\text{Na}_2\text{CO}_3$ . The product will immediately crash out of solution once the correct pH is achieved[5].
- Issue: Low yield with electron-withdrawing groups (EWGs).

- Cause: EWGs on the aniline ring deactivate the aromatic system, raising the activation energy required for the second electrophilic attack and subsequent cyclization.
- Solution: Utilize micellar media (e.g., CTAB surfactants)[6] or transition metal catalysts (such as Cu(II) or Ni(II)) to stabilize the mixed ligand precursors, lower the activation energy, and enhance yields for deactivated substrates[7].

## References

- Vilsmeier-Haack reagent: A facile synthesis of 2-chloro-3-formylquinolines from N-arylacetamides and transformation - NIScPR. Available at: [\[Link\]](#)
- Kinetic and Mechanistic Study of Transition Metal Ion Catalyzed Vilsmeier–Haack Cyclization and Formylation Reactions with Acetanilides - Taylor & Francis. Available at:[\[Link\]](#)
- An Efficient and Facile Synthesis of 2-Chloro-3-formyl Quinolines from Acetanilides in Micellar Media by Vilsmeier-Haack Cyclisation - ResearchGate. Available at:[\[Link\]](#)
- Exploration of Synthetic Potential of Quinoline-3-Carbaldehydes - ResearchGate. Available at:[\[Link\]](#)
- Vilsmeier-Haack reaction for preparation of 2-chloro-3-formyl quinoline? - ResearchGate. Available at:[\[Link\]](#)
- Vilsmeier–Haack reaction of 7-acetyl-2-arylindoles: a convenient method for the synthesis of 6-oxo-6H-pyrrolo[3,2,1-ij]quinoline-1,5-dicarbaldehydes - Organic & Biomolecular Chemistry (RSC Publishing). Available at:[\[Link\]](#)

### Need Custom Synthesis?

BenchChem offers custom synthesis for rare earth carbides and specific isotopic labeling.

Email: [info@benchchem.com](mailto:info@benchchem.com) or [Request Quote Online](#).

## Sources

- 1. [researchgate.net](https://www.researchgate.net) [[researchgate.net](https://www.researchgate.net)]

- [2. pdf.benchchem.com \[pdf.benchchem.com\]](https://pdf.benchchem.com)
- [3. Vilsmeier–Haack reaction of 7-acetyl-2-arylindoles: a convenient method for the synthesis of 6-oxo-6H-pyrrolo\[3,2,1-ij\]quinoline-1,5-dicarbaldehydes - Organic & Biomolecular Chemistry \(RSC Publishing\) \[pubs.rsc.org\]](#)
- [4. benchchem.com \[benchchem.com\]](https://benchchem.com)
- [5. researchgate.net \[researchgate.net\]](https://researchgate.net)
- [6. researchgate.net \[researchgate.net\]](https://researchgate.net)
- [7. tandfonline.com \[tandfonline.com\]](https://tandfonline.com)
- To cite this document: BenchChem. [Application Note: Synthesis of Quinoline Intermediates via Vilsmeier-Haack Cyclization]. BenchChem, [2026]. [Online PDF]. Available at: [\[https://www.benchchem.com/product/b1602579/docs#application-note-synthesis-of-quinoline-intermediates-via-vilsmeier-haack-cyclization\]](https://www.benchchem.com/product/b1602579/docs#application-note-synthesis-of-quinoline-intermediates-via-vilsmeier-haack-cyclization)

---

#### Disclaimer & Data Validity:

The information provided in this document is for Research Use Only (RUO) and is strictly not intended for diagnostic or therapeutic procedures. While BenchChem strives to provide accurate protocols, we make no warranties, express or implied, regarding the fitness of this product for every specific experimental setup.

**Technical Support:** The protocols provided are for reference purposes. Unsure if this reagent suits your experiment?

**Need Industrial/Bulk Grade?** [Request Custom Synthesis Quote](#)

## BenchChem

Our mission is to be the trusted global source of essential and advanced chemicals, empowering scientists and researchers to drive progress in science and industry.

#### Contact

Address: 3281 E Guasti Rd  
Ontario, CA 91761, United States  
Phone: (601) 213-4426  
Email: [info@benchchem.com](mailto:info@benchchem.com)

Contact our Ph.D. Support Team for a compatibility check