

Application Note: High-Precision Synthesis of Furan-Modified Peptide-Drug Conjugates (PDCs)

Author: BenchChem Technical Support Team. **Date:** May 2026

Compound of Interest

Compound Name:	2-Amino-3-(furan-3-yl)propanoic acid
CAS No.:	3685-52-7
Cat. No.:	B1602126

[Get Quote](#)

Abstract

This application note details the synthesis of Peptide-Drug Conjugates (PDCs) utilizing furan-modified amino acids, specifically L-2-furylalanine (Fua). Unlike conventional cysteine (thiol-maleimide) or lysine (amine-NHS) conjugations, furan chemistry offers a distinct bio-orthogonal handle that enables two divergent modalities: (1) Diels-Alder (DA) cycloaddition for stable or thermally reversible conjugation, and (2) Oxidative activation for reactive crosslinking or prodrug strategies. This guide provides optimized Solid Phase Peptide Synthesis (SPPS) protocols, cleavage conditions to prevent furan degradation, and step-by-step conjugation workflows.

Chemical Basis & Strategic Advantages[1][2]

The incorporation of a furan moiety into a peptide backbone introduces an electron-rich diene system that is inert under physiological conditions but highly reactive under specific triggers.

The Two Modalities of Furan Chemistry

- Diels-Alder (DA) Ligation: The furan ring acts as a diene, reacting with a maleimide-functionalized drug (dienophile) to form a bicyclic adduct. This reaction is atom-efficient and can be reversible (retro-Diels-Alder) at elevated temperatures, offering a mechanism for controlled drug release [1].
- Oxidative Activation (PROS): Singlet oxygen () or chemical oxidants (e.g., NBS) convert the furan into a highly reactive keto-enal or aldehyde species. This intermediate can crosslink with nucleophiles (amines/thiols) on a target receptor or release a payload upon oxidative stress (ROS-triggered prodrugs) [2].

Mechanism Visualization

The following diagram illustrates the divergent pathways available for Furan-PDCs.

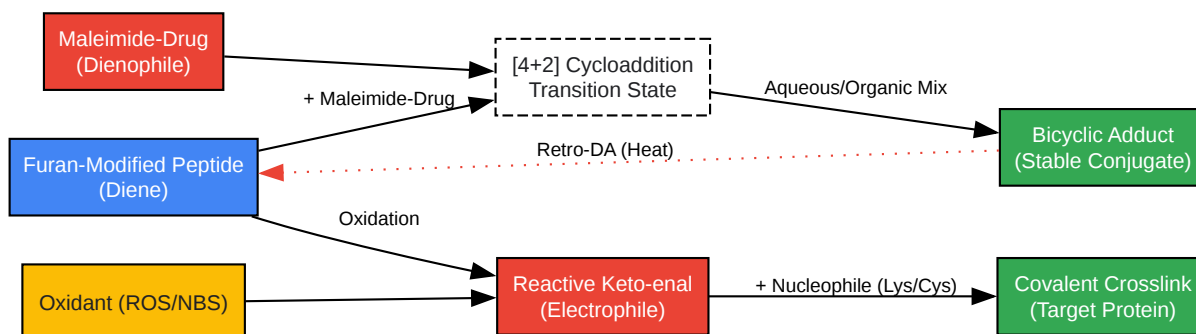

[Click to download full resolution via product page](#)

Figure 1: Divergent reaction pathways for furan-modified peptides. The Diels-Alder route is preferred for stable drug conjugation, while oxidation is used for activation or crosslinking.

Phase 1: Solid Phase Peptide Synthesis (SPPS)[3]

The synthesis of furan-peptides requires specific attention to acid stability during the cleavage phase. While the furan ring is generally stable to TFA, it is susceptible to alkylation by carbocations if improper scavengers are used.

Reagents

- Building Block: Fmoc-L-2-furylalanine (Fmoc-Fua-OH).
- Resin: Rink Amide (for C-term amides) or Wang Resin (for C-term acids).
- Coupling Agents: HBTU/DIPEA or DIC/Oxyma.

Protocol: Chain Assembly

- Swelling: Swell resin in DMF for 30 min.
- Deprotection: 20% Piperidine in DMF (2 x 5 min). Wash with DMF (5x).
- Coupling:
 - Dissolve Fmoc-Fua-OH (4 eq), HBTU (4 eq), and DIPEA (8 eq) in DMF.
 - Add to resin and shake for 45–60 min at room temperature.
 - Note: Fua couples with standard kinetics; double coupling is rarely necessary unless the sequence is difficult.
- Capping: Acetyl anhydride/Pyridine (optional, to truncate unreacted chains).

Critical Protocol: Resin Cleavage

WARNING: Do NOT use Ethanedithiol (EDT) or Propanedithiol. These scavengers react with the furan ring under acidic conditions, leading to degradation products [3].

Recommended Cleavage Cocktail (Reagent K modified):

Component	Volume Ratio	Function
TFA (Trifluoroacetic acid)	95%	Cleavage agent
TIS (Triisopropylsilane)	2.5%	Hydride donor/Scavenger
H2O	2.5%	Hydrolysis of protecting groups

| Optional:DODT | 2.5% | Alternative thiol scavenger (less aggressive to furan than EDT) |

Steps:

- Wash resin with DCM to remove DMF traces. Dry under N₂.
- Add Cleavage Cocktail (10 mL per g resin).
- Shake for 2–3 hours at room temperature.
- Precipitate filtrate in cold diethyl ether (-20°C).
- Centrifuge, wash pellet 2x with ether, and lyophilize.

Phase 2: Conjugation Protocols

Choose Method A for standard PDC synthesis (linking a drug to the peptide). Choose Method B if designing a ROS-responsive prodrug.

Method A: Diels-Alder Conjugation (Furan + Maleimide)

This method creates a stable linkage without catalyst.

Materials:

- Purified Furan-Peptide.
- Maleimide-functionalized Payload (e.g., Maleimide-Doxorubicin or Maleimide-PEG-Drug).
- Solvent: 50:50 mixture of PBS (pH 6.5) and Acetonitrile (ACN).

Protocol:

- Dissolution: Dissolve Furan-Peptide (1 mM final conc.) in the PBS/ACN mixture.
- Addition: Add Maleimide-Drug (1.5 – 2.0 equivalents).
 - Why Excess? Diels-Alder kinetics can be slow; excess dienophile drives the reaction.
- Incubation:

- Standard: Incubate at 37°C for 24–48 hours.
- Accelerated: If the peptide is thermally stable, incubate at 50°C for 6–12 hours.
- Note: The reaction is accelerated in water due to the hydrophobic effect, but organic co-solvent is usually needed for drug solubility.
- Monitoring: Monitor by HPLC. The product will be a mixture of exo and endo isomers (often appearing as split or broadened peaks).
- Purification: Purify via preparative RP-HPLC. Lyophilize.

Method B: Oxidative Activation (Prodrug/Crosslinking)

This method generates a reactive aldehyde for immediate capture or release.

Protocol (NBS Activation):

- Dissolve Furan-Peptide (100 μM) in Phosphate Buffer (pH 7.4).
- Add N-Bromosuccinimide (NBS) (1.0 eq).
 - Caution: Excess NBS will oxidize other residues (Met, Trp). Titrate carefully.
- Reaction is instantaneous (< 5 min). The furan converts to a keto-enal.
- Capture: Add the nucleophilic drug (hydrazine or amine functionalized) immediately.

Quality Control & Characterization

Validating the formation of the furan-conjugate requires specific analytical checks.

Analytical Workflow

- RP-HPLC:
 - Furan-Peptide: Distinct retention time.

- Conjugate: Shift in retention time. Note that DA adducts may show peak broadening due to isomer mixtures.
- Mass Spectrometry (ESI-MS):
 - Diels-Alder Product: Mass = [Peptide] + [Maleimide-Drug]. No water loss.
 - Oxidized Product: Mass = [Peptide] + 16 Da (Oxygen insertion) or ring opening variations depending on pH.

Self-Validating Check

To confirm the integrity of the furan ring before conjugation:

- Take a small aliquot of the purified peptide.
- Add 1 eq of NBS.
- Check MS.^[1] If the mass shifts by +16 Da (or +32 Da), the furan was intact. If no shift occurs, the furan may have degraded during SPPS cleavage.

Experimental Workflow Diagram

The following Graphviz diagram summarizes the complete operational workflow from resin to final PDC.

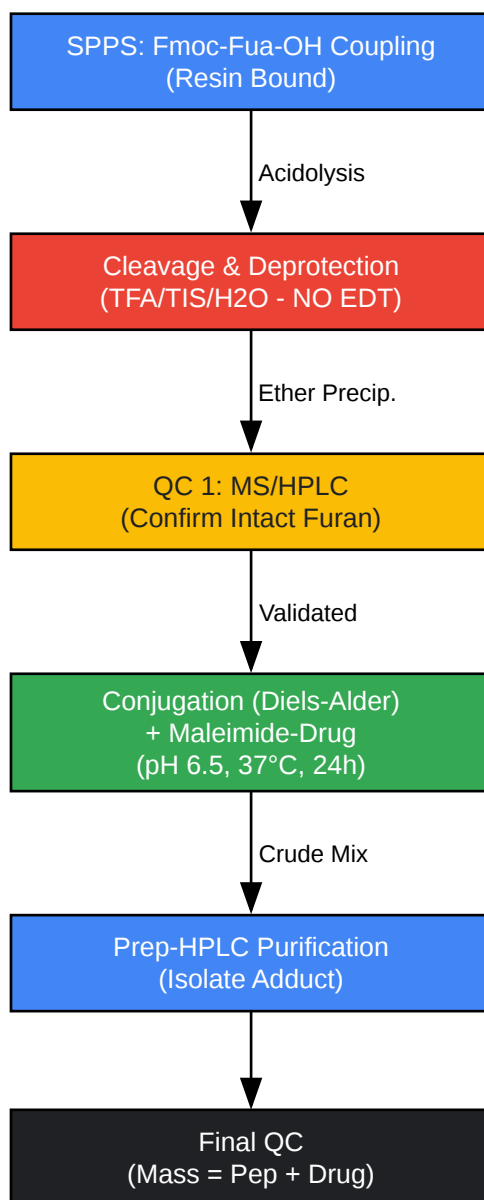

[Click to download full resolution via product page](#)

Figure 2: Step-by-step operational workflow for synthesizing Furan-PDCs.

References

- Diels–Alder Mediated Controlled Release from a Poly(ethylene glycol) Based Hydrogel. *Biomacromolecules*. (2013). Available at: [[Link](#)]
- Stability and cleavage conditions of (2-furyl)-L-alanine-containing peptides. *Protein & Peptide Letters*. (2004). Available at: [[Link](#)]

- From DNA cross-linking to peptide labeling: on the versatility of the furan-oxidation–conjugation strategy. *Chemical Communications*. (2009).^[1] Available at: [\[Link\]](#)

Need Custom Synthesis?

BenchChem offers custom synthesis for rare earth carbides and specific isotopic labeling.

Email: info@benchchem.com or [Request Quote Online](#).

Sources

- 1. From DNA cross-linking to peptide labeling: on the versatility of the furan-oxidation–conjugation strategy - *Chemical Communications* (RSC Publishing) [pubs.rsc.org]
- To cite this document: BenchChem. [Application Note: High-Precision Synthesis of Furan-Modified Peptide-Drug Conjugates (PDCs)]. BenchChem, [2026]. [Online PDF]. Available at: [<https://www.benchchem.com/product/b1602126/docs#application-note-high-precision-synthesis-of-furan-modified-peptide-drug-conjugates-pdcs>]

Disclaimer & Data Validity:

The information provided in this document is for Research Use Only (RUO) and is strictly not intended for diagnostic or therapeutic procedures. While BenchChem strives to provide accurate protocols, we make no warranties, express or implied, regarding the fitness of this product for every specific experimental setup.

Technical Support: The protocols provided are for reference purposes. Unsure if this reagent suits your experiment?

Need Industrial/Bulk Grade? [Request Custom Synthesis Quote](#)

BenchChem

Our mission is to be the trusted global source of essential and advanced chemicals, empowering scientists and researchers to drive progress in science and industry.

Contact

Address: 3281 E Guasti Rd

Ontario, CA 91761, United States

Phone: (601) 213-4426

Email: info@benchchem.com

[Contact our Ph.D. Support Team for a compatibility check](#)