

common side reactions in pyrazole ring formation and how to avoid them

Author: BenchChem Technical Support Team. **Date:** May 2026

Compound of Interest

Compound Name: ethyl 1-(4-bromophenyl)-5-cyano-1H-pyrazole-4-carboxylate

CAS No.: 98475-71-9

Cat. No.: B1601649

[Get Quote](#)

Pyrazole Ring Formation: A Technical Support Center for Researchers

Welcome to the technical support center for pyrazole ring formation. This guide is designed for researchers, scientists, and drug development professionals who are actively working with or troubleshooting pyrazole synthesis in their laboratories. As a senior application scientist with extensive experience in heterocyclic chemistry, I have compiled this resource to address the common—and often frustrating—side reactions encountered during pyrazole synthesis and to provide practical, field-proven solutions.

The formation of the pyrazole ring, a cornerstone in medicinal chemistry, is most frequently achieved through the condensation of a 1,3-dicarbonyl compound (or a synthetic equivalent) with a hydrazine derivative. While seemingly straightforward, this reaction is often plagued by a variety of side reactions that can significantly impact yield, purity, and even the identity of the final product. This guide is structured to help you diagnose and resolve these issues effectively.

Troubleshooting Guide: Navigating Common Side Reactions

This section is formatted as a series of common problems you might encounter in the lab, followed by their probable causes and actionable solutions.

Problem 1: My reaction produced a mixture of two isomers that are difficult to separate.

Probable Cause: The most common side reaction in pyrazole synthesis, when using an unsymmetrical 1,3-dicarbonyl compound, is the formation of regioisomers. The initial nucleophilic attack of the substituted hydrazine can occur at either of the two different carbonyl carbons, leading to two distinct pyrazole products.^[1]

Mechanism of Regioisomer Formation:

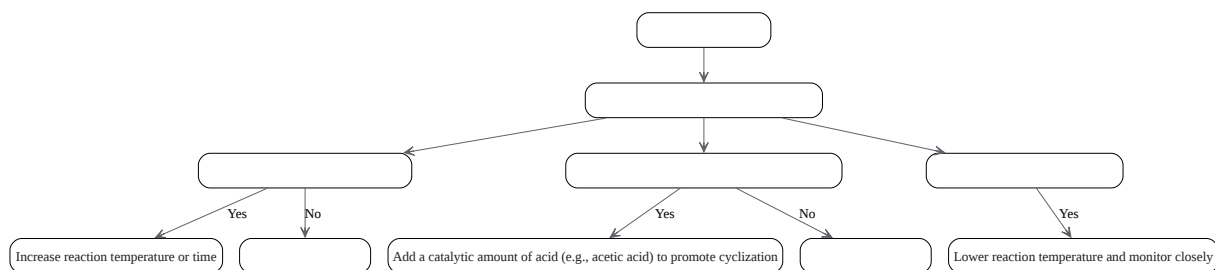
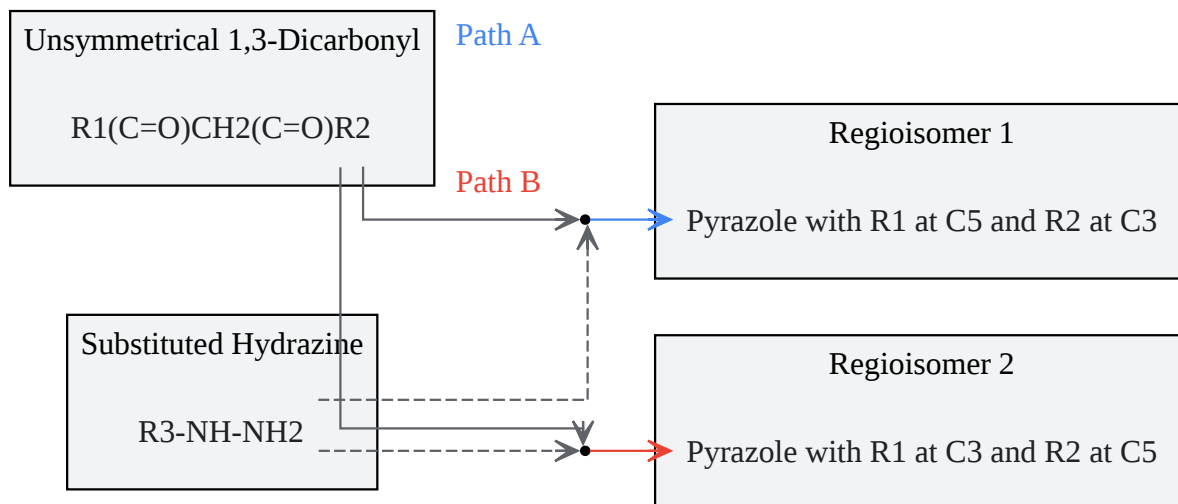

[Click to download full resolution via product page](#)

Need Custom Synthesis?

BenchChem offers custom synthesis for rare earth carbides and specific isotopic labeling.

Email: info@benchchem.com or [Request Quote Online](#).

Sources

- [1. benchchem.com \[benchchem.com\]](#)
- To cite this document: BenchChem. [common side reactions in pyrazole ring formation and how to avoid them]. BenchChem, [2026]. [Online PDF]. Available at: [\[https://www.benchchem.com/product/b1601649/docs#common-side-reactions-in-pyrazole-ring-formation-and-how-to-avoid-them\]](https://www.benchchem.com/product/b1601649/docs#common-side-reactions-in-pyrazole-ring-formation-and-how-to-avoid-them)

Disclaimer & Data Validity:

The information provided in this document is for Research Use Only (RUO) and is strictly not intended for diagnostic or therapeutic procedures. While BenchChem strives to provide accurate protocols, we make no warranties, express or implied, regarding the fitness of this product for every specific experimental setup.

Technical Support: The protocols provided are for reference purposes. Unsure if this reagent suits your experiment?

Need Industrial/Bulk Grade? [Request Custom Synthesis Quote](#)

BenchChem

Our mission is to be the trusted global source of essential and advanced chemicals, empowering scientists and researchers to drive progress in science and industry.

Contact

Address: 3281 E Guasti Rd
Ontario, CA 91761, United States
Phone: (601) 213-4426
Email: info@benchchem.com

[Contact our Ph.D. Support Team for a compatibility check](#)

