

Technical Support Center: Improving Regioselectivity in Imidazole Functionalization

Author: BenchChem Technical Support Team. **Date:** May 2026

Compound of Interest

Compound Name: *4,5-Dibromo-1,2-dimethyl-1H-imidazole*

CAS No.: 16954-05-5

Cat. No.: B102120

[Get Quote](#)

Welcome to the Technical Support Center for imidazole functionalization. This guide is designed for researchers, medicinal chemists, and drug development professionals who are navigating the complexities of achieving regiocontrol in their synthetic endeavors. The imidazole core is a privileged scaffold in numerous pharmaceuticals and functional materials, making the precise control over substituent placement a critical challenge.^{[1][2][3][4][5][6]} This resource provides in-depth, experience-driven troubleshooting guides, frequently asked questions (FAQs), and validated protocols to address common issues encountered in the lab.

I. Fundamental Principles Governing Regioselectivity

Understanding the inherent electronic and steric properties of the imidazole ring is paramount to controlling functionalization outcomes.

Q1: What are the key factors that determine the regioselectivity of imidazole functionalization?

A1: Regioselectivity in imidazole synthesis and functionalization is primarily dictated by a combination of three main factors:

- **Electronic Effects:** The imidazole ring possesses a unique electronic landscape. The C2 proton is the most acidic, making it susceptible to deprotonation, while the C5 position is generally electron-rich and prone to electrophilic attack.^[7] The two nitrogen atoms, N1 and N3, have similar reactivity, which often leads to mixtures of regioisomers during N-alkylation.^[7] The presence of electron-withdrawing or electron-donating groups on the ring can significantly alter this landscape. For example, an electron-withdrawing group at the C4(5) position can deactivate the adjacent N3 nitrogen, favoring functionalization at the more distant N1 position.^[7]
- **Steric Hindrance:** The size of substituents already present on the imidazole ring, as well as the bulk of the incoming reagent, plays a crucial role.^{[7][8]} Bulky groups will sterically shield adjacent positions, directing incoming reagents to less hindered sites. This is a common strategy to control regioselectivity in both N-alkylation and C-H functionalization.^{[7][9]}
- **Reaction Conditions:** The choice of solvent, base, catalyst, and temperature can dramatically influence the regiochemical outcome.^[7] For instance, in palladium-catalyzed C-H arylations of SEM-protected imidazole, switching from a carbonate base to a stronger alkoxide base can shift the selectivity from the C5 to the C2 position.^{[1][7]} Similarly, solvent polarity can affect the tautomeric equilibrium of the imidazole ring and the solvation of intermediates, thereby influencing the product ratio.^{[10][11]}

II. Troubleshooting Guide: Common Scenarios & Solutions

This section addresses specific problems that are frequently encountered during the functionalization of imidazoles.

Scenario 1: Poor Regioselectivity in N-Alkylation

Problem: "My N-alkylation reaction on an unsymmetrically substituted imidazole is yielding a nearly 1:1 mixture of N1 and N3 regioisomers. How can I improve the selectivity for a single isomer?"

Root Cause Analysis: This is a classic challenge in imidazole chemistry. The deprotonation of an unsymmetrical imidazole generates an ambident nucleophile where the negative charge is delocalized across both nitrogen atoms, leading to similar reactivity at both sites.[7]

Solutions & Troubleshooting Steps:

- Exploit Steric Hindrance:
 - Rationale: If one of the nitrogen atoms is sterically more accessible than the other, you can use a bulky alkylating agent to favor substitution at the less hindered position.[9]
 - Actionable Advice: If your current alkylating agent is small (e.g., methyl iodide), consider switching to a bulkier one (e.g., isopropyl bromide or benzyl bromide) if your synthetic scheme allows. Conversely, if the imidazole itself has a bulky substituent at C4(5), this will naturally direct alkylation towards the N1 position.
- Leverage Electronic Effects:
 - Rationale: The presence of an electron-withdrawing group (EWG) at the C4 or C5 position decreases the nucleophilicity of the adjacent N3 nitrogen, thus favoring alkylation at N1.[7]
 - Actionable Advice: If synthetically feasible, introduce an EWG (e.g., a nitro or cyano group) to direct the alkylation. This group can potentially be removed or modified in a subsequent step.
- Employ Protecting Groups:
 - Rationale: A protecting group can be used to block one of the nitrogen atoms, forcing the alkylation to occur at the other. This is one of the most reliable methods for achieving high regioselectivity.[9][12] The trityl (Tr) and (2-(trimethylsilyl)ethoxymethyl) (SEM) groups are particularly effective.[1][13]
 - Actionable Advice: Protect the imidazole with a bulky group like trityl chloride.[13] The trityl group will preferentially attach to the less hindered nitrogen, allowing for subsequent functionalization at the other nitrogen. The trityl group is acid-labile and can be removed under mild conditions.[13] The SEM group is another excellent choice that can direct C-H arylation and be removed later.[1][7]

- Optimize Reaction Conditions (Base and Solvent):
 - Rationale: The choice of base and solvent can influence the position of the tautomeric equilibrium and the nature of the ion pairing with the imidazolate anion, thereby affecting the N1/N3 ratio.[9]
 - Actionable Advice: Screen a variety of base/solvent combinations. For instance, using a strong base like sodium hydride (NaH) in an aprotic polar solvent like DMF or THF ensures complete deprotonation.[9] In contrast, using a weaker base like potassium carbonate (K_2CO_3) in acetonitrile may favor a different regioisomer.[9]

Decision Workflow for Improving N-Alkylation Selectivity:

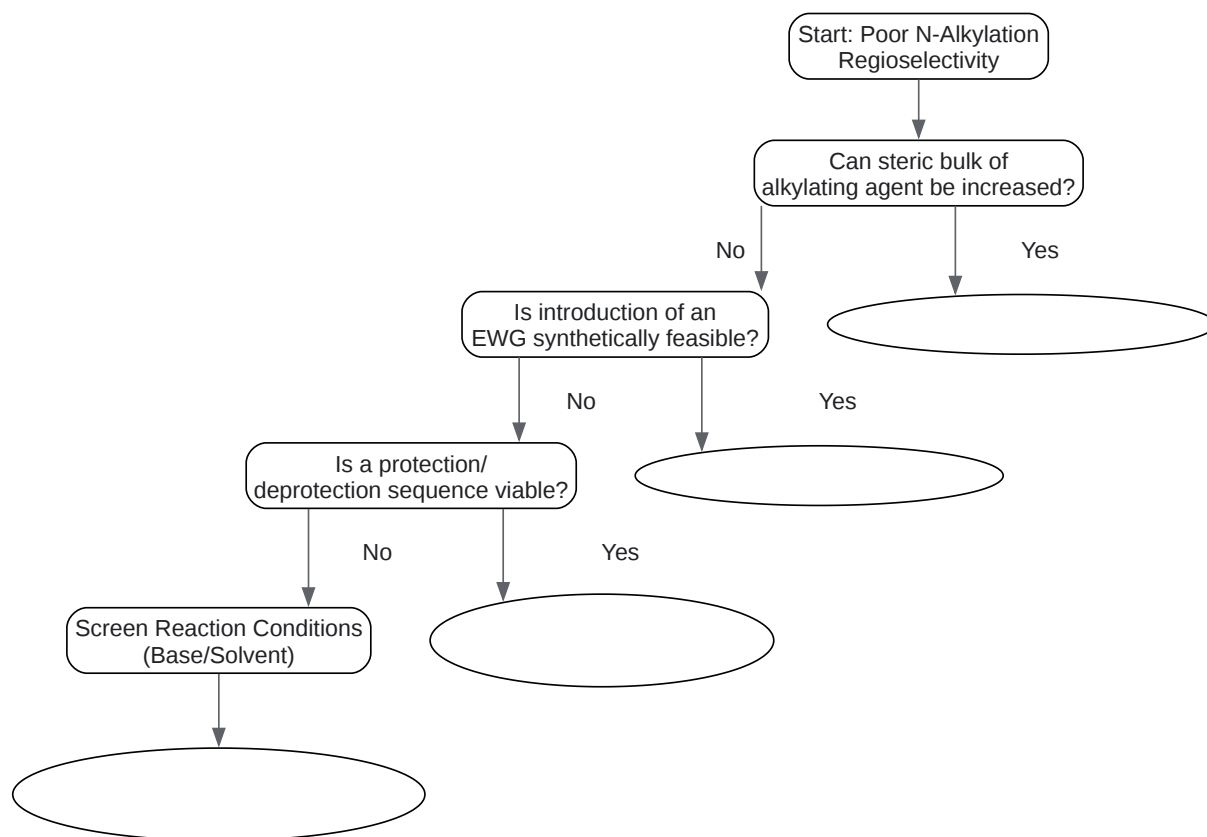

[Click to download full resolution via product page](#)

Caption: Decision workflow for troubleshooting poor N-alkylation regioselectivity.

Scenario 2: Lack of Selectivity in C-H Arylation

Problem: "I'm attempting a direct C-H arylation on my N-substituted imidazole, but I'm getting a mixture of C2, C4, and C5-arylated products."

Root Cause Analysis: The relative reactivity of the C-H bonds in an imidazole ring is C5 > C2 > C4 for electrophilic substitution.[1] However, under transition-metal-catalyzed conditions, this order can be altered by the mechanism of C-H activation, the directing ability of substituents, and the specific catalyst/ligand/base system employed.[1][14]

Solutions & Troubleshooting Steps:

- Catalyst and Ligand Selection:
 - Rationale: The choice of metal catalyst and its coordinating ligand is critical. Palladium catalysts are widely used, and the ligand can sterically and electronically tune the metal center to favor a specific site.[1][7] Nickel catalysts have also emerged as a powerful alternative for C2 arylation.[14][15]
 - Actionable Advice: For C5-arylation of N-SEM imidazoles, a common system is Pd(OAc)₂ with a phosphine ligand like SPhos.[7] For selective C2-arylation, switching to a nickel-based catalyst system, such as Ni(OTf)₂ with a dcype ligand, has proven effective.[14]
- The "SEM-Switch" for C4 Functionalization:
 - Rationale: The C4 position is the least reactive towards direct C-H functionalization.[1] A clever strategy known as the "SEM-switch" involves the transposition of the SEM protecting group from N1 to N3. This migration activates the C4 position for subsequent arylation.[1][2]
 - Actionable Advice: If C4 functionalization is the goal, first protect the imidazole with an SEM group. Perform C5 and/or C2 arylations as desired. Then, induce the SEM-switch to move the protecting group to N3, which will then allow for the arylation of the C4 position. [7]
- Control by Base and Solvent:
 - Rationale: The base is not just a stoichiometric reagent; it can be involved in the C-H activation step (concerted metalation-deprotonation). The choice of base can therefore dictate the site of metalation.[1]

- Actionable Advice: As demonstrated by Daugulis and others, for the Pd-catalyzed arylation of 1-SEM-imidazole, using K_2CO_3 in dioxane favors C5 arylation.[7] Switching to a stronger, bulkier base like NaOt-Bu in a nonpolar solvent like toluene can promote selective C2 arylation.[1]

Table 1: Effect of Reaction Conditions on C-H Arylation Regioselectivity of 1-SEM-Imidazole

Target Position	Catalyst System	Base	Solvent	Typical Outcome	Reference
C5	Pd(OAc) ₂ / SPhos	K ₂ CO ₃	1,4-Dioxane	Selective C5-arylation	[7]
C2	Pd(OAc) ₂ / SPhos	NaOt-Bu	Toluene	Selective C2-arylation	[1]
C2	Ni(OTf) ₂ / dcype	K ₃ PO ₄	t-amylOH	Selective C2-arylation	[14]

III. Frequently Asked Questions (FAQs)

Q2: How can I distinguish between the different N1 and N3 alkylated regioisomers?

A2: Unambiguous characterization is crucial. Several analytical techniques can be employed:

- Nuclear Magnetic Resonance (NMR) Spectroscopy: This is the most powerful tool. ¹H and ¹³C NMR will show different chemical shifts for the ring protons and carbons in the two isomers. More definitively, 2D NMR techniques like NOESY (for through-space correlations) and HMBC (for through-bond correlations) can establish the connectivity between the alkyl group and the specific nitrogen atom. For example, a NOESY correlation between the protons of the N-alkyl group and the C2-H or C5-H proton can confirm the substitution pattern.[16]

Q3: Are there directing groups other than SEM that are effective for controlling regioselectivity?

A3: Yes, while the SEM group is highly versatile, other groups can be used. The choice often depends on the desired downstream chemistry and the required deprotection conditions.

- Trityl (Tr): As mentioned, this bulky group is excellent for directing N-alkylation due to steric hindrance and is easily removed with mild acid.[13]
- Boc (tert-Butoxycarbonyl): The Boc group is another common N-protecting group. While useful, its removal often requires acidic conditions which might not be compatible with other functional groups in the molecule. However, selective deprotection of N-Boc imidazoles in the presence of N-Boc amines can be achieved using NaBH₄ in ethanol.[17]

Q4: Can I functionalize all three C-H positions of the imidazole ring sequentially?

A4: Yes, a programmable approach has been developed that allows for the sequential and regioselective arylation of all three C-H bonds (C5, C2, and C4).[1][2] This strategy relies on the judicious use of different catalytic systems and the "SEM-switch" to access the otherwise unreactive C4 position.[1][7]

Workflow for Sequential Tri-Arylation of Imidazole:

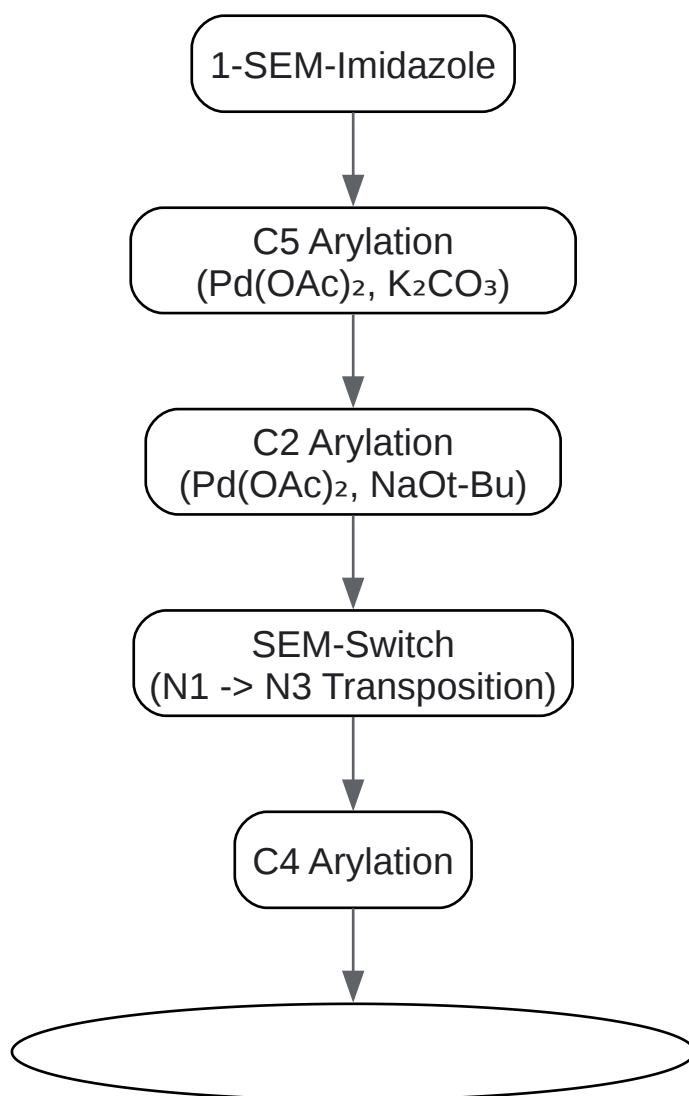

[Click to download full resolution via product page](#)

Need Custom Synthesis?

BenchChem offers custom synthesis for rare earth carbides and specific isotopic labeling.

Email: info@benchchem.com or [Request Quote Online](#).

Sources

- 1. C–H Bonds as Ubiquitous Functionality: A General Approach to Complex Arylated Imidazoles via Regioselective Sequential Arylation of All Three C–H Bonds and Regioselective N-Alkylation Enabled by SEM-Group Transposition - PMC [[pmc.ncbi.nlm.nih.gov](https://pubmed.ncbi.nlm.nih.gov)]

- [2. pubs.acs.org \[pubs.acs.org\]](https://pubs.acs.org)
- [3. Imidazole: Synthesis, Functionalization and Physicochemical Properties of a Privileged Structure in Medicinal Chemistry - PMC \[pmc.ncbi.nlm.nih.gov\]](https://pubmed.ncbi.nlm.nih.gov/)
- [4. researchgate.net \[researchgate.net\]](https://www.researchgate.net)
- [5. Imidazole: Synthesis, Functionalization and Physicochemical Properties of a Privileged Structure in Medicinal Chemistry \[ouci.dntb.gov.ua\]](https://pubmed.ncbi.nlm.nih.gov/)
- [6. \[PDF\] Imidazole: Synthesis, Functionalization and Physicochemical Properties of a Privileged Structure in Medicinal Chemistry | Semantic Scholar \[semanticscholar.org\]](https://www.semanticscholar.org)
- [7. benchchem.com \[benchchem.com\]](https://www.benchchem.com)
- [8. benchchem.com \[benchchem.com\]](https://www.benchchem.com)
- [9. benchchem.com \[benchchem.com\]](https://www.benchchem.com)
- [10. Exclusive Solvent-Controlled Regioselective Catalytic Synthesis of Potentially Bioactive Imidazolidineiminodithiones: NMR Analysis, Computational Studies and X-ray Crystal Structures - PMC \[pmc.ncbi.nlm.nih.gov\]](https://pubmed.ncbi.nlm.nih.gov/)
- [11. researchgate.net \[researchgate.net\]](https://www.researchgate.net)
- [12. jocpr.com \[jocpr.com\]](https://www.jocpr.com)
- [13. benchchem.com \[benchchem.com\]](https://www.benchchem.com)
- [14. C–H arylation and alkenylation of imidazoles by nickel catalysis: solvent-accelerated imidazole C–H activation - Chemical Science \(RSC Publishing\) DOI:10.1039/C5SC02942B \[pubs.rsc.org\]](https://pubs.rsc.org)
- [15. researchgate.net \[researchgate.net\]](https://www.researchgate.net)
- [16. benchchem.com \[benchchem.com\]](https://www.benchchem.com)
- [17. arkat-usa.org \[arkat-usa.org\]](https://www.arkat-usa.org)
- To cite this document: BenchChem. [Technical Support Center: Improving Regioselectivity in Imidazole Functionalization]. BenchChem, [2026]. [Online PDF]. Available at: [\[https://www.benchchem.com/product/b102120/docs#technical-support-center-improving-regioselectivity-in-imidazole-functionalization\]](https://www.benchchem.com/product/b102120/docs#technical-support-center-improving-regioselectivity-in-imidazole-functionalization)

Disclaimer & Data Validity:

The information provided in this document is for Research Use Only (RUO) and is strictly not intended for diagnostic or therapeutic procedures. While BenchChem strives to provide

accurate protocols, we make no warranties, express or implied, regarding the fitness of this product for every specific experimental setup.

Technical Support: The protocols provided are for reference purposes. Unsure if this reagent suits your experiment?

Need Industrial/Bulk Grade? [Request Custom Synthesis Quote](#)

BenchChem

Our mission is to be the trusted global source of essential and advanced chemicals, empowering scientists and researchers to drive progress in science and industry.

Contact

Address: 3281 E Guasti Rd

Ontario, CA 91761, United States

Phone: (601) 213-4426

Email: info@benchchem.com

[Contact our Ph.D. Support Team for a compatibility check](#)