

Technical Monograph: DMFL-TPD – Molecular Architecture and Synthetic Protocols for Optoelectronic Applications

Author: BenchChem Technical Support Team. **Date:** May 2026

Compound of Interest

Compound Name: *Dmfl-tpd*
CAS No.: 677350-83-3
Cat. No.: B1601899

[Get Quote](#)

Executive Summary

DMFL-TPD (N,N'-Bis(3-methylphenyl)-N,N'-diphenyl-9,9-dimethylfluorene-2,7-diamine) represents a critical evolution in the design of Hole Transport Materials (HTMs) for organic light-emitting diodes (OLEDs). By replacing the biphenyl core of the traditional TPD molecule with a rigid, planar 9,9-dimethylfluorene moiety, **DMFL-TPD** achieves superior thermal stability and higher glass transition temperatures (

) while maintaining excellent hole mobility.

This guide provides a definitive technical analysis of **DMFL-TPD**, detailing its retrosynthetic logic, industrial-grade synthesis via Buchwald-Hartwig amination, and its functional integration into high-efficiency electroluminescent devices.

Molecular Architecture and Design Logic

The structural efficacy of **DMFL-TPD** (Formula:

; MW: 556.74 g/mol) is derived from three distinct pharmacophores tailored for optoelectronics:

- **9,9-Dimethylfluorene Core:** Unlike the rotationally free biphenyl bridge in standard TPD, the fluorene core is fused and planar. This rigidity suppresses non-radiative decay pathways and increases the glass transition temperature, preventing morphological degradation (crystallization) of thin films during device operation.
- **C9-Dimethyl Substitution:** The gem-dimethyl groups at the 9-position of the fluorene ring provide steric bulk perpendicular to the -conjugated plane. This prevents -
-
stacking aggregation, which can lead to exciton quenching, while simultaneously improving solubility in organic solvents (THF, Toluene) for solution processing.
- **Diphenylamine Wings (m-Tolyl groups):** The nitrogen atoms at the 2,7-positions are capped with phenyl and m-tolyl rings. The meta-methyl substitution breaks molecular symmetry slightly, further inhibiting crystallization and tuning the HOMO energy level to align with common anode materials like ITO (Indium Tin Oxide).

Physicochemical Profile[1][2][3][4][5][6][7]

Property	Value	Significance
HOMO Level	~ -5.3 to -5.4 eV	Facilitates ohmic hole injection from ITO/HIL.
LUMO Level	~ -2.3 to -2.4 eV	High electron barrier prevents electron leakage into the anode.
Triplet Energy ()	High (> 2.3 eV)	Suitable host for red/green phosphorescent emitters; prevents triplet back-transfer.
Thermal Stability ()	> 290°C (0.5% loss)	Survives vacuum thermal evaporation processes.
Absorption Peak	376 nm (in THF)	Transparent in the visible region (400-700 nm).

Synthesis Pathway: Buchwald-Hartwig Amination

The synthesis of **DMFL-TPD** is a precision operation requiring inert atmosphere techniques. The most robust pathway utilizes a Palladium-catalyzed C-N cross-coupling (Buchwald-Hartwig amination) between a dihalo-fluorene precursor and a secondary amine.

Retrosynthetic Analysis

- Target: **DMFL-TPD**
- Disconnection: Aryl C-N bond at the 2,7-fluorene positions.
- Synthon A (Electrophile): 2,7-Dibromo-9,9-dimethylfluorene.
- Synthon B (Nucleophile): N-(3-methylphenyl)aniline (3-Methyldiphenylamine).

Experimental Protocol

Reagents:

- Precursor A: 2,7-Dibromo-9,9-dimethylfluorene (1.0 eq)
- Precursor B: 3-Methyldiphenylamine (2.2 eq)
- Catalyst: Tris(dibenzylideneacetone)dipalladium(0) [] (1-2 mol%)
- Ligand: Tri-tert-butylphosphine [] or DPPF (2-4 mol%)
- Base: Sodium tert-butoxide () (3.0 eq)
- Solvent: Anhydrous Toluene or Xylene.

Step-by-Step Methodology:

- Inert Setup: Flame-dry a three-neck round-bottom flask equipped with a reflux condenser and magnetic stir bar. Cycle with Argon/Vacuum (3x) to remove oxygen, which poisons the Pd(0) catalyst.
- Charging: Under positive Argon flow, add 2,7-Dibromo-9,9-dimethylfluorene (10 mmol), 3-Methyldiphenylamine (22 mmol), and (30 mmol).
- Catalyst Addition: Add the and phosphine ligand. Note: Pre-mixing the catalyst and ligand in a small volume of solvent to form the active catalytic species is often preferred.
- Reaction: Inject anhydrous toluene (via syringe) to achieve a concentration of ~0.1 M. Heat the mixture to reflux (110°C) for 12–24 hours. Monitor reaction progress via TLC (Silica gel; Hexane:DCM 4:1) until the dibromo starting material is fully consumed.

- Workup: Cool to room temperature. Filter the mixture through a pad of Celite to remove inorganic salts and Palladium black. Wash the pad with DCM.
- Purification (Chemical): Concentrate the filtrate under reduced pressure. Recrystallize the crude solid from a Toluene/Ethanol mixture to yield a white/off-white powder.
- Purification (Device Grade): Perform Vacuum Sublimation at Torr. This step is non-negotiable for OLED applications to remove trace ionic impurities and solvent residues that act as charge traps.

Reaction Mechanism Visualization

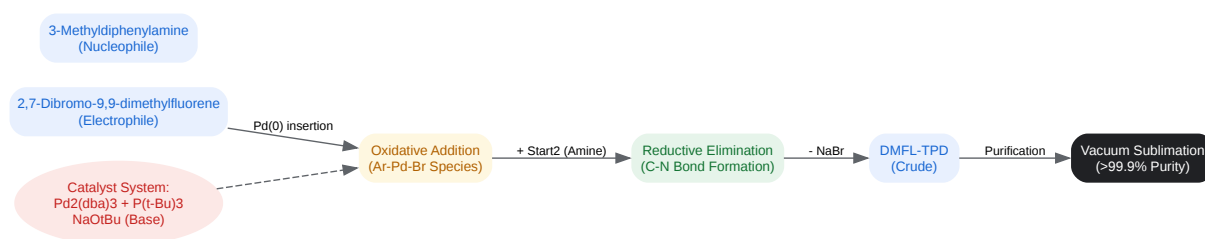

[Click to download full resolution via product page](#)

Figure 1: Palladium-catalyzed cross-coupling pathway for **DMFL-TPD** synthesis.

Device Integration and Performance

In a standard OLED stack, **DMFL-TPD** serves primarily as the Hole Transport Layer (HTL). Its high triplet energy also makes it an effective Electron Blocking Layer (EBL), preventing electrons from overshooting the emission zone.

Standard Device Architecture

A typical high-efficiency phosphorescent OLED (PhOLED) utilizing **DMFL-TPD** would follow this stack:

- Anode: ITO (Indium Tin Oxide)
- HIL: PEDOT:PSS or HAT-CN (Hole Injection)
- HTL: **DMFL-TPD** (Transports holes, blocks electrons)[1]
- EML: Host matrix doped with Ir(ppy)₃ (Green) or Ir(piq)₂acac (Red)
- ETL: TPBi or Alq₃ (Electron Transport)
- Cathode: LiF / Al

Functional Mechanism

When a voltage is applied, holes are injected from the ITO into the HOMO of **DMFL-TPD**. The hole mobility (

) of fluorene-based amines is typically in the range of

to

, which is sufficient to balance charge transport when paired with standard electron transport materials.

Crucially, the LUMO of **DMFL-TPD** is sufficiently high (closer to vacuum) to present a large energy barrier to electrons arriving from the EML, confining excitons within the emissive layer for maximum radiative recombination efficiency.

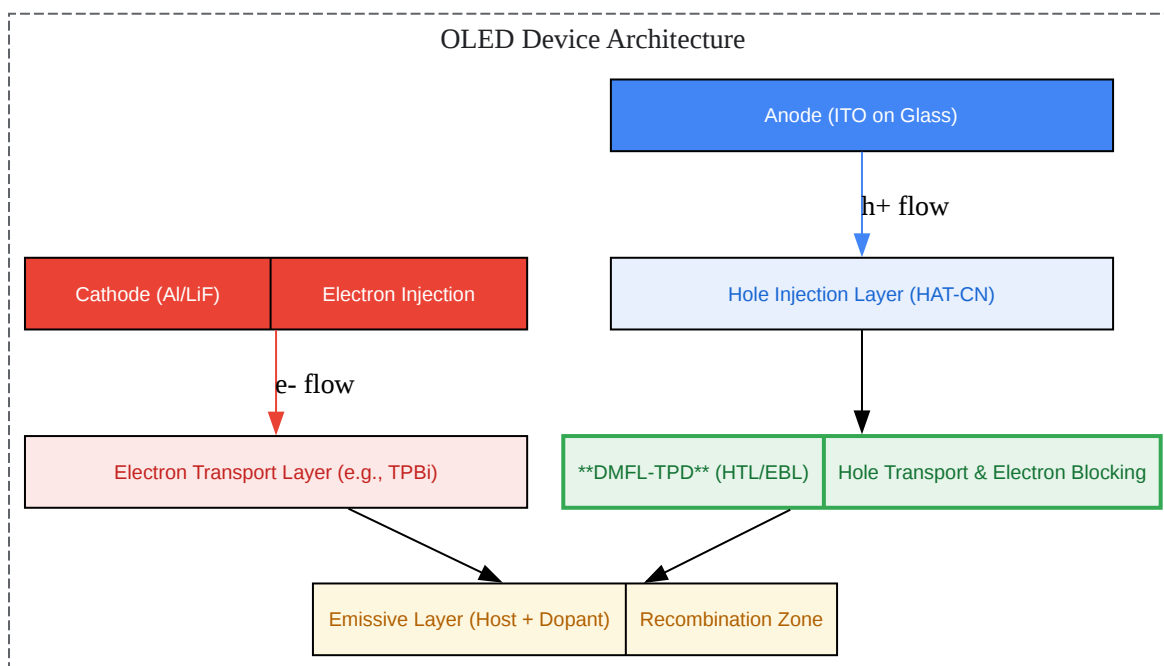

[Click to download full resolution via product page](#)

Figure 2: Stratified structure of an OLED highlighting the functional position of **DMFL-TPD**.

References

- Lumtec Corp. (2025). **DMFL-TPD** Product Specification and Spectral Data. Luminescence Technology Corporation.[1] [Link](#)
- Warshel Chemical Ltd. (2025).[2] Material Safety Data Sheet: **DMFL-TPD** (CAS 677350-83-3).[1] Warshel Chemical.[2] [Link](#)
- Kabe, R., et al. (2026).[3] "Review of Organic Persistent Phosphors: Classifications by Material Forms, Applications, and Mechanisms". ResearchGate. [Link](#)
- TCI Chemicals. (2024). Organic Electronics Materials Brochure: Hole Transport Materials. Tokyo Chemical Industry. [Link](#)

- European Patent Office. (2012). EP2401254B1 - Quinone compounds as dopants in organic electronics. Google Patents. [Link](#)

Need Custom Synthesis?

BenchChem offers custom synthesis for rare earth carbides and specific isotopic labeling.

Email: info@benchchem.com or [Request Quote Online](#).

Sources

- 1. lumtec.com.tw [lumtec.com.tw]
- 2. warshel.com [warshel.com]
- 3. researchgate.net [researchgate.net]
- To cite this document: BenchChem. [Technical Monograph: DMFL-TPD – Molecular Architecture and Synthetic Protocols for Optoelectronic Applications]. BenchChem, [2026]. [Online PDF]. Available at: [<https://www.benchchem.com/product/b1601899/docs#technical-monograph-dmfl-tpd-molecular-architecture-and-synthetic-protocols-for-optoelectronic-applications>]

Disclaimer & Data Validity:

The information provided in this document is for Research Use Only (RUO) and is strictly not intended for diagnostic or therapeutic procedures. While BenchChem strives to provide accurate protocols, we make no warranties, express or implied, regarding the fitness of this product for every specific experimental setup.

Technical Support: The protocols provided are for reference purposes. Unsure if this reagent suits your experiment?

Need Industrial/Bulk Grade? [Request Custom Synthesis Quote](#)

BenchChem

Our mission is to be the trusted global source of essential and advanced chemicals, empowering scientists and researchers to drive progress in science and industry.

Contact

Address: 3281 E Guasti Rd

Ontario, CA 91761, United States

Phone: (601) 213-4426

Email: info@benchchem.com

[Contact our Ph.D. Support Team for a compatibility check](#)