

Minimizing decomposition of furopyrrole esters during column chromatography

Author: BenchChem Technical Support Team. **Date:** April 2026

Compound of Interest

Compound Name: ethyl 2-methyl-4H-furo[3,2-b]pyrrole-5-carboxylate

CAS No.: 80709-78-0

Cat. No.: B1601115

[Get Quote](#)

Chromatography Technical Support: Furopyrrole Ester Purification

Status: Active Ticket ID: FP-EST-001 Subject: Minimizing decomposition of furopyrrole esters during column chromatography Assigned Specialist: Senior Application Scientist

Executive Summary: The "Black Tar" Phenomenon

You are likely reading this because your crude furopyrrole ester showed a clean NMR profile, but after silica gel chromatography, you recovered a fraction of the mass, often as a dark, insoluble oligomer or a hydrolyzed carboxylic acid.

The Root Cause: Furopyrrole esters reside at a precarious chemical intersection. The electron-rich pyrrole/furan core is susceptible to acid-catalyzed polymerization (initiated by protonation at the

-carbon), while the ester moiety is prone to surface-mediated hydrolysis. Standard silica gel is acidic (

) due to surface silanol groups (

), acting as a heterogeneous acid catalyst that destroys your compound.

This guide provides the standard operating procedures (SOPs) to neutralize this acidity and recover your material.

Diagnostic FAQs

Q: My compound streaks on the TLC plate and turns the silica spot yellow/brown. What does this mean? A: This is the hallmark of acid-sensitivity. The streaking indicates continuous decomposition as the compound travels up the plate. The color change is oxidative degradation or polymerization occurring in real-time on the active surface.

- Action: Do not run a standard column. Proceed immediately to the Buffered Silica Protocol (Section 3).

Q: I recovered the product, but the ester is gone (mass -14/28 or + water). A: You experienced on-column hydrolysis. The water adsorbed on the silica surface, catalyzed by the acidic silanols, hydrolyzed your ester to the carboxylic acid.

- Action: Use Anhydrous/Neutralized conditions or switch to Neutral Alumina (Section 4).

Q: Can I just add Triethylamine (TEA) to my eluent? A: Adding TEA to the eluent helps, but it is often insufficient for highly sensitive compounds. As the solvent front moves, the TEA may be stripped away from the silica sites before your compound arrives, or the "heat of adsorption" may trigger decomposition upon loading.

- Action: You must pre-buffer the column (slurry pack with base) to ensure the entire stationary phase is deactivated before the sample touches it.

Core Protocol: The Buffered Silica Method

This is the gold-standard method for purifying acid-sensitive heterocycles on silica gel.

Reagents Required

- Silica Gel 60 (Standard mesh)
- Triethylamine (TEA) or Pyridine (1-3% v/v)
- Elution Solvents (Hexane/EtOAc or DCM/MeOH)

Step-by-Step Procedure

- The Slurry Pack (Critical):
 - Prepare your starting eluent mixture (e.g., 90:10 Hexane:EtOAc).
 - Add 1% to 3% Triethylamine (TEA) to this solvent mixture.
 - Slurry your silica gel in this TEA-spiked solvent. Do not dry pack.
 - Pour the slurry into the column.
- The Pre-Flush:
 - Flush the packed column with at least 2 column volumes (CV) of the TEA-containing solvent.
 - Why? This ensures every acidic silanol site throughout the column length is capped (neutralized) by the amine.
- Sample Loading:
 - Dissolve your crude material in a minimum amount of the TEA-spiked eluent (or DCM with 1% TEA).
 - Avoid: Do not load using pure DCM or chloroform without TEA, as these solvents can become slightly acidic over time.
- Elution:
 - Run the column using your gradient.

- Note: You can maintain 0.5% TEA in the eluent throughout the run to prevent equilibrium shift, though the pre-flush is usually the most important step.
- Post-Run Workup:
 - TEA has a high boiling point () and can be difficult to remove on a rotovap.
 - Removal: Azeotrope with heptane, or if your compound is stable to mild base, wash the combined fractions with saturated (only if the compound is not water-soluble) before evaporation.

Decision Matrix & Workflow

Use this logic flow to determine the correct purification strategy for your specific furopyrrrole derivative.

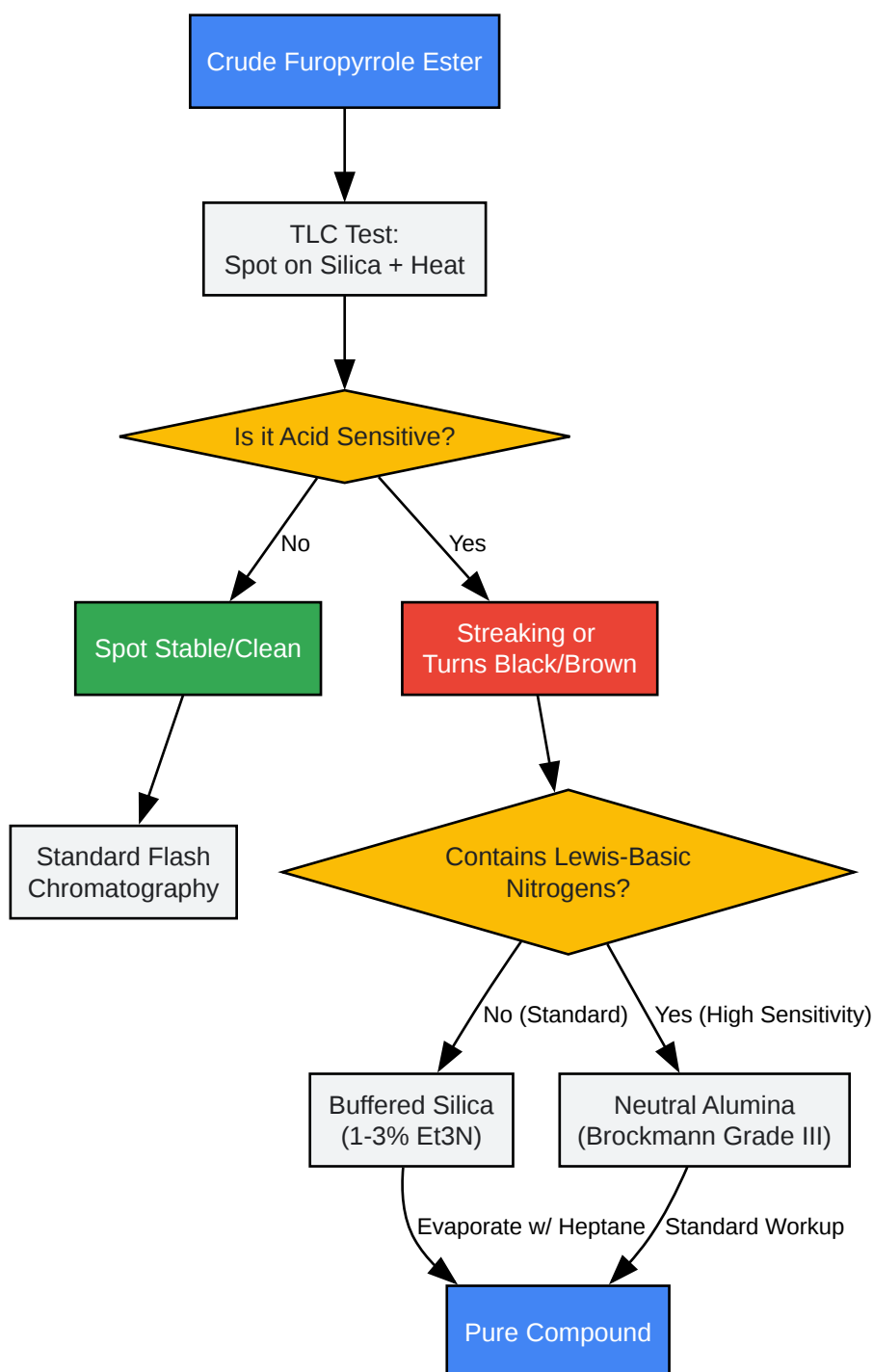

[Click to download full resolution via product page](#)

Figure 1: Decision tree for selecting the appropriate stationary phase based on compound stability.

Alternative Stationary Phases

If the Buffered Silica method fails (e.g., compound still degrades or TEA reacts with the ester), switch stationary phases immediately.

Stationary Phase	Acidity ()	Suitability for Fuopyrroles	Notes
Silica Gel (Untreated)	4.0 – 5.0	Low	Causes hydrolysis and polymerization.
Silica + 1% TEA	7.0 – 8.0	High	Best balance of cost and resolution.
Neutral Alumina	7.0 – 7.5	Very High	Use for extremely acid-sensitive esters. Lower resolution than silica.
Florisil	8.5	Medium	Magnesium silicate. Good for very polar amines, but can be too basic for labile esters.
C18 (Reverse Phase)	Neutral	Medium	Excellent stability, but fuopyrroles often have poor solubility in aqueous mobile phases.

Technical Note on Alumina: Alumina comes in different "Activities" (water content). For sensitive fuopyrroles, use Neutral Alumina, Brockmann Grade III.

- To convert Grade I (commercial) to Grade III: Add 6% water (w/w) to the alumina and shake until free-flowing. This lowers the Lewis acidity and prevents irreversible binding.

Mechanism of Stabilization

Understanding the chemical interaction helps in troubleshooting.

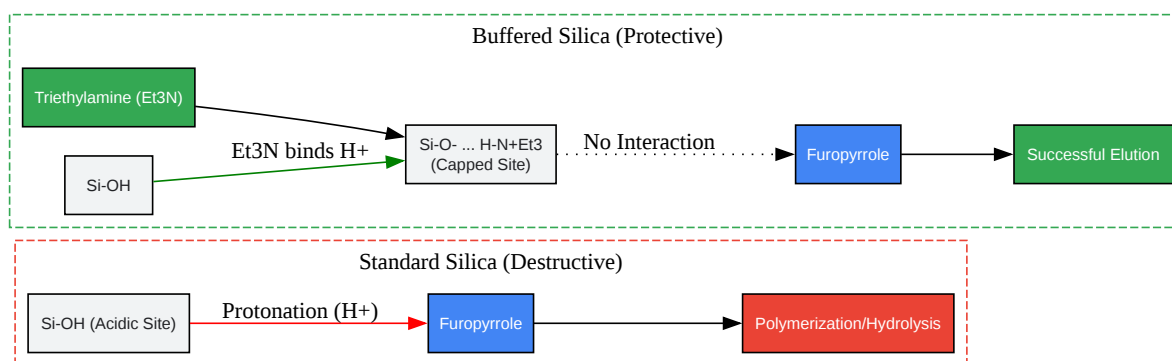

[Click to download full resolution via product page](#)

Figure 2: Mechanism showing how Triethylamine blocks acidic silanol sites, preventing protonation of the fuopyrrole.

References

- Armarego, W. L. F., & Chai, C. L. L. (2013). Purification of Laboratory Chemicals (7th ed.). Butterworth-Heinemann. (Standard reference for deactivation of silica gel and alumina grades).
- Organic Syntheses. (2010). General procedures for handling acid-sensitive furan derivatives. Org. Synth. Coll. Vol. 11, p. 35. (Describes the use of TEA-treated silica for furan derivatives).
- Reich, H. J. (2024). Common Chromatographic Adsorbents and Solvents. data of silica vs. alumina).
- Teledyne ISCO. (2023). Purification of Delicate Compounds with RediSep Gold Diol and Cyano Columns. Application Note AN87. (Discusses alternative bonded phases for acid-sensitive compounds). [[Link to Teledyne ISCO](#)]([Link](#))

- To cite this document: BenchChem. [Minimizing decomposition of fuopyrrole esters during column chromatography]. BenchChem, [2026]. [Online PDF]. Available at: [<https://www.benchchem.com/product/b1601115/docs#minimizing-decomposition-of-fuopyrrole-esters-during-column-chromatography>]

Disclaimer & Data Validity:

The information provided in this document is for Research Use Only (RUO) and is strictly not intended for diagnostic or therapeutic procedures. While BenchChem strives to provide accurate protocols, we make no warranties, express or implied, regarding the fitness of this product for every specific experimental setup.

Technical Support: The protocols provided are for reference purposes. Unsure if this reagent suits your experiment?

Need Industrial/Bulk Grade? [Request Custom Synthesis Quote](#)

BenchChem

Our mission is to be the trusted global source of essential and advanced chemicals, empowering scientists and researchers to drive progress in science and industry.

Contact

Address: 3281 E Guasti Rd
Ontario, CA 91761, United States
Phone: (601) 213-4426
Email: info@benchchem.com

[Contact our Ph.D. Support Team for a compatibility check](#)