

Comparative Technical Guide: Dmfl-TPD vs. TPD Hole Mobility

Author: BenchChem Technical Support Team. **Date:** May 2026

Compound of Interest

Compound Name:	Dmfl-tpd
CAS No.:	677350-83-3
Cat. No.:	B1601899

Get Quote

Executive Summary

This guide provides a rigorous technical comparison between TPD (N,N'-Bis(3-methylphenyl)-N,N'-diphenylbenzidine) and its fluorene-modified derivative, **Dmfl-TPD** (N,N'-Bis(3-methylphenyl)-N,N'-diphenyl-9,9-dimethylfluoren-2,7-diamine).

While TPD has served as the "fruit fly" of Hole Transport Layers (HTL) for decades, its application is severely limited by low thermal stability (

) and morphological degradation.[1] **Dmfl-TPD** integrates a rigid 9,9-dimethylfluorene core, which suppresses crystallization and enhances the glass transition temperature (

) while maintaining—and often exceeding—the hole mobility (

) of standard TPD due to reduced geometric reorganization energy.

This document details the structural causality of these properties, provides comparative data, and outlines a self-validating Space-Charge Limited Current (SCLC) protocol for quantifying mobility in your own lab.

Structural Causality: The "Fluorene Effect"

To understand the mobility difference, one must analyze the molecular geometry and packing efficiency.^[1]

Standard TPD (The Baseline)

- Core: Biphenyl.^[1]
- Geometry: The two phenyl rings in the biphenyl core are twisted relative to each other (dihedral angle) to minimize steric hindrance between ortho-hydrogens.
- Consequence: This non-planar "twist" increases the internal reorganization energy () during hole hopping.^[1] Furthermore, the flexible core leads to a low Glass Transition Temperature (), causing the film to crystallize over time, destroying the device interface.

Dmfl-TPD (The Evolution)

- Core: 9,9-Dimethylfluorene.^{[1][2][3][4][5][6]}
- Geometry: The fluorene core forces the two phenyl rings into a co-planar, fused rigid structure.^[1]
- Consequence:
 - Lower Reorganization Energy: The rigid core undergoes less geometric distortion upon oxidation (hole capture), facilitating faster charge transfer rates () according to Marcus Theory.^[1]
 - Enhanced Stability: The bulky 9,9-dimethyl groups prevent overly tight -stacking (which causes crystallization) while the rigid backbone raises significantly (

), ensuring amorphous film stability.[1]

Charge Transport Pathway Visualization

The following diagram illustrates the impact of the core structure on charge hopping probability.

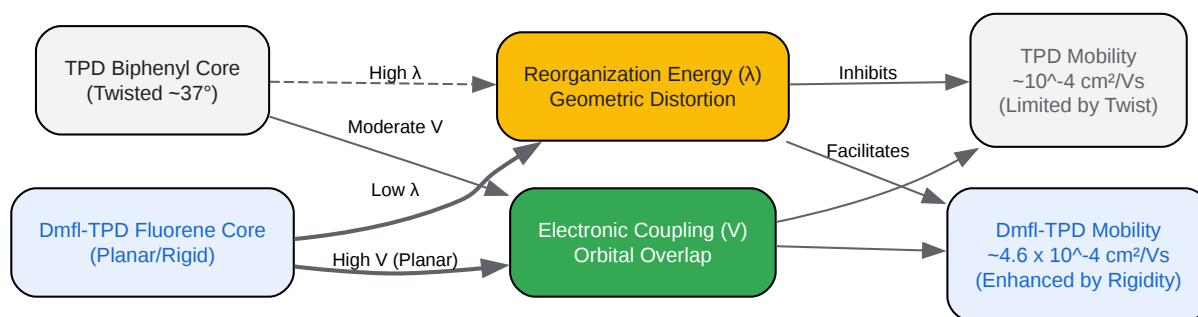

[Click to download full resolution via product page](#)

Figure 1: Mechanistic pathway showing how the rigid fluorene core of **Dmfl-TPD** reduces reorganization energy, leading to superior hole mobility compared to the twisted biphenyl core of TPD.

Comparative Data Profile

The following data aggregates standard values from literature and commercial specifications. Note that mobility values are highly dependent on electric field strength (

) and measurement method (TOF vs. SCLC).

Property	Standard TPD	Dmfl-TPD	Advantage
CAS Number	65181-78-4	677350-83-3	—
Core Structure	Biphenyl (Twisted)	9,9-Dimethylfluorene (Planar)	Dmfl (Rigidity)
Hole Mobility ()	cm /Vs	cm /Vs	2x - 5x Higher
Glass Transition ()		(Typ.[1])	Thermal Stability
HOMO Level	to eV	to eV	Better Injection
Solubility	Moderate (Chlorobenzene)	High (Toluene/Chlorobenzene)	Processability
Morphology	Prone to Crystallization	Stable Amorphous Film	Device Lifetime

Data Sources: Synthesized from Adachi et al. [1], MDPI Fluorene Studies [2], and Lumtec Specifications [3].

Experimental Protocol: Self-Validating SCLC Measurement

To verify the mobility of **Dmfl-TPD** in your specific device architecture, do not rely solely on literature values. Use the Space-Charge Limited Current (SCLC) method.[1][3] This method is "self-validating" because the data must fit the Mott-Gurney law perfectly to be considered valid; if it doesn't fit, the experiment has failed (e.g., due to leakage or traps), preventing false positives.

Device Architecture (Hole-Only Device)

Fabricate a "Hole-Only" device to isolate hole transport.

- Anode: ITO (Indium Tin Oxide) / PEDOT:PSS (40 nm)
- Active Layer: **Dmfi-TPD** (100 nm - 150 nm)
- Cathode:

(10 nm) / Ag (100 nm)

- Note: Using

/Ag as the cathode prevents electron injection, ensuring only holes flow.^[1]

Measurement Workflow

- Fabrication: Spin-coat **Dmfi-TPD** from Chlorobenzene (20 mg/mL) at 2000 rpm. Anneal at for 10 min.^[1]
- Thickness Check: Measure film thickness () exactly using a profilometer (Dektak) or Ellipsometry.^[1] Accuracy here is critical as mobility scales with .
- IV Sweep: Perform a J-V sweep from 0V to 10V using a source meter (e.g., Keithley 2400).
- Log-Log Plot: Plot Current Density () vs. Voltage () on a log-log scale.

Data Analysis (The Mott-Gurney Fit)

Look for the "SCLC Region" where the slope of the log-log plot is exactly 2.

- : Current density (A/m^2)[7][8]
- : Permittivity of free space
- : Relative permittivity (assume 3.0 for organic semiconductors)
- : Hole mobility (the unknown)[9]
- : Film thickness (m)

Validation Rule: If the slope is 1 (Ohmic) or >3 (Trap-Limited), the SCLC model is invalid. Only calculate mobility from the region where slope

[1]

SCLC Logic Diagram

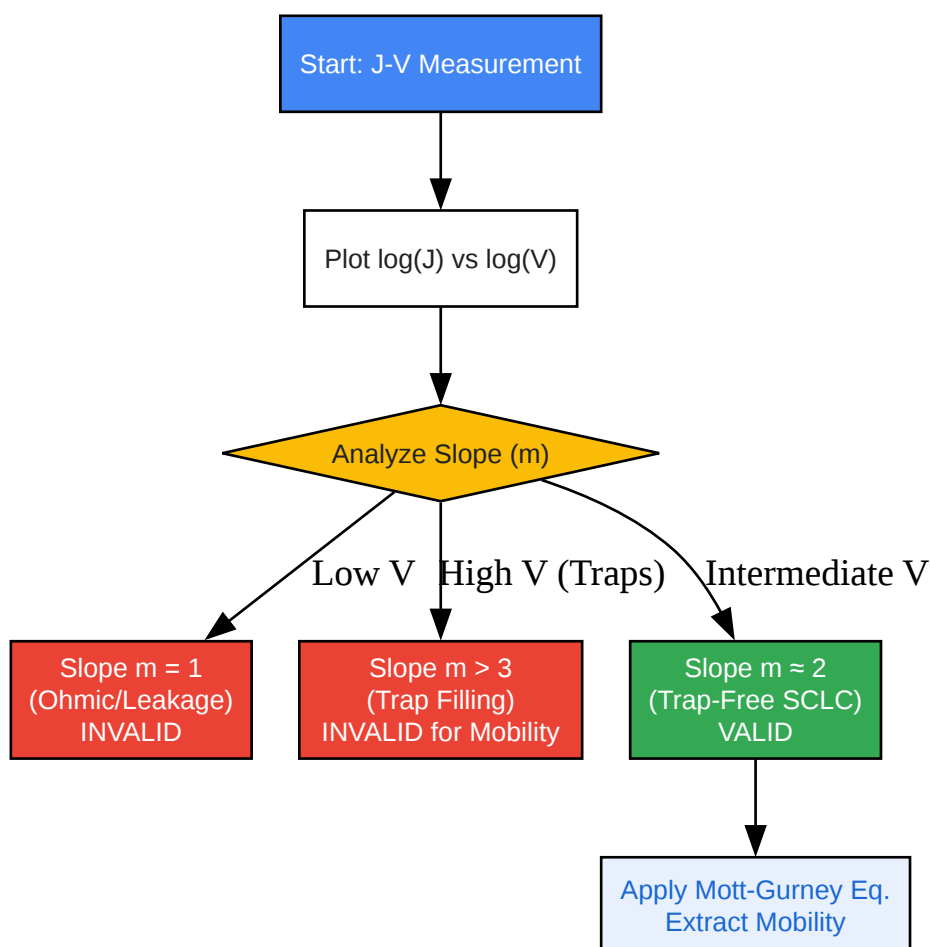

[Click to download full resolution via product page](#)

Figure 2: Decision tree for validating SCLC data.[1] Mobility extraction is only scientifically valid in the "Slope ≈ 2 " regime.

Synthesis & Handling Notes

- Solubility: **Dmfl-TPD** is highly soluble in common non-polar solvents (Chloroform, Toluene, Chlorobenzene).[1]
- Purification: For mobility measurements, sublimation-grade material (>99.5%) is required.[1] Impurities act as charge traps, artificially lowering the measured mobility.[1]
- Storage: Store in a nitrogen-filled glovebox. While **Dmfl-TPD** is more stable than TPD, the amine groups are still susceptible to photo-oxidation over long periods.[1]

References

- Adachi, C. et al. "Organic electroluminescent device having a hole conductor as an emitting layer." [1] Applied Physics Letters, 55, 1489 (1989). [1] [Link](#)
- Zhang, Y. et al. "Hole-Transporting Materials Based on a Fluorene Unit for Efficient Optoelectronic Devices." [1] Materials, 17, 5417 (2024). [1] [Link](#)
- Lumtec Corp. "Product Specification: **DMFL-TPD** (LT-E109)." Lumtec Catalog. [Link](#)
- Stolka, M. et al. "Electronic transport in disordered organic polymers." [1] Journal of Chemical Physics, 86, 3044 (1987). [1] (Foundational text on TPD mobility). [Link](#)

Need Custom Synthesis?

BenchChem offers custom synthesis for rare earth carbides and specific isotopic labeling.

Email: info@benchchem.com or [Request Quote Online](#).

Sources

- 1. 9,9-Dimethylfluorene | C₁₅H₁₄ | CID 78325 - PubChem [pubchem.ncbi.nlm.nih.gov]
- 2. 9,9-Dimethyl-N,N'-bis(3-methylphenyl)-N,N'-diphenyl-9H-fluorene-2,7-diamine | 677350-83-3 [chemicalbook.com]

- [3. researchgate.net \[researchgate.net\]](#)
- [4. Hole-Transporting Materials Based on a Fluorene Unit for Efficient Optoelectronic Devices - PubMed \[pubmed.ncbi.nlm.nih.gov\]](#)
- [5. lumtec.com.tw \[lumtec.com.tw\]](#)
- [6. N,N'-Bis\(9,9-dimethyl-9H-fluoren-2-yl\)-N,N'-diphenylbenzidine 98.0+%, TCI America 1 g | Buy Online | TCI America | Fisher Scientific \[fishersci.ca\]](#)
- [7. 9,9-Bis\[4-\[\(4-ethenylphenyl\)methoxy\]phenyl\]-N2,N7-di-1-naphthalenyl-N2,N7-diphenyl-9H-Fluorene-2,7-diamine ≥98% \(HPLC\) | Sigma-Aldrich \[sigmaaldrich.com\]](#)
- [8. Methoxydiphenylamine-substituted fluorene derivatives as hole transporting materials: role of molecular interaction on device photovoltaic performance - PMC \[pmc.ncbi.nlm.nih.gov\]](#)
- [9. researchgate.net \[researchgate.net\]](#)
- To cite this document: BenchChem. [Comparative Technical Guide: Dmfl-TPD vs. TPD Hole Mobility]. BenchChem, [2026]. [Online PDF]. Available at: [<https://www.benchchem.com/product/b1601899/docs#comparative-technical-guide-dmfl-tpd-vs-tpd-hole-mobility>]

Disclaimer & Data Validity:

The information provided in this document is for Research Use Only (RUO) and is strictly not intended for diagnostic or therapeutic procedures. While BenchChem strives to provide accurate protocols, we make no warranties, express or implied, regarding the fitness of this product for every specific experimental setup.

Technical Support: The protocols provided are for reference purposes. Unsure if this reagent suits your experiment?

Need Industrial/Bulk Grade? [Request Custom Synthesis Quote](#)

BenchChem

Our mission is to be the trusted global source of essential and advanced chemicals, empowering scientists and researchers to drive progress in science and industry.

Contact

Address: 3281 E Guasti Rd

Ontario, CA 91761, United States

Phone: (601) 213-4426

Email: info@benchchem.com

[Contact our Ph.D. Support Team for a compatibility check](#)