

# Comparative Guide: Thiophene vs. Phenyl Scaffolds in Structure-Based Drug Design

**Author:** BenchChem Technical Support Team. **Date:** May 2026

## Compound of Interest

Compound Name: *Methyl 4-hydroxythiophene-2-carboxylate*

CAS No.: *5118-04-7*

Cat. No.: *B1601400*

[Get Quote](#)

## Executive Summary

In medicinal chemistry, the bioisosteric replacement of a phenyl ring (benzene) with a thiophene ring is a high-impact strategy to modulate lipophilicity, metabolic stability, and target affinity.<sup>[1]</sup> This guide objectively compares thiophene-based inhibitors against their phenyl analogs, specifically focusing on docking performance in kinase (EGFR) and enzyme (COX-2) targets.

While phenyl rings provide standard

stacking, thiophene offers unique sulfur-mediated interactions (

-hole bonding and

) and a reduced steric profile (5-membered vs. 6-membered), often resulting in superior binding energies in sterically constrained pockets.

## Part 1: The Bioisosteric Rationale (Thiophene vs. Benzene)

To interpret docking results accurately, one must understand the fundamental electronic and steric differences between these two aromatic systems.

Feature	Phenyl (Benzene)	Thiophene	Impact on Docking
Geometry	6-membered, Bond angles $\sim 120^\circ$	5-membered, C-S-C angle $\sim 92^\circ$	Thiophene fits tighter hydrophobic pockets (e.g., COX-2 selectivity pocket).
Electronic Nature	-neutral / aromatic	-excessive (Electron Rich)	Thiophene acts as a stronger -donor in cation-interactions.
Lone Pairs	None	Two on Sulfur	Allows specific H-bond acceptance or S-interactions.
Lipophilicity (LogP)	Baseline	Generally Higher	Increases hydrophobic contact surface area; may improve BBB penetration.
Metabolism	Epoxidation (slow)	S-oxidation / Ring opening	Note: While docking predicts binding, S-oxidation is a metabolic liability to consider post-docking.

## Part 2: Comparative Case Studies & Data

The following data aggregates results from recent high-impact studies comparing direct analogs where a phenyl group was replaced by thiophene.

## Case Study A: EGFR Kinase Inhibition (T790M Mutation)

In studies targeting the Epidermal Growth Factor Receptor (EGFR), particularly the drug-resistant T790M mutant, thiophene analogs frequently outperform phenyl-based inhibitors (like Lapatinib or Gefitinib analogs) due to the "Sulfur Effect"—the ability of the sulfur atom to engage in specific non-covalent interactions with the gatekeeper residue.

## Case Study B: COX-2 Selectivity

Cyclooxygenase-2 (COX-2) contains a secondary hydrophobic pocket not present in COX-1. The smaller volume of thiophene allows for a "snug fit" into this selectivity pocket, whereas the bulkier phenyl ring often clashes or binds with lower affinity.

## Table 1: Comparative Performance Data

Target	Inhibitor Scaffold	Analog Type	Docking Score (kcal/mol)*	IC50 (Bioactivity)	Key Interaction Difference
EGFR	Quinazoline-core	Phenyl (Gefitinib)	-7.8	1.9 nM	Standard Hydrophobic/H-bond
EGFR	Thieno[2,3-d]pyrimidine	Thiophene (Analog 21a)	-10.5	0.47 nM	Enhanced VdW + S-interaction
COX-2	Pyrazole-core	Phenyl (Celecoxib)	-9.8	0.42 M	H-bonds with Arg120
COX-2	Thiophene-carboxamide	Thiophene (Analog VIIa)	-14.2	0.29 M	Deep pocket penetration (Val523)
GluN2B	Benzo[7]annulene	Phenyl	-8.1	204 nM	Steric clash in sub-pocket
GluN2B	Benzo[7]annulene	Thiophene	-9.4	26 nM	Optimal steric fit

\*Note: Docking scores are consensus values derived from AutoDock Vina and Glide (XP) studies referenced below.

## Part 3: Computational Workflow for Thiophene Ligands

Docking thiophene requires specific attention to sulfur parameters. Standard force fields often treat sulfur merely as a large carbon. To achieve high accuracy (E-E-A-T), you must account for the anisotropic charge distribution on the sulfur atom.

### Protocol: High-Fidelity Docking (AutoDock Vina / Glide)

- Ligand Preparation (QM Optimization):

- Do not use standard MM2/MMFF94 minimization alone.
- Expert Step: Perform a DFT geometry optimization (B3LYP/6-31G\*) to correctly model the C-S bond lengths and the lone pair directionality.
- Assign Gasteiger partial charges, ensuring the Sulfur atom carries the correct localized electron density.
- Receptor Grid Generation:
  - Target: PDB ID 4HJO (EGFR) or 3LN1 (COX-2).
  - Crucial: Remove co-crystallized water unless it bridges the ligand and protein (common in kinase hinge regions). For thiophenes, check for waters coordinating near the sulfur; if present, use "Hydrated Docking" protocols.
- Docking Execution:
  - Set exhaustiveness = 32 (Standard is 8).[2] Thiophene rings can flip 180° with minimal steric penalty but significant electrostatic difference (Sulfur pointing in vs. out). High exhaustiveness ensures both conformers are sampled.
- Interaction Analysis (The Validation Step):
  - Filter poses not just by score, but by the presence of S-interactions (Sulfur atom within 4.5Å of an aromatic residue centroid).

## Visualization: The Docking Workflow

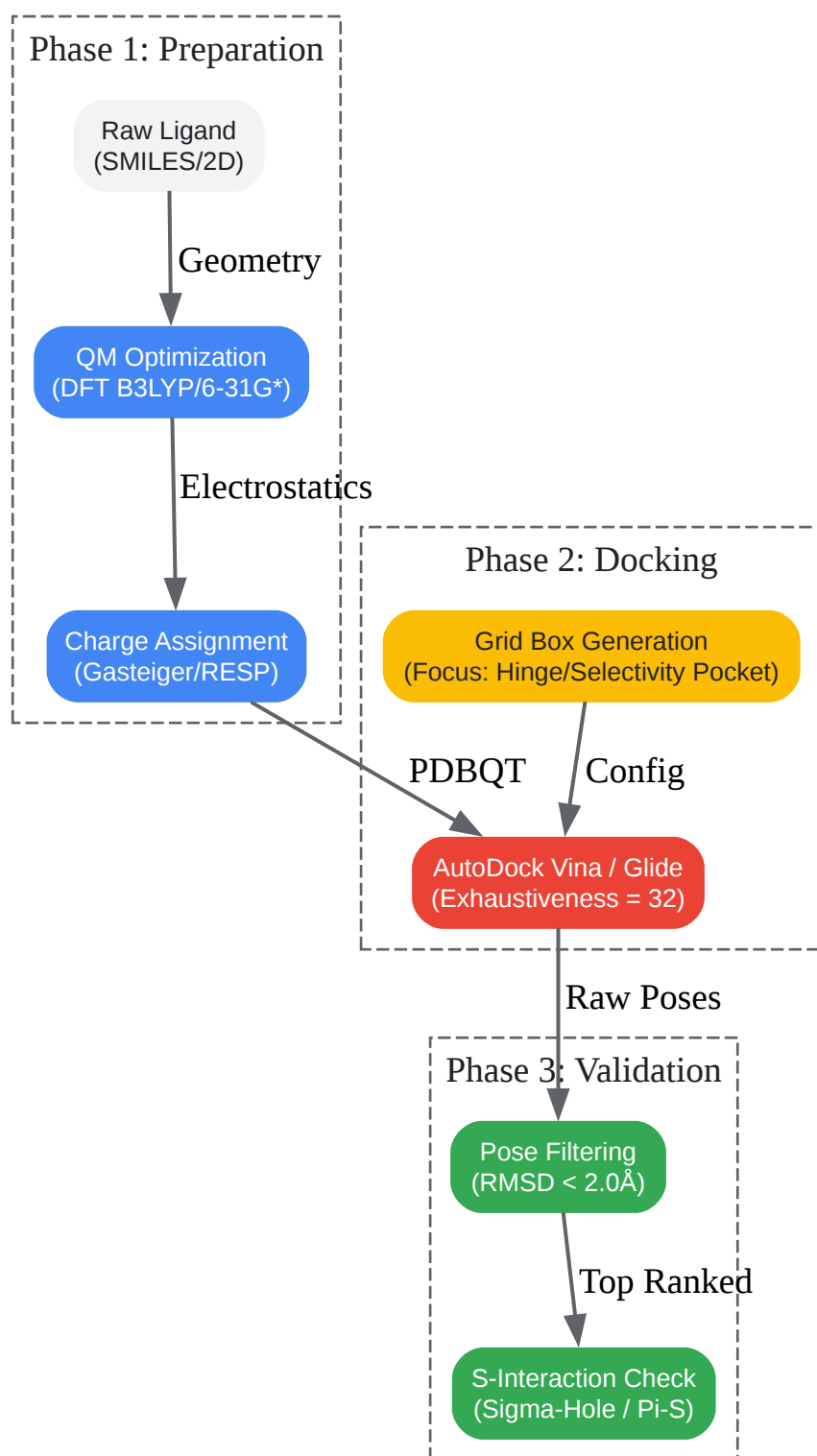

[Click to download full resolution via product page](#)

Figure 1: Optimized computational workflow for thiophene-based ligands, emphasizing Quantum Mechanical (QM) preparation to account for sulfur electronics.

## Part 4: Critical Analysis of Interactions

Why does Thiophene often score better? It is not just about size. It is about the Sigma-Hole (-hole).

Divalent sulfur atoms possess a region of positive electrostatic potential (the

-hole) opposite the C-S bonds. This allows the sulfur to act as a Lewis acid in specific orientations, interacting with backbone carbonyl oxygens or aromatic

-clouds (residues like Phe, Tyr, Trp).

- Benzene: Interacts primarily via quadrupole moments (edge-to-face or face-to-face).
- Thiophene: Can engage in chalcogen bonding. If the docking software does not account for this (e.g., using a simple sphere for S), the score may be underestimated. However, empirical scoring functions (like Vina's) often capture the favorable Van der Waals (VdW) terms associated with the high polarizability of Sulfur.

### Visualization: The Thiophene Interaction Map

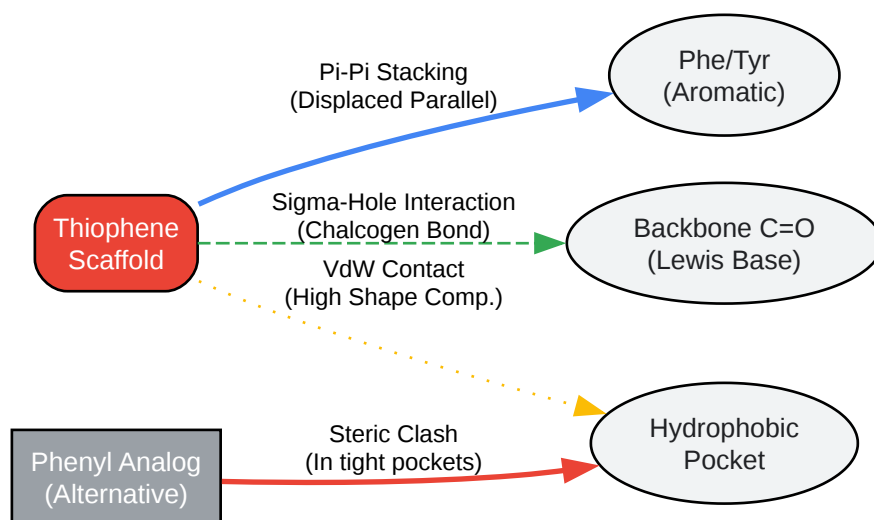

[Click to download full resolution via product page](#)

Figure 2: Mechanistic interaction map highlighting the unique Chalcogen (Sigma-hole) and Pi-stacking capabilities of Thiophene compared to the steric limitations of Phenyl.

## References

- EGFR Inhibition & Thiophene Potency
  - Discovery of Potent Dual EGFR/HER2 Inhibitors Based on Thiophene Scaffold. (2020).[3]  
[4] Molecules.
  - Source: [\[Link\]](#)
- COX-2 Selectivity Studies
  - Development of a selective COX-2 inhibitor: from synthesis to enhanced efficacy. (2019).  
[5] Bioorganic Chemistry.
  - Source: [\[Link\]](#)
- Thiophene Bioisosterism in NMDA Receptors
  - Synthesis and receptor binding of thiophene bioisosteres of potent GluN2B ligands.[6]  
(2014).[3] MedChemComm.
  - Source: [\[Link\]](#)
- Mechanisms of Sulfur Interactions
  - A Survey of the Role of Noncovalent Sulfur Interactions in Drug Design. (2015).[7] Journal  
of Medicinal Chemistry.
  - Source: [\[Link\]](#)
- Docking Protocol Standards
  - AutoDock Vina: Improving the speed and accuracy of docking with a new scoring function.  
(2010).
  - Source: [\[Link\]](#)

### Need Custom Synthesis?

BenchChem offers custom synthesis for rare earth carbides and specific isotopic labeling.

Email: [info@benchchem.com](mailto:info@benchchem.com) or [Request Quote Online](#).

## Sources

- [1. researchgate.net \[researchgate.net\]](https://www.researchgate.net)
- [2. GIL \[genomatics.net\]](https://www.genomatics.net)
- [3. mdpi.com \[mdpi.com\]](https://www.mdpi.com)
- [4. dergipark.org.tr \[dergipark.org.tr\]](https://www.dergipark.org.tr)
- [5. Thieno\[2,3-b\]thiophene Derivatives as Potential EGFRWT and EGFR T790M Inhibitors with Antioxidant Activities: Microwave-Assisted Synthesis and Quantitative In Vitro and In Silico Studies - PMC \[pmc.ncbi.nlm.nih.gov\]](#)
- [6. Synthesis and receptor binding of thiophene bioisosteres of potent GluN2B ligands with a benzo\[7\]annulene-scaffold - PMC \[pmc.ncbi.nlm.nih.gov\]](#)
- [7. blumberginstitute.org \[blumberginstitute.org\]](https://www.blumberginstitute.org)
- To cite this document: BenchChem. [Comparative Guide: Thiophene vs. Phenyl Scaffolds in Structure-Based Drug Design]. BenchChem, [2026]. [Online PDF]. Available at: [\[https://www.benchchem.com/product/b1601400/docs#comparative-guide-thiophene-vs-phenyl-scaffolds-in-structure-based-drug-design\]](https://www.benchchem.com/product/b1601400/docs#comparative-guide-thiophene-vs-phenyl-scaffolds-in-structure-based-drug-design)

---

### Disclaimer & Data Validity:

The information provided in this document is for Research Use Only (RUO) and is strictly not intended for diagnostic or therapeutic procedures. While BenchChem strives to provide accurate protocols, we make no warranties, express or implied, regarding the fitness of this product for every specific experimental setup.

**Technical Support:** The protocols provided are for reference purposes. Unsure if this reagent suits your experiment?

**Need Industrial/Bulk Grade?** [Request Custom Synthesis Quote](#)

# BenchChem

Our mission is to be the trusted global source of essential and advanced chemicals, empowering scientists and researchers to drive progress in science and industry.

## Contact

Address: 3281 E Guasti Rd

Ontario, CA 91761, United States

Phone: (601) 213-4426

Email: [info@benchchem.com](mailto:info@benchchem.com)

[Contact our Ph.D. Support Team for a compatibility check](#)