

# Technical Support Center: Nitration Process Safety & Optimization

**Author:** BenchChem Technical Support Team. **Date:** May 2026

## Compound of Interest

Compound Name: *Tert-butyl 4-fluoro-3-nitrophenylcarbamate*

CAS No.: 332370-72-6

Cat. No.: B1600553

[Get Quote](#)

Status: Operational | Tier: Level 3 (Senior Application Support) Topic: Managing Exothermicity in Nitration Reactions

## Mission Statement

Welcome to the Process Safety Support Center. You are likely here because your nitration reaction is exhibiting thermal instability, poor selectivity, or scaling difficulties. Nitration is one of the most hazardous unit operations in synthesis due to high exothermicity (

) and rapid kinetics.

This guide moves beyond basic "add slowly" advice. We analyze the causality of thermal events and provide self-validating protocols to ensure your process remains within the "Safety Triangle": Heat Generation < Heat Removal < Onset of Decomposition.

## Module 1: Critical Safety & Thermal Runaway Prevention

Q: My reactor temperature spikes uncontrollably after a delay, even though I added the acid slowly. Why?

A: You are likely experiencing "Reagent Accumulation" leading to a thermal runaway. This is a counter-intuitive phenomenon. If your reactor is too cold or mixing is inefficient during addition, the reaction rate (

) is near zero. The nitric acid accumulates unreacted.<sup>[1]</sup> When the temperature eventually rises (or mixing improves), the accumulated mass reacts simultaneously.

The Mechanism of Failure:

- Dosing Phase: Acid is added, but  $k$  is too low for immediate consumption.
- Accumulation: The reactor now contains a high potential energy "battery" of unreacted substrate + acid.
- Trigger: A minor heat bump (e.g., mixing energy) initiates the reaction.
- Runaway: The heat generation rate ( $Q_{gen}$ ) exceeds the cooling capacity ( $Q_{cool}$ ), causing an exponential rise in temperature (Arrhenius behavior).

Visualizing the Hazard:

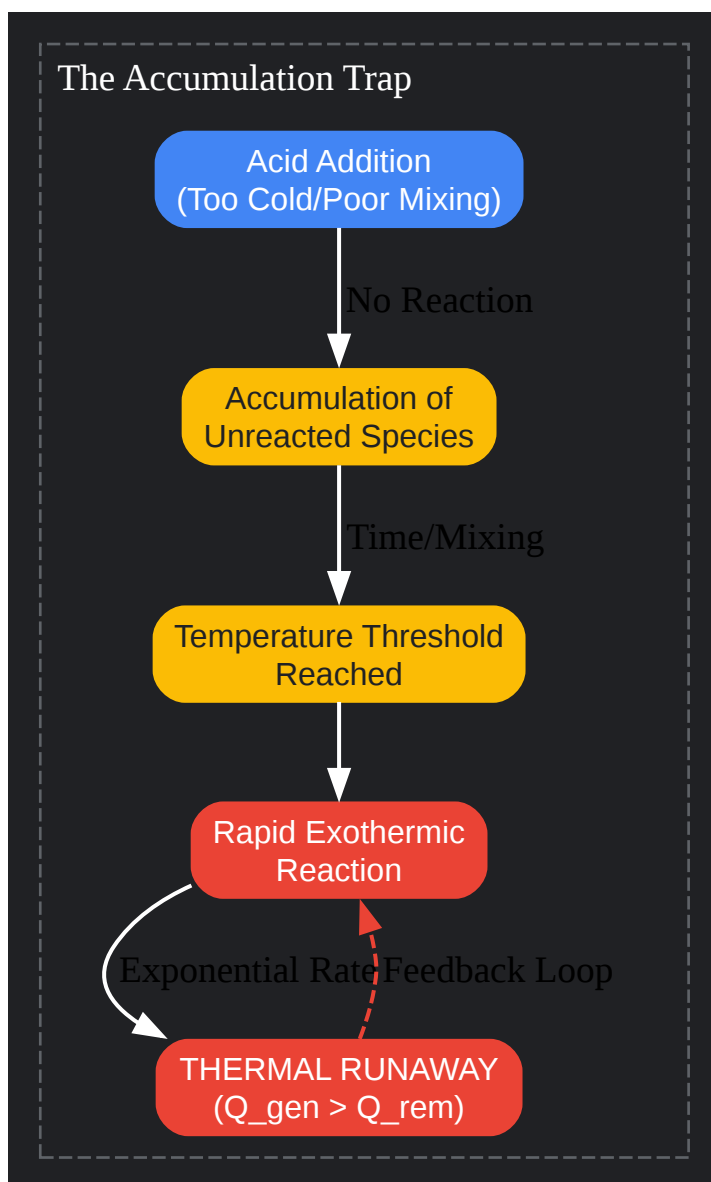

[Click to download full resolution via product page](#)

Figure 1: The "Accumulation Trap" cycle where delayed reaction kinetics lead to catastrophic thermal runaway.

Corrective Protocol: The "Dosing-Consumption" Check

- Stop Dosing: Immediately halt acid addition.
- Verify Consumption: Use in-situ IR or calorimetry. If the heat signal stops immediately when dosing stops, your process is mass-transfer controlled (Safe). If the heat signal continues rising after dosing stops, you have accumulation (Dangerous).

## Module 2: Selectivity & Process Optimization

Q: I am observing significant dinitration and oxidative byproducts (tars). Is this purely a temperature issue?

A: This is often a "Hotspot" issue caused by mixing limitations, not just bulk temperature. In mixed-acid nitrations, the reaction often occurs at the interface of the organic and aqueous acid phases. If the Damköhler number (

) is high (reaction rate > diffusion rate), the local concentration of nitronium ions (

) at the interface effectively becomes super-stoichiometric.

The Causality of Side Reactions:

- **Local Overheating:** The reaction heat is released faster than it can dissipate into the bulk solvent, creating microscopic "hotspots" that favor high-activation-energy side reactions (oxidation).
- **Over-concentration:** Poor mass transfer traps the mono-nitro product in the acid phase, leading to dinitration.

Data: Impact of Mixing on Selectivity

Parameter	Low Mixing ( $Re < 2000$ )	High Mixing ( $Re > 10,000$ )	Mechanism
Local Stoichiometry	High Acid Excess (Interface)	1:1 Homogeneous	Mass Transfer Limit
Heat Dissipation	Slow (Hotspots form)	Rapid (Isothermal)	Convection
Byproduct Profile	Dinitrated + Phenols	Mono-nitro (Target)	Kinetic Control
Safety Risk	High (Accumulation)	Low (Instant Reaction)	Accumulation

Troubleshooting Guide:

- **Impeller Selection:** Switch from a marine propeller (axial flow) to a Rushton turbine (high shear) to break droplets and increase interfacial area.

- Dilution: Use an inert solvent (e.g., Dichloromethane or Sulfolane) to act as a heat sink and dilute the local acid concentration.

### Module 3: Engineering & Scale-Up (Batch vs. Flow)

Q: We cannot scale this reaction beyond 100g because the exotherm overwhelms our chiller. What is the solution?

A: You have hit the "Surface-to-Volume" wall. Transition to Continuous Flow. In a batch reactor, as you scale up, the volume (heat generation source) increases cubically (

), while the cooling surface area increases only quadratically (

). Eventually,

guarantees a runaway.

Why Flow Chemistry Solves This: Continuous flow microreactors or mesoreactors possess massive surface-to-volume ratios (

), allowing heat removal rates that are orders of magnitude higher than batch vessels. This allows you to run "forbidden" chemistries safely.

Visualizing Heat Transfer Efficiency:

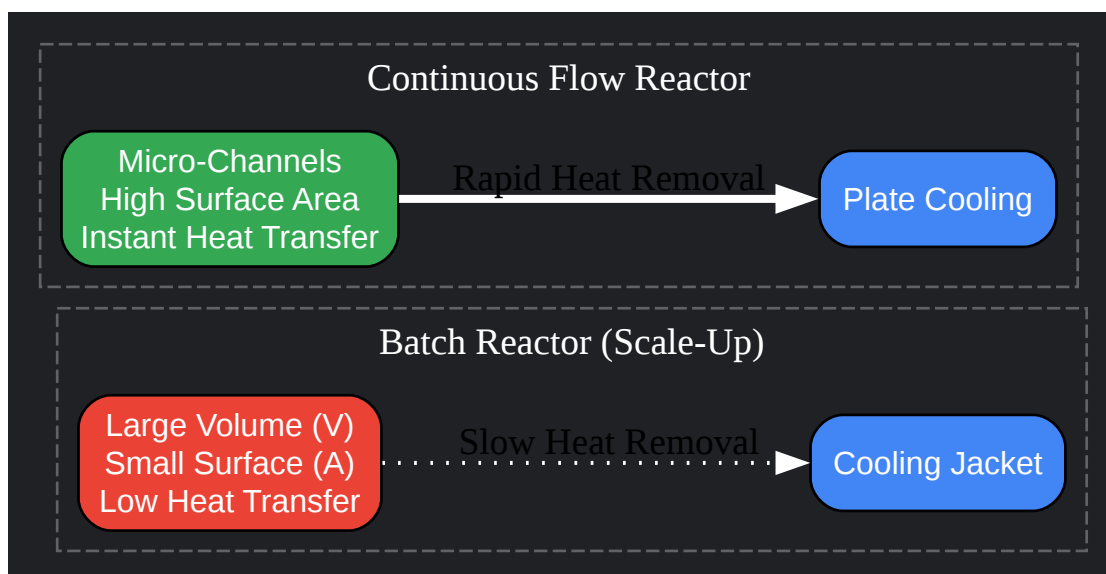

[Click to download full resolution via product page](#)

Figure 2: Comparison of heat transfer limitations in Batch vs. Flow systems. Flow reactors decouple scale from thermal risk.

## Standard Operating Protocols (SOPs)

### Protocol A: Adiabatic Temperature Rise (

### ) Calculation

Before running any nitration >1g, you must calculate the worst-case scenario.

Objective: Determine the maximum temperature the reactor would reach if cooling failed completely.

- Formula:
  - : Enthalpy of reaction (Assume -150 kJ/mol if unknown, or measure via DSC).
  - : Concentration of limiting reagent (mol/L).
  - : Specific heat capacity of the mixture (approx. 1.8 - 2.0 J/g·K for mixed acids).[2]
  - : Density of mixture ( kg/L ).
- Decision Matrix:
  - If  
: Low Risk.
  - If  
: CRITICAL RISK. You must reduce concentration or switch to flow.

### Protocol B: DSC Screening for

Never assume a nitration is stable.

- Preparation: Seal 2-5 mg of the reaction mixture (product + spent acid) in a gold-plated high-pressure crucible.

- Scan: Ramp temperature from 25°C to 350°C at 4°C/min.
- Analysis: Identify the Onset Temperature ( ) of the decomposition exotherm.
- Safety Rule: Your maximum process temperature ( ) must be at least 50°C below

## References

- American Chemical Society (ACS). (2020). Optimization and Scale-Up of the Continuous Flow Acetylation and Nitration of 4-Fluoro-2-methoxyaniline. Organic Process Research & Development. [Link](#)
- Beilstein Journals. (2025). Continuous-flow-enabled intensification in nitration processes: a review. Beilstein Journal of Organic Chemistry. [Link](#)
- National Institutes of Health (NIH). (2014). Continuous flow nitration in miniaturized devices. PMC. [Link](#)
- AIChE. (2023). Advantages and Limitations of a Nitration Reaction Performed in Batch vs. Continuous Mode. American Institute of Chemical Engineers.[3] [Link](#)
- Purdue University/LearnChemE. (2011). Adiabatic Temperature Calculation. [Link](#)

### *Need Custom Synthesis?*

*BenchChem offers custom synthesis for rare earth carbides and specific isotopic labeling.*

*Email: [info@benchchem.com](mailto:info@benchchem.com) or [Request Quote Online](#).*

## Sources

- [1. pdf.benchchem.com](https://pdf.benchchem.com) [[pdf.benchchem.com](https://pdf.benchchem.com)]

- [2. rushim.ru \[rushim.ru\]](https://rushim.ru)
- [3. proceedings.aiche.org \[proceedings.aiche.org\]](https://proceedings.aiche.org)
- To cite this document: BenchChem. [Technical Support Center: Nitration Process Safety & Optimization]. BenchChem, [2026]. [Online PDF]. Available at: [\[https://www.benchchem.com/product/b1600553/docs#technical-support-center-nitration-process-safety-optimization\]](https://www.benchchem.com/product/b1600553/docs#technical-support-center-nitration-process-safety-optimization)

---

### Disclaimer & Data Validity:

The information provided in this document is for Research Use Only (RUO) and is strictly not intended for diagnostic or therapeutic procedures. While BenchChem strives to provide accurate protocols, we make no warranties, express or implied, regarding the fitness of this product for every specific experimental setup.

**Technical Support:** The protocols provided are for reference purposes. Unsure if this reagent suits your experiment?

**Need Industrial/Bulk Grade?** [Request Custom Synthesis Quote](#)

## BenchChem

Our mission is to be the trusted global source of essential and advanced chemicals, empowering scientists and researchers to drive progress in science and industry.

### Contact

Address: 3281 E Guasti Rd  
Ontario, CA 91761, United States  
Phone: (601) 213-4426  
Email: [info@benchchem.com](mailto:info@benchchem.com)

[Contact our Ph.D. Support Team for a compatibility check](#)