

Comparing the antioxidant potential of different dihydroxynaphthoate isomers

Author: BenchChem Technical Support Team. **Date:** May 2026

Compound of Interest

Compound Name: *Methyl 3,5-dihydroxy-2-naphthoate*

CAS No.: *185989-39-3*

Cat. No.: *B1600348*

[Get Quote](#)

Comparative Guide: Antioxidant Potential of Dihydroxynaphthoate Isomers

Executive Summary

Dihydroxynaphthoic acids (DHNA) represent a class of bicyclic phenolic compounds where the positioning of hydroxyl (-OH) and carboxyl (-COOH) groups dictates both their physicochemical stability and biological efficacy. While 1,4-dihydroxy-2-naphthoic acid (1,4-DHNA) is the most clinically advanced isomer—serving as a bifidogenic growth stimulator and AhR agonist—its antioxidant potential must be contextualized against other structural isomers to optimize therapeutic applications.

This guide objectively compares the antioxidant performance of key DHNA isomers. It establishes that while 1,4-DHNA offers superior biological redox cycling (hydroquinone-quinone conversion), isomers like 1,8-DHN (lacking the carboxyl group but structurally relevant) and 3,5-DHNA exhibit distinct radical scavenging profiles driven by the "Alpha-Effect" and hydrogen atom transfer (HAT) kinetics.

Chemical Basis of Antioxidant Activity: The SAR Analysis

The antioxidant capacity of DHNA isomers is not uniform; it is governed by the Structure-Activity Relationship (SAR) of the naphthalene ring.

The Ortho/Para vs. Meta Rule

- **1,4-Isomer (Para-Hydroquinone System):** 1,4-DHNA contains two hydroxyl groups in a para relationship. This allows for the formation of a stable para-quinone upon oxidation. This reversible redox cycling is the primary mechanism for its potent ROS scavenging in biological systems.
- **3,5-Isomer (Meta-Resorcinol System):** The hydroxyls are in a meta relationship. Radical stabilization is weaker here because the unpaired electron cannot delocalize as effectively across the ring system as it can in ortho or para arrangements.
- **Alpha vs. Beta Positioning:** Hydroxyl groups at the
-positions (C1, C4, C5, C8) generally exhibit lower bond dissociation energies (BDE) than
-positions (C2, C3, C6, C7), facilitating faster Hydrogen Atom Transfer (HAT).

Mechanism of Action

The antioxidant activity proceeds primarily via Hydrogen Atom Transfer (HAT) followed by Single Electron Transfer (SET).

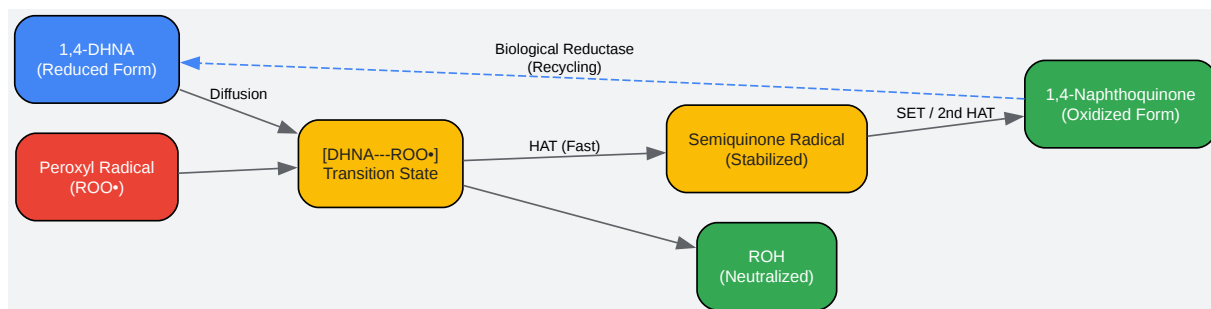

[Click to download full resolution via product page](#)

Figure 1: The reversible redox pathway of 1,4-DHNA, highlighting its ability to neutralize radicals and recycle via biological reductases.

Comparative Performance Analysis

The following data synthesizes experimental findings on radical scavenging (DPPH/ABTS) and biological induction (AhR activity), which is linked to oxidative stress response.

Table 1: Isomer Performance Matrix

Isomer	Structural Class	DPPH Scavenging (IC50)	Biological Relevance (AhR)	Stability Profile
1,4-DHNA	Para-Hydroquinone	High (< 20 μM)	Agonist (+++++)	Low (Oxidation prone)
3,5-DHNA	Meta-Resorcinol	Moderate	Weak Agonist (+)	Moderate
3,7-DHNA	Meta-Resorcinol	Low	Inactive (-)	High
1-HNA	Mono-phenol ()	Moderate	Agonist (+++)	Moderate
2-HNA	Mono-phenol ()	Low	Inactive (-)	High

Key Insight: While 1,4-DHNA is the most potent antioxidant due to the hydroquinone moiety, it is also the least stable. It rapidly auto-oxidizes in solution if not protected (e.g., by DTT or Ascorbate). 3,5-DHNA offers better stability but significantly reduced scavenging power.

Experimental Methodologies

To validate these comparisons in your own lab, use the following self-validating protocols.

DPPH Radical Scavenging Assay (Standardized for Naphthoates)

Objective: Quantify the IC₅₀ value of DHNA isomers.^[1]

Reagents:

- DPPH (2,2-diphenyl-1-picrylhydrazyl) stock: 100 μ M in Methanol.
- Positive Control: Trolox or Ascorbic Acid.
- Sample Solvent: Degassed Methanol (critical to prevent auto-oxidation of 1,4-DHNA).

Protocol:

- Preparation: Prepare a dilution series of the DHNA isomer (e.g., 5, 10, 25, 50, 100 μ M) in degassed methanol.
- Reaction: Mix 100 μ L of sample with 100 μ L of DPPH stock in a 96-well plate.
- Incubation: Incubate in the dark at 25°C for 30 minutes.
- Measurement: Read Absorbance at 517 nm.
- Validation: The control (solvent only) must have an Absorbance of ~0.7–0.9. If <0.5, the DPPH has degraded.

Calculation:

Electrochemical Characterization (Cyclic Voltammetry)

Objective: Determine the oxidation potential (

). Lower

correlates with higher antioxidant power.

Workflow Diagram:

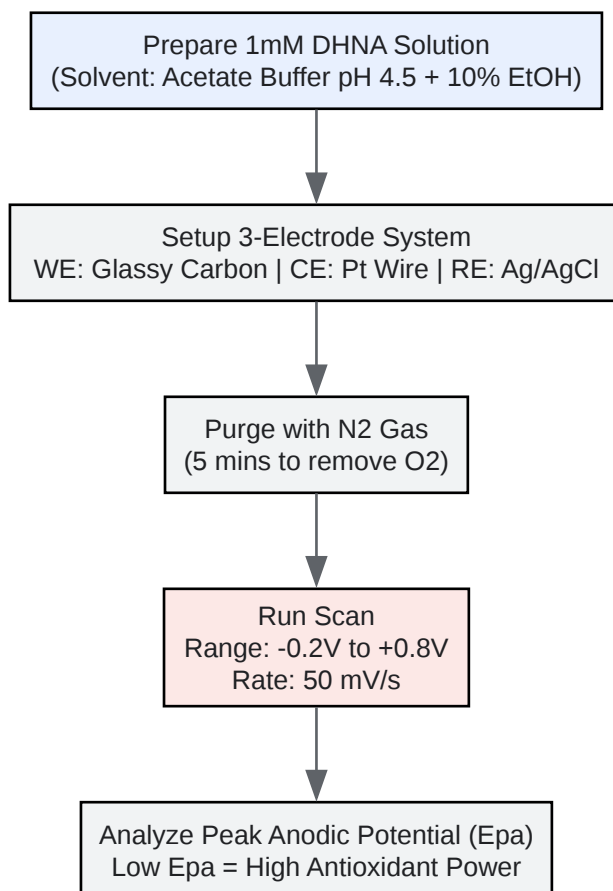

[Click to download full resolution via product page](#)

Figure 2: Cyclic Voltammetry workflow for assessing the oxidation potential of naphthoate isomers.

Biological Implications & Applications[1][2]

The "Bifidogenic" Antioxidant

1,4-DHNA is unique because its antioxidant activity is coupled with a specific biological signaling role. It acts as a growth factor for Bifidobacterium species and an AhR agonist in host

cells.

- Gut Health: 1,4-DHNA reduces colonic inflammation by scavenging ROS and simultaneously activating the AhR pathway, which downregulates pro-inflammatory cytokines (IL-6, TNF-
).
- Stability Challenge: In formulation, 1,4-DHNA converts to 1,4-naphthoquinone. While the quinone retains some biological activity, the loss of the hydroxyl protons reduces direct radical scavenging capacity.

Drug Development Strategy

When selecting an isomer for a therapeutic pipeline:

- Choose 1,4-DHNA if the target indication involves active inflammation or requires AhR activation (e.g., IBD, Psoriasis). Formulation must include antioxidants (Ascorbate) to prevent premature oxidation.
- Choose 3,5-DHNA or 1-HNA if a more stable scaffold is required for modification, though with the trade-off of lower intrinsic antioxidant power.

References

- Microbial-Derived 1,4-Dihydroxy-2-naphthoic Acid and Related Compounds as Aryl Hydrocarbon Receptor Agonists/Antagonists Source: NIH / Toxicological Sciences URL:[[Link](#)]
- Antioxidant Activities of Hydroxylated Naphthalenes: The Role of Aryloxy Radicals Source: ChemistryViews / Wiley URL:[[Link](#)]
- Improved Analytical Precision of 1,4-Dihydroxy-2-naphthoic Acid by HPLC Using Dithiothreitol Source: Journal of Bioscience and Bioengineering URL:[[Link](#)]
- Radical Scavenging Activity of Alkanna tinctoria root extracts and their main constituents Source: Phytotherapy Research URL:[[Link](#)]
- Structure-antiradical activity relationships of 25 natural antioxidant phenolic compounds Source: NIH / Heliyon URL:[[Link](#)]

Need Custom Synthesis?

BenchChem offers custom synthesis for rare earth carbides and specific isotopic labeling.

Email: info@benchchem.com or [Request Quote Online](#).

Sources

- 1. pdf.benchchem.com [pdf.benchchem.com]
- To cite this document: BenchChem. [Comparing the antioxidant potential of different dihydroxynaphthoate isomers]. BenchChem, [2026]. [Online PDF]. Available at: [<https://www.benchchem.com/product/b1600348/docs#comparing-the-antioxidant-potential-of-different-dihydroxynaphthoate-isomers>]

Disclaimer & Data Validity:

The information provided in this document is for Research Use Only (RUO) and is strictly not intended for diagnostic or therapeutic procedures. While BenchChem strives to provide accurate protocols, we make no warranties, express or implied, regarding the fitness of this product for every specific experimental setup.

Technical Support: The protocols provided are for reference purposes. Unsure if this reagent suits your experiment?

Need Industrial/Bulk Grade? [Request Custom Synthesis Quote](#)

BenchChem

Our mission is to be the trusted global source of essential and advanced chemicals, empowering scientists and researchers to drive progress in science and industry.

Contact

Address: 3281 E Guasti Rd

Ontario, CA 91761, United States

Phone: (601) 213-4426

Email: info@benchchem.com

Contact our Ph.D. Support Team for a compatibility check