

# Chiral Building Blocks for Phenylethanolamine Drug Synthesis: A Technical Guide

**Author:** BenchChem Technical Support Team. **Date:** April 2026

## Compound of Interest

Compound Name: *tert-Butyl (2-hydroxy-2-(m-tolyl)ethyl)carbamate*

CAS No.: 1026555-76-9

Cat. No.: B1600195

[Get Quote](#)

## Abstract

Phenylethanamines are a critical class of pharmaceuticals, encompassing widely used adrenergic agonists and  $\beta$ -blockers. Their therapeutic efficacy and safety are intrinsically linked to the specific stereochemistry at the carbinol center. Consequently, the development of efficient and stereoselective synthetic routes to access single-enantiomer phenylethanamines is of paramount importance in medicinal chemistry and process development. This technical guide provides an in-depth exploration of the core chiral building blocks and synthetic strategies employed to construct this vital pharmacophore. We will delve into the preparation and application of key chiral intermediates, including epoxides, cyanohydrins,  $\alpha$ -amino ketones, and amino acid derivatives, explaining the causality behind strategic synthetic choices. Detailed protocols, comparative data, and mechanistic diagrams are provided to serve as a practical resource for researchers, scientists, and drug development professionals.

## Introduction: The Primacy of Chirality in Phenylethanamines

The phenylethanolamine scaffold, characterized by a phenyl ring, an ethanolamine side chain, and at least one stereocenter at the hydroxyl-bearing carbon, is the foundation for numerous blockbuster drugs.[1][2] For instance, in  $\beta$ -blockers like metoprolol and propranolol, the (S)-enantiomer is responsible for the desired  $\beta$ 1-adrenergic blocking activity, while the (R)-enantiomer is significantly less active and may contribute to side effects.[1] Similarly, the stimulant effects of synthetic cathinones are often highly enantioselective.[3][4]

This stereospecificity of drug-receptor interactions underscores the necessity of moving beyond racemic mixtures to develop single-enantiomer drugs.[1][5] The synthesis of enantiomerically pure phenylethanolamines relies on two primary strategies: the resolution of a racemic mixture or, more efficiently, asymmetric synthesis using a chiral starting material or catalyst. This guide focuses on the latter, exploring the universe of chiral building blocks that serve as versatile and reliable precursors.

## The Phenylethanolamine Scaffold

The core structure of a phenylethanolamine features a critical stereocenter. The absolute configuration at this carbinol carbon dictates the molecule's three-dimensional arrangement and its ability to bind to its biological target.

Caption: The core phenylethanolamine structure highlighting the critical stereocenter (C\*).

## Key Strategy 1: Chiral Epoxides from Asymmetric Epoxidation

Chiral epoxides are arguably one of the most powerful and versatile building blocks for phenylethanolamine synthesis. Their utility stems from the predictable and highly regioselective ring-opening by amines at the less hindered benzylic carbon, directly installing the required amino alcohol functionality with a defined stereochemistry.

## Generation of Chiral Styrene Oxides

The primary route to these building blocks is the asymmetric epoxidation of styrenic olefins.

- **Jacobsen-Katsuki Epoxidation:** This method is exceptionally effective for unfunctionalized alkenes like styrene. It employs a chiral (salen)manganese(III) complex, known as

Jacobsen's catalyst, to deliver an oxygen atom with high enantioselectivity.[6] The choice of oxidant (e.g., m-CPBA or NaOCl) and additives can be tuned to optimize the reaction.[6]

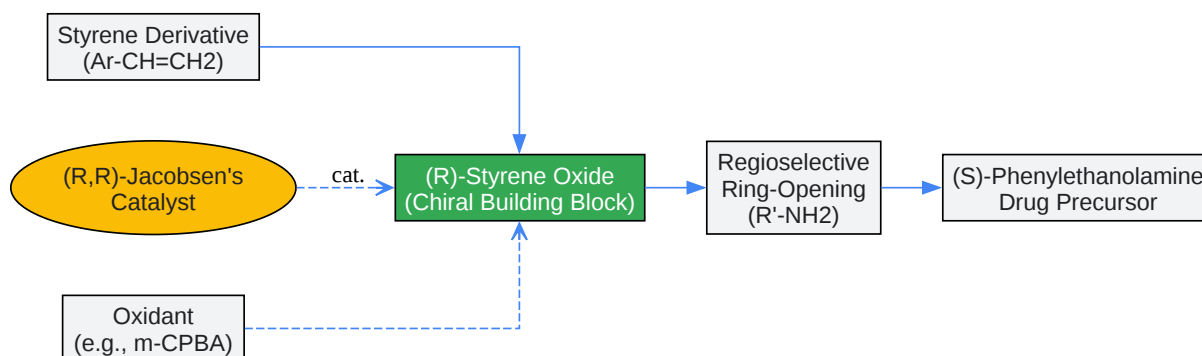

[Click to download full resolution via product page](#)

Caption: Workflow for phenylethanolamine synthesis via Jacobsen epoxidation.

- Sharpless Asymmetric Epoxidation: While the Jacobsen epoxidation is ideal for simple styrenes, the Sharpless epoxidation is the method of choice for allylic alcohols.[7][8] This reaction uses a titanium tetra(isopropoxide) catalyst in conjunction with a chiral diethyl tartrate (DET) ligand.[9][10] By choosing either (+)-DET or (-)-DET, chemists can predictably control the facial selectivity of the epoxidation, yielding either enantiomer of the resulting epoxy alcohol.[8]

## Application in Drug Synthesis

The synthesis of the  $\beta$ -blocker (S)-Metoprolol can be achieved using a chiral epoxide intermediate. The key step is the nucleophilic attack of the isopropylamine on the epoxide, which proceeds with high regioselectivity and inversion of configuration.

## Key Strategy 2: Asymmetric Reduction of Prochiral Ketones

An alternative and highly convergent approach involves the asymmetric reduction of a prochiral  $\alpha$ -functionalized ketone. This strategy forges the chiral carbinol center directly in the penultimate or final steps of the synthesis.

## Asymmetric Hydrogenation of $\alpha$ -Amino Ketones

The direct asymmetric hydrogenation of  $\alpha$ -amino ketones is a highly atom-economical method for producing chiral 1,2-amino alcohols.<sup>[11]</sup> This transformation typically employs chiral transition metal catalysts, such as those based on rhodium, iridium, or cobalt, paired with sophisticated chiral phosphine ligands.<sup>[12][13][14]</sup>

Table 1: Comparison of Catalytic Systems for Asymmetric Hydrogenation of  $\alpha$ -Amino Ketones

Catalyst System	Substrate Example	Yield (%)	Enantiomeric Excess (ee, %)	Reference
[Ir(COD)Cl] <sub>2</sub> / Chiral Spiro Ligand	$\alpha$ -Aminoacetophenone	>95	up to 99.9	[11]
Co-Complex / Chiral Phosphine	Substituted $\alpha$ -Amino Ketones	90-99	84-99	[12]
Rh / Electron-Donating Phosphine	Unprotected $\alpha$ -Amino Ketones	Good	Good	[14]

The high efficiency and enantioselectivity of these systems make them attractive for industrial-scale synthesis.<sup>[12]</sup>

## Biocatalytic Reductions

Biocatalysis offers a green and highly selective alternative to metal-based catalysts. Ketoreductases (KREDs) from various microorganisms can reduce  $\alpha$ -haloketones or  $\alpha$ -azidoketones to their corresponding chiral alcohols with exceptional enantiopurity.

For example, strains of *Lactobacillus curvatus* have been used for the asymmetric reduction of 2-bromo-1-(naphthalen-2-yl)ethanone to produce (R)-2-bromo-1-(naphthalen-2-yl)ethanol, a

precursor for  $\beta$ -blockers, in high yield and >99% ee.[15]

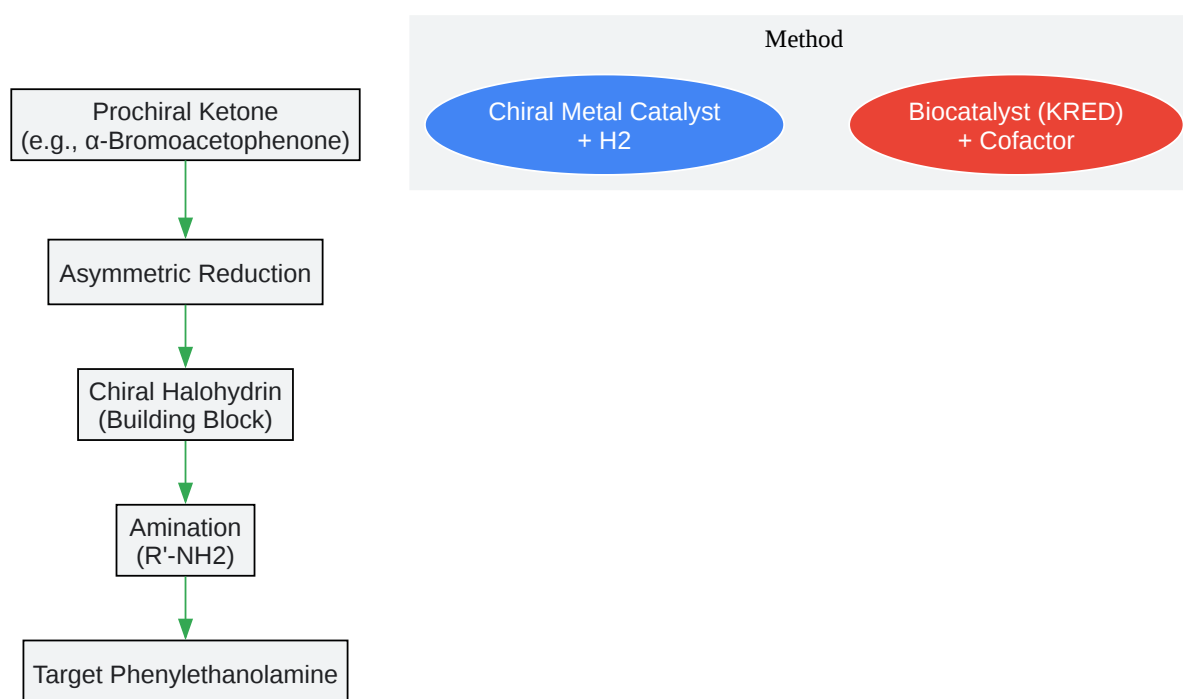

[Click to download full resolution via product page](#)

Caption: Synthetic routes via asymmetric reduction of prochiral ketones.

## Key Strategy 3: The Chiral Pool Approach

The "chiral pool" refers to the collection of inexpensive, enantiomerically pure natural products that can be used as starting materials. For phenylethanolamine synthesis, amino acids and  $\alpha$ -hydroxy acids are particularly valuable.

## Mandelic Acid Derivatives

Mandelic acid, an aromatic  $\alpha$ -hydroxy acid, is a readily available and versatile chiral building block.<sup>[16][17][18]</sup> Its enantiomers can serve as chiral synthons for a variety of pharmaceuticals.<sup>[16][18]</sup> The carboxylic acid and hydroxyl groups provide handles for a wide range of chemical transformations, allowing for the construction of the ethanolamine side chain.

## Phenylalanine and Other Amino Acids

Naturally occurring L-phenylalanine can be converted into valuable intermediates.<sup>[19][20]</sup> For example, enzymatic cascades can transform L-phenylalanine into 2-phenylethanol or phenylacetic acid, which can then be further elaborated into the target drug molecules.<sup>[19][20]</sup>

## Key Strategy 4: Kinetic Resolution

Kinetic resolution is a powerful technique for separating a racemic mixture. It relies on the differential reaction rate of two enantiomers with a chiral catalyst or reagent.

### Enzymatic Kinetic Resolution

Lipases are frequently used enzymes for the kinetic resolution of racemic alcohols or amines.<sup>[21][22]</sup> For instance, *Candida antarctica* lipase B (CAL-B, often immobilized as Novozym 435) is highly effective at acylating one enantiomer of a racemic alcohol, leaving the other unreacted and enantiopure.<sup>[22][23]</sup> This method is widely used for producing chiral 1-phenylethanol.<sup>[22]</sup>

A significant advancement is Dynamic Kinetic Resolution (DKR), where the unreacted enantiomer is racemized in situ.<sup>[21]</sup> This allows for a theoretical yield of 100% of a single enantiomer, overcoming the 50% yield limitation of standard kinetic resolution.<sup>[21]</sup>

Table 2: Representative Enzymatic Resolutions

Substrate	Enzyme	Method	Product	Yield (%)	ee (%)	Reference
(±)-1-Phenylethylamine	CAL-B + Ru-catalyst	DKR	(R)-Amide	Good	High	[21]
(±)-1-Phenylethanol	Novozym 435	Kinetic Resolution	(S)-1-Phenylethanol	~50	>99	[22][24]
Racemic Amines	CAL-B	Kinetic Resolution	Enantiopure Amine	Good	>99	[23]

## Experimental Protocols

To ensure this guide is of practical value, a representative, self-validating protocol is provided below.

### Protocol: Jacobsen Epoxidation of Styrene

This protocol describes a general procedure for the enantioselective epoxidation of styrene using (R,R)-Jacobsen's catalyst.[6]

Materials:

- Styrene
- (R,R)-(-)-N,N'-Bis(3,5-di-tert-butylsalicylidene)-1,2-cyclohexanediaminomanganese(III) chloride (Jacobsen's catalyst)
- meta-Chloroperoxybenzoic acid (m-CPBA, ~77%)
- N-Methylmorpholine N-oxide (NMO)
- Dichloromethane (CH<sub>2</sub>Cl<sub>2</sub>, anhydrous)
- Silica gel for column chromatography

- Standard solvents for workup and chromatography (Hexanes, Ethyl Acetate)
- Saturated aqueous solutions of  $\text{NaHCO}_3$ ,  $\text{Na}_2\text{S}_2\text{O}_3$ , and  $\text{NaCl}$  (brine)
- Anhydrous  $\text{Na}_2\text{SO}_4$  or  $\text{MgSO}_4$

Procedure:

- **Reaction Setup:** In a dry round-bottom flask under an inert atmosphere, dissolve Jacobsen's catalyst (0.02-0.05 equivalents) in anhydrous dichloromethane.
- **Addition of Substrate:** To the stirred solution, add styrene (1.0 equivalent) followed by N-methylmorpholine N-oxide (NMO, 1.5 equivalents).[6]
- **Cooling:** Cool the reaction mixture to 0 °C using an ice bath.
- **Addition of Oxidant:** Slowly add a solution of m-CPBA (1.2 equivalents) in dichloromethane to the reaction mixture over 30-60 minutes. Maintain the temperature at 0 °C.
- **Reaction Monitoring:** Monitor the reaction progress by thin-layer chromatography (TLC) until the starting material is consumed.
- **Quenching:** Upon completion, quench the reaction by adding a saturated aqueous solution of  $\text{Na}_2\text{S}_2\text{O}_3$  to destroy excess oxidant.
- **Work-up:** Transfer the mixture to a separatory funnel. Wash the organic layer sequentially with saturated aqueous  $\text{NaHCO}_3$  and brine.
- **Drying and Concentration:** Dry the organic layer over anhydrous  $\text{Na}_2\text{SO}_4$ , filter, and concentrate the solvent under reduced pressure.
- **Purification:** Purify the crude product (styrene oxide) by flash column chromatography on silica gel.
- **Characterization:** Determine the enantiomeric excess (ee) of the product by chiral HPLC or GC analysis.

## Conclusion

The synthesis of enantiomerically pure phenylethanolamine drugs is a cornerstone of modern pharmaceutical development. The choice of a specific chiral building block and synthetic strategy depends on factors such as substrate scope, desired stereoisomer, cost, scalability, and environmental impact. Asymmetric epoxidation of styrenes provides a powerful route to chiral epoxides, while the asymmetric reduction of prochiral ketones offers a highly convergent and atom-economical alternative. Furthermore, the use of biocatalysis and kinetic resolution techniques continues to provide green and highly selective methods for accessing these critical chiral intermediates. A thorough understanding of these diverse strategies empowers chemists to design and execute efficient and robust syntheses of vital medicines.

## References

- Application Notes and Protocols for the Enantioselective Epoxidation of Styrene using Jacobsen's Catalyst. Benchchem.
- Silva, J., et al. (2022). From Psychoactivity to Antimicrobial Agents: Multifaceted Applications of Synthetic Cathinones and *Catha edulis* Extracts. MDPI.
- Bäckvall, J.-E., et al. (2010). Development of dynamic kinetic resolution on large scale for ( $\pm$ )-1-phenylethylamine. *Beilstein Journal of Organic Chemistry*.
- Gotor, V., et al. (2007). Enzymatic enantiomeric resolution of phenylethylamines structurally related to amphetamine. *Organic & Biomolecular Chemistry*.
- Reddy, K. L., et al. (2011). Concise Synthesis of Two  $\beta$ -Adrenergic Blocking Agents in High Stereoselectivity Using the Readily Available Chiral Building Block (2*S*,2'*S*,2''*S*)-Tris-(2,3-epoxypropyl)-isocyanurate. *Organic Process Research & Development*.
- Chandrasekhar, S., et al. (2011). Asymmetric synthesis of  $\beta$ -adrenergic blockers through multistep one-pot transformations involving in situ chiral organocatalyst formation. *Chemistry – A European Journal*.
- Młynarski, J., & Paradowska, J. (2020). New Advances in the Synthetic Application of Enantiomeric 1-Phenylethylamine ( $\alpha$ -PEA): Privileged Chiral Inducer and Auxiliary. *Molecules*.
- Banerjee, A., & Mitra, A. K. (2026). Unlocking the potential of mandelic acid derivatives: chemical and biological applications – a comprehensive review. *RSC Advances*.
- Jacobsen's catalyst. Wikipedia.
- Enantioselective Synthesis of Both Enantiomers of Cathinone via the Microbiological Reduction of 2-Azido-1-phenyl-1-propanone. *The Journal of Organic Chemistry*.
- Synthesis of mandelic acid-derived chiral ligand 123. ResearchGate.

- Examples of different  $\beta$ -blockers containing a common building block and chiral center. ResearchGate.
- Jacobsen-Katsuki Epoxidations. Wipf Group, University of Pittsburgh.
- Unlocking the potential of mandelic acid derivatives: chemical and biological applications – a comprehensive review. RSC Publishing.
- Sahin, E., et al. (2020). Bio-catalytic asymmetric synthesis of  $\beta$ -adrenergic receptor blocker precursor. Journal of Enzyme Inhibition and Medicinal Chemistry.
- Wu, S., et al. (2020). Efficient Synthesis of Phenylacetate and 2-Phenylethanol by Modular Cascade Biocatalysis. ChemBioChem.
- A structural study into halogenated derivatives of mandelic acid as building blocks of chiral coordination polymers. Taylor & Francis Online.
- Battaglia, V., et al. Asymmetric Organocatalysed Synthesis of (R)-Mandelic Acid Esters and  $\alpha$ -Alkoxy Derivatives from Commercial Aldehydes. Chemistry – A European Journal.
- Silva, J. P., et al. (2022). Synthetic Cathinones: Recent Developments, Enantioselectivity Studies and Enantioseparation Methods. Molecules.
- Yildirim, D., et al. (2019). The production of enantiomerically pure 1-phenylethanol by enzymatic kinetic resolution method using response surface methodology. Preparative Biochemistry & Biotechnology.
- Enantioselective Epoxide Ring Opening of Styrene Oxide with Jacobsen's Salen(Co) Catalyst. mmore500.
- Efficient Synthesis of Phenylacetate and 2-Phenylethanol by Modular Cascade Biocatalysis. Wiley Online Library.
- Jacobsen's catalyst anchored on Al-MCM-41 and NH<sub>2</sub> group modified Si-MCM-41 as heterogeneous enantioselective epoxidation. Redalyc.
- A new method for the synthesis of important building blocks – enantiomerically pure  $\beta$ -methyl-phenylethylamines. V.P. Kukhar Institute of Bioorganic Chemistry and Petrochemistry of the NAS of Ukraine.
- Synthesis of  $\beta$ -Adrenergic Blockers. Synfacts.
- Synthetic Cathinones: Recent Developments, Enantioselectivity Studies and Enantioseparation Methods. PubMed.
- 2-Phenethylamines in Medicinal Chemistry: A Review. MDPI.
- A Technical Guide to Chiral Building Blocks in Synthesis. BenchChem.
- Zhang, X., et al. (2020). Cobalt-Catalyzed Efficient Asymmetric Hydrogenation of  $\alpha$ -Primary Amino Ketones. Organic Letters.
- General beta-blocker structure (aryloxypropanolamines). ResearchGate.
- Recommended Methods for the Identification and Analysis of Synthetic Cathinones in Seized Materials. United Nations Office on Drugs and Crime.
- Sharpless epoxidation. Wikipedia.

- Lipase-Mediated Dynamic Kinetic Resolution of 1-Phenylethanol Using Niobium Salts as Racemization Agents. SciELO.
- Xu, D. G., et al. (2022). Study on Synthesis of 1-Phenylethyl Acetate by Enzymatic Kinetic Resolution. Open Access Library Journal.
- Asymmetric Hydrogenation Methods for the Synthesis of Chiral Molecules. IntechOpen.
- Asymmetric Hydrogenation of  $\alpha$ -Amino Ketones 2 with Ir- (R)-1c a. ResearchGate.
- Asymmetric hydrogenation of  $\alpha$ -secondary-amino ketones. ResearchGate.
- (R)-1-Phenylethylamine as chiral auxiliary in the diastereoselective synthesis of tetrahydro- $\beta$ -carboline derivatives. Academia.edu.
- Synthesis of Chiral 2-Amino-1-Phenylethanol. Catalysis of Organic Reactions.
- Chiral Building Blocks Selection. Enamine.
- Sharpless Asymmetric Epoxidation. Dalal Institute.
- Zhang, X., et al. (2005). Asymmetric hydrogenation of alpha-primary and secondary amino ketones: efficient asymmetric syntheses of (-)-arbutamine and (-)-denopamine. The Journal of Organic Chemistry.
- Conformationally defined adrenergic agents. Part 13. Synthesis of benzobicyclo[3.2.1]octanes involving inversion of configuration via an N-to-O acetyl migration. The Journal of Organic Chemistry.
- ChemInform Abstract:  $\alpha$ -Phenylethylamine-Based Chiral Phospholidines; New Agents for the Determination of the Enantiomeric Excess of Chiral Alcohols, Amines and Thiols by Means of  $^{31}\text{P}$  NMR. ResearchGate.
- Biocatalysis for the synthesis of pharmaceuticals and pharmaceutical intermediates. Zhao Group @ UIUC.
- Sharpless Asymmetric Epoxidation Reaction. Chem 115 Myers.
- Sharpless Asymmetric Epoxidation: Applications in the Synthesis of Bioactive Natural Products. Bentham Science.
- Phenylethanolamine. Wikipedia.
- Sharpless Epoxidation. Organic Chemistry Portal.

### Need Custom Synthesis?

BenchChem offers custom synthesis for rare earth carbides and specific isotopic labeling.

Email: [info@benchchem.com](mailto:info@benchchem.com) or [Request Quote Online](#).

## Sources

- [1. pubs.acs.org \[pubs.acs.org\]](https://pubs.acs.org)

- [2. researchgate.net \[researchgate.net\]](#)
- [3. Synthetic Cathinones: Recent Developments, Enantioselectivity Studies and Enantioseparation Methods - PMC \[pmc.ncbi.nlm.nih.gov\]](#)
- [4. Synthetic Cathinones: Recent Developments, Enantioselectivity Studies and Enantioseparation Methods - PubMed \[pubmed.ncbi.nlm.nih.gov\]](#)
- [5. Chiral Building Blocks Selection - Enamine \[enamine.net\]](#)
- [6. pdf.benchchem.com \[pdf.benchchem.com\]](#)
- [7. Sharpless epoxidation - Wikipedia \[en.wikipedia.org\]](#)
- [8. Sharpless Epoxidation \[organic-chemistry.org\]](#)
- [9. dalalinstitute.com \[dalalinstitute.com\]](#)
- [10. eurekaselect.com \[eurekaselect.com\]](#)
- [11. researchgate.net \[researchgate.net\]](#)
- [12. Cobalt-Catalyzed Efficient Asymmetric Hydrogenation of  \$\alpha\$ -Primary Amino Ketones - PMC \[pmc.ncbi.nlm.nih.gov\]](#)
- [13. Asymmetric Hydrogenation Methods for the Synthesis of Chiral Molecules \[ajchem-b.com\]](#)
- [14. Asymmetric hydrogenation of alpha-primary and secondary amino ketones: efficient asymmetric syntheses of \(-\)-arbutamine and \(-\)-denopamine - PubMed \[pubmed.ncbi.nlm.nih.gov\]](#)
- [15. tandfonline.com \[tandfonline.com\]](#)
- [16. Unlocking the potential of mandelic acid derivatives: chemical and biological applications – a comprehensive review - RSC Advances \(RSC Publishing\) DOI:10.1039/D5RA07369C \[pubs.rsc.org\]](#)
- [17. researchgate.net \[researchgate.net\]](#)
- [18. Unlocking the potential of mandelic acid derivatives: chemical and biological applications – a comprehensive review - RSC Advances \(RSC Publishing\) \[pubs.rsc.org\]](#)
- [19. Efficient Synthesis of Phenylacetate and 2-Phenylethanol by Modular Cascade Biocatalysis - PubMed \[pubmed.ncbi.nlm.nih.gov\]](#)
- [20. researchgate.net \[researchgate.net\]](#)
- [21. BJOC - Development of dynamic kinetic resolution on large scale for \( \$\pm\$ \)-1-phenylethylamine \[beilstein-journals.org\]](#)

- [22. The production of enantiomerically pure 1-phenylethanol by enzymatic kinetic resolution method using response surface methodology - PMC \[pmc.ncbi.nlm.nih.gov\]](#)
- [23. Enzymatic enantiomeric resolution of phenylethylamines structurally related to amphetamine - Organic & Biomolecular Chemistry \(RSC Publishing\) \[pubs.rsc.org\]](#)
- [24. Study on Synthesis of 1-Phenylethyl Acetate by Enzymatic Kinetic Resolution \[scirp.org\]](#)
- To cite this document: BenchChem. [Chiral Building Blocks for Phenylethanolamine Drug Synthesis: A Technical Guide]. BenchChem, [2026]. [Online PDF]. Available at: [\[https://www.benchchem.com/product/b1600195/docs#chiral-building-blocks-for-phenylethanolamine-drug-synthesis-a-technical-guide\]](https://www.benchchem.com/product/b1600195/docs#chiral-building-blocks-for-phenylethanolamine-drug-synthesis-a-technical-guide)

---

### Disclaimer & Data Validity:

The information provided in this document is for Research Use Only (RUO) and is strictly not intended for diagnostic or therapeutic procedures. While BenchChem strives to provide accurate protocols, we make no warranties, express or implied, regarding the fitness of this product for every specific experimental setup.

**Technical Support:** The protocols provided are for reference purposes. Unsure if this reagent suits your experiment?

**Need Industrial/Bulk Grade?** [Request Custom Synthesis Quote](#)

## BenchChem

Our mission is to be the trusted global source of essential and advanced chemicals, empowering scientists and researchers to drive progress in science and industry.

### Contact

Address: 3281 E Guasti Rd  
Ontario, CA 91761, United States  
Phone: (601) 213-4426  
Email: [info@benchchem.com](mailto:info@benchchem.com)

Contact our Ph.D. Support Team for a compatibility check