

The Development of Pyrazole-Containing Anticancer Agents: Application Notes and Protocols

Author: BenchChem Technical Support Team. **Date:** May 2026

Compound of Interest

Compound Name: 3-(1H-Pyrazol-5-yl)benzotrile

CAS No.: 149739-51-5

Cat. No.: B1599985

[Get Quote](#)

Introduction: The Prominence of the Pyrazole Scaffold in Oncology

The pyrazole ring, a five-membered heterocycle with two adjacent nitrogen atoms, has emerged as a "privileged scaffold" in medicinal chemistry. Its unique structural and electronic properties allow it to serve as an excellent pharmacophore, engaging in a variety of interactions with biological targets. In the realm of oncology, pyrazole derivatives have demonstrated remarkable versatility, leading to the development of numerous potent and selective anticancer agents.^{[1][2][3][4][5]} This has culminated in the FDA approval of several pyrazole-containing drugs, such as Crizotinib and Ruxolitinib, for the treatment of various malignancies.^{[6][7][8]}

These compounds exert their anticancer effects through diverse mechanisms of action, including the inhibition of protein kinases, interference with microtubule dynamics, and interaction with DNA.^{[1][2]} The synthetic tractability of the pyrazole core allows for extensive structure-activity relationship (SAR) studies, enabling the optimization of potency, selectivity, and pharmacokinetic profiles.^{[1][3][4]}

This guide provides a comprehensive overview of the development of pyrazole-containing anticancer agents, intended for researchers, scientists, and drug development professionals. It delves into their mechanisms of action, provides detailed protocols for their synthesis and biological evaluation, and offers insights into the causality behind experimental choices.

Mechanisms of Action: Targeting the Pillars of Cancer Progression

Pyrazole derivatives have been ingeniously designed to inhibit a wide array of molecular targets crucial for cancer cell proliferation, survival, and metastasis.[\[1\]\[2\]](#)

Protein Kinase Inhibition: A Dominant Strategy

The aberrant activity of protein kinases is a hallmark of many cancers, making them prime targets for therapeutic intervention.[\[6\]\[9\]](#) Pyrazole-based compounds have proven to be particularly effective as protein kinase inhibitors (PKIs).[\[6\]\[9\]](#)

- **Cyclin-Dependent Kinases (CDKs):** CDKs are key regulators of the cell cycle, and their dysregulation is a common feature of cancer.[\[10\]\[11\]](#) Pyrazole derivatives have been developed as potent inhibitors of CDKs, particularly CDK2 and the CDK4/6 complex, leading to cell cycle arrest and apoptosis.[\[10\]\[11\]\[12\]\[13\]](#) For instance, some novel pyrazole-thiazole hybrids have shown potential as dual CDK1 and CDK2 inhibitors.[\[13\]](#)
- **Janus Kinases (JAKs):** The JAK/STAT signaling pathway is crucial for cell growth and immunity, and its abnormal activation is implicated in various cancers.[\[14\]\[15\]\[16\]](#) Ruxolitinib, a pyrazole-containing drug, is a potent inhibitor of JAK1 and JAK2, approved for the treatment of myelofibrosis.[\[6\]\[15\]](#)
- **Receptor Tyrosine Kinases (RTKs):** This family of kinases, including EGFR and VEGFR, plays a pivotal role in tumor growth and angiogenesis. Pyrazole-based inhibitors have been designed to target these kinases, demonstrating significant anti-proliferative and anti-angiogenic effects.[\[1\]](#)
- **Other Kinases:** The versatility of the pyrazole scaffold has enabled the development of inhibitors for a broad range of other kinases, including AKT, BRAF, and BTK.[\[1\]\[6\]\[17\]\[18\]](#)

Below is a diagram illustrating the central role of protein kinases in cancer signaling and the points of intervention for pyrazole-based inhibitors.

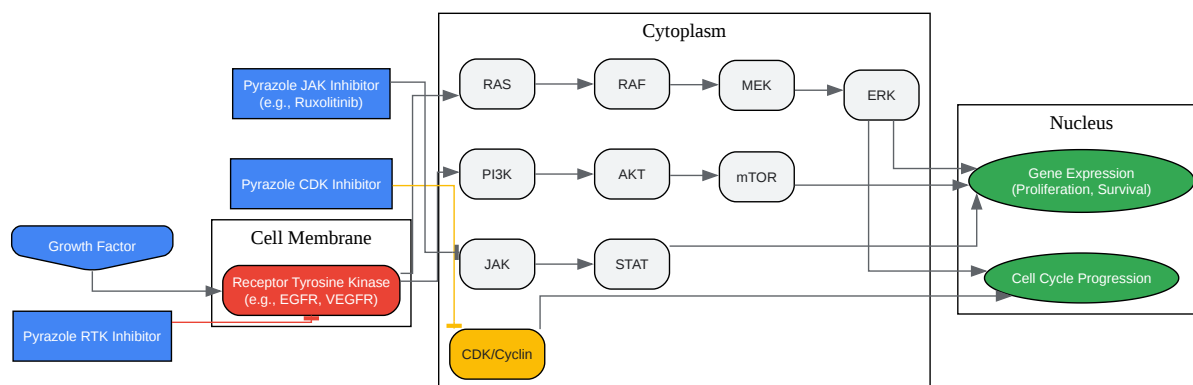

[Click to download full resolution via product page](#)

Caption: Pyrazole inhibitors targeting key oncogenic signaling pathways.

Tubulin Polymerization Inhibition

The microtubule network is essential for cell division, and its disruption is a validated anticancer strategy. Certain pyrazole derivatives act as tubulin polymerization inhibitors, leading to mitotic arrest and apoptosis.[1][7][19] These compounds often bind to the colchicine binding site on tubulin.[7]

DNA Intercalation and Damage

Some pyrazole-containing compounds have been shown to bind to the minor groove of DNA, inducing DNA damage and triggering apoptotic pathways.[1]

COX-2 Inhibition

Celecoxib, a well-known anti-inflammatory drug, is a selective COX-2 inhibitor with a pyrazole core.^{[20][21][22]} Overexpression of COX-2 has been linked to the development and progression of various cancers.^{[20][21]} Celecoxib exerts its anticancer effects through both COX-2 dependent and independent mechanisms, including the inhibition of angiogenesis and induction of apoptosis.^{[20][21][23][24]}

Synthesis of Pyrazole-Containing Anticancer Agents

The synthesis of pyrazole derivatives often involves the condensation of a 1,3-dicarbonyl compound or its equivalent with a hydrazine derivative. Modern synthetic methodologies, such as microwave-assisted and ultrasound-assisted synthesis, have been employed to improve reaction efficiency and yields.^[25]

Protocol: Microwave-Assisted Synthesis of a Generic Pyrazole Derivative

This protocol outlines a general procedure for the synthesis of a pyrazole derivative, which can be adapted for various substituted precursors.

Materials:

- Substituted 1,3-diketone (1.0 mmol)
- Substituted hydrazine hydrochloride (1.1 mmol)
- Ethanol (5 mL)
- Microwave reactor vials (10 mL)
- Magnetic stir bar
- Microwave synthesizer

Procedure:

- To a 10 mL microwave reactor vial containing a magnetic stir bar, add the substituted 1,3-diketone (1.0 mmol) and substituted hydrazine hydrochloride (1.1 mmol).

- Add ethanol (5 mL) to the vial and seal it with a cap.
- Place the vial in the microwave synthesizer.
- Irradiate the reaction mixture at a constant temperature of 100°C for 10-30 minutes. The reaction progress can be monitored by Thin Layer Chromatography (TLC).
- After completion of the reaction, allow the vial to cool to room temperature.
- The resulting mixture can be concentrated under reduced pressure.
- The crude product is then purified by column chromatography on silica gel using an appropriate eluent system (e.g., hexane/ethyl acetate) to afford the desired pyrazole derivative.
- Characterize the final product using spectroscopic techniques such as ^1H NMR, ^{13}C NMR, and mass spectrometry.[26]

Rationale for Microwave-Assisted Synthesis: Microwave irradiation can significantly accelerate the reaction rate by efficiently heating the polar solvent and reactants, leading to shorter reaction times and often cleaner product formation compared to conventional heating methods.
[25]

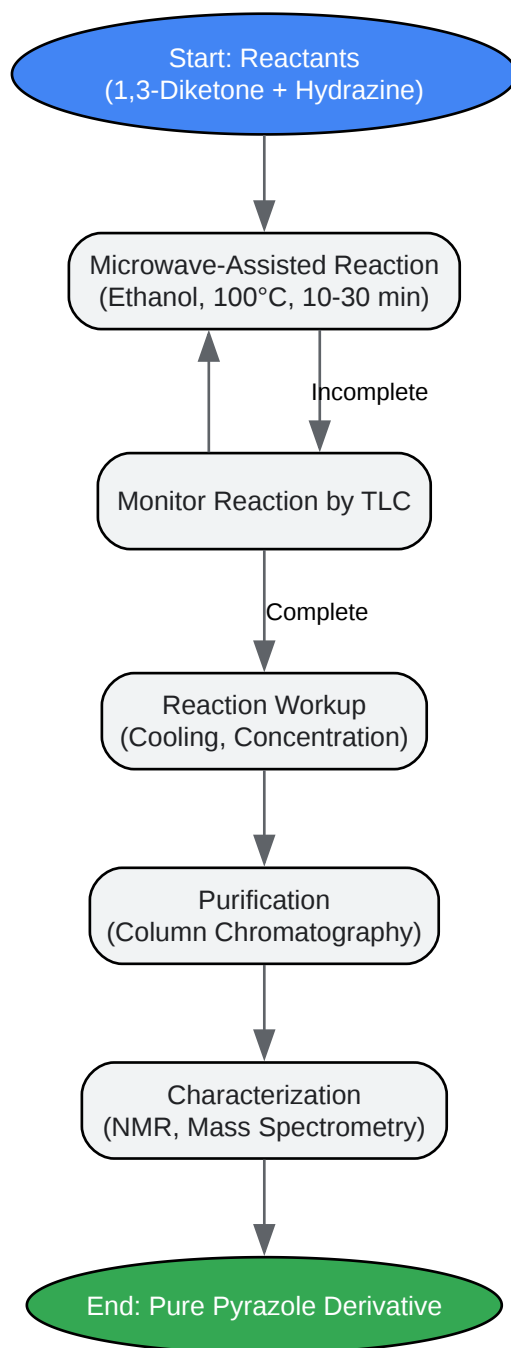

[Click to download full resolution via product page](#)

Need Custom Synthesis?

BenchChem offers custom synthesis for rare earth carbides and specific isotopic labeling.

Email: info@benchchem.com or [Request Quote Online](#).

Sources

- 1. Recent Advances in the Development of Pyrazole Derivatives as Anticancer Agents - PMC [[pmc.ncbi.nlm.nih.gov](https://pubmed.ncbi.nlm.nih.gov)]
- 2. Recent Advances in the Development of Pyrazole Derivatives as Anticancer Agents - PubMed [pubmed.ncbi.nlm.nih.gov]
- 3. A review of recent advances in anticancer activity and SAR of pyrazole derivatives - PubMed [pubmed.ncbi.nlm.nih.gov]
- 4. researchgate.net [researchgate.net]
- 5. Recent Advancement in Drug Design and Discovery of Pyrazole Biomolecules as Cancer and Inflammation Therapeutics - PMC [[pmc.ncbi.nlm.nih.gov](https://pubmed.ncbi.nlm.nih.gov)]
- 6. mdpi.com [mdpi.com]
- 7. Design, synthesis and in vitro cytotoxicity evaluation of indolo-pyrazoles grafted with thiazolidinone as tubulin polymerization inhibitors - PMC [[pmc.ncbi.nlm.nih.gov](https://pubmed.ncbi.nlm.nih.gov)]
- 8. Pyrazole-containing pharmaceuticals: target, pharmacological activity, and their SAR studies - PMC [[pmc.ncbi.nlm.nih.gov](https://pubmed.ncbi.nlm.nih.gov)]
- 9. Recent Advances in Pyrazole-based Protein Kinase Inhibitors as Emerging Therapeutic Targets - PubMed [pubmed.ncbi.nlm.nih.gov]
- 10. Advances in Pyrazole Based Scaffold as Cyclin-dependent Kinase 2 Inhibitors for the Treatment of Cancer - PubMed [pubmed.ncbi.nlm.nih.gov]
- 11. researchgate.net [researchgate.net]
- 12. Discovery of pyrazole-based analogs as CDK2 inhibitors with apoptotic-inducing activity: design, synthesis and molecular dynamics study - RSC Advances (RSC Publishing) [pubs.rsc.org]
- 13. tandfonline.com [tandfonline.com]
- 14. pubs.acs.org [pubs.acs.org]
- 15. Design, Synthesis, and Antitumor Evaluation of 4-Amino-(1H)-pyrazole Derivatives as JAKs Inhibitors - PMC [[pmc.ncbi.nlm.nih.gov](https://pubmed.ncbi.nlm.nih.gov)]
- 16. pubs.acs.org [pubs.acs.org]
- 17. Evaluation of Substituted Pyrazole-Based Kinase Inhibitors in One Decade (2011–2020): Current Status and Future Prospects - PMC [[pmc.ncbi.nlm.nih.gov](https://pubmed.ncbi.nlm.nih.gov)]
- 18. mdpi.com [mdpi.com]

- [19. ijpsjournal.com \[ijpsjournal.com\]](#)
- [20. mdpi.com \[mdpi.com\]](#)
- [21. Celecoxib in oncology: targeting the COX-2/PGE2 axis to reprogram the tumor immune microenvironment and enhance multimodal therapy - PMC \[pmc.ncbi.nlm.nih.gov\]](#)
- [22. news-medical.net \[news-medical.net\]](#)
- [23. sciencedaily.com \[sciencedaily.com\]](#)
- [24. The molecular mechanisms of celecoxib in tumor development - PMC \[pmc.ncbi.nlm.nih.gov\]](#)
- [25. Recent advances in the synthesis of anticancer pyrazole derivatives using microwave, ultrasound, and mechanochemical techniques - RSC Advances \(RSC Publishing\) \[pubs.rsc.org\]](#)
- [26. tandfonline.com \[tandfonline.com\]](#)
- To cite this document: BenchChem. [The Development of Pyrazole-Containing Anticancer Agents: Application Notes and Protocols]. BenchChem, [2026]. [Online PDF]. Available at: [<https://www.benchchem.com/product/b1599985/docs#the-development-of-pyrazole-containing-anticancer-agents-application-notes-and-protocols>]

Disclaimer & Data Validity:

The information provided in this document is for Research Use Only (RUO) and is strictly not intended for diagnostic or therapeutic procedures. While BenchChem strives to provide accurate protocols, we make no warranties, express or implied, regarding the fitness of this product for every specific experimental setup.

Technical Support: The protocols provided are for reference purposes. Unsure if this reagent suits your experiment?

Need Industrial/Bulk Grade? [Request Custom Synthesis Quote](#)

BenchChem

Our mission is to be the trusted global source of essential and advanced chemicals, empowering scientists and researchers to drive progress in science and industry.

Contact

Address: 3281 E Guasti Rd

Ontario, CA 91761, United States

Phone: (601) 213-4426

Email: info@benchchem.com

[Contact our Ph.D. Support Team for a compatibility check](#)