

Technical Support Center: Strategies for Preventing Epimerization During Piperidone Functionalization

Author: BenchChem Technical Support Team. **Date:** May 2026

Compound of Interest

Compound Name:	5-Methylpiperidin-2-one
CAS No.:	3298-16-6
Cat. No.:	B1599724

[Get Quote](#)

Welcome to the technical support center for piperidone chemistry. The piperidine ring is a cornerstone in medicinal chemistry, forming the structural core of countless pharmaceuticals.^[1] However, its functionalization is not without challenges, paramount among them being the unintended epimerization at stereocenters alpha to the carbonyl group. This guide is designed for researchers, scientists, and drug development professionals to diagnose, troubleshoot, and ultimately prevent the loss of stereochemical integrity during the chemical modification of piperidone scaffolds.

The Root of the Problem: Understanding α -Carbon Epimerization

Epimerization in piperidones is the undesirable inversion of a stereocenter. This process most commonly occurs at the α -carbon (the carbon atom adjacent to the carbonyl group). The underlying mechanism involves the formation of a planar enolate intermediate under either basic or acidic conditions. Once this achiral intermediate is formed, subsequent protonation or

reaction can occur from either face, leading to a mixture of diastereomers and eroding the enantiopurity of your material.[3]

The propensity for a piperidone to epimerize is dictated by a delicate balance of factors including the acidity of the α -proton, the stability of the resulting enolate, and the reaction conditions employed.

Visualizing the Mechanism of Epimerization

The following diagram illustrates the base-catalyzed epimerization pathway. The process begins with the abstraction of an α -proton to form a planar enolate, which is the key step where stereochemical information is lost.

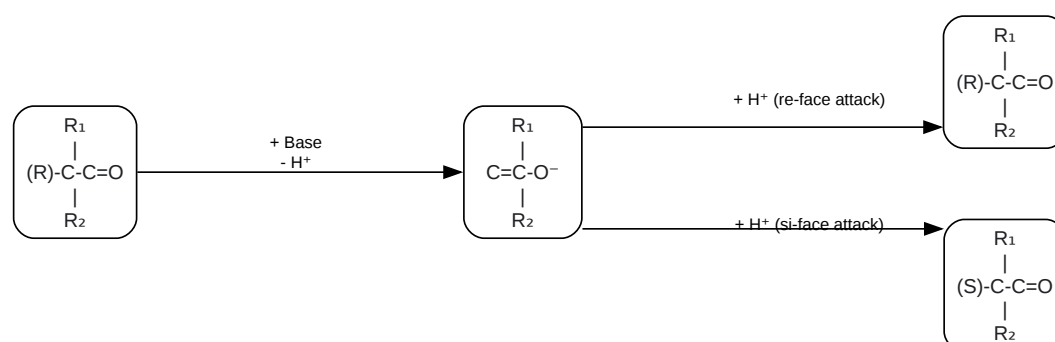

[Click to download full resolution via product page](#)

Caption: Base-catalyzed epimerization via a planar enolate intermediate.

Frequently Asked Questions (FAQs)

Here we address common questions encountered when working with piperidone functionalization.

Q1: Why is my piperidone epimerizing even with a mild base?

A1: The acidity of the α -proton is highly sensitive to the substituents on the piperidone ring. Electron-withdrawing groups, even those seemingly distant, can increase the acidity of the α -proton, making it susceptible to deprotonation by even weak bases. Furthermore, prolonged reaction times or elevated temperatures can shift the equilibrium towards the thermodynamically more stable epimer, even if the initial deprotonation is slow.

Q2: I'm performing an alkylation at the α -position. How can I avoid epimerization?

A2: This is a classic challenge balancing reactivity with stereocontrol. The key is to favor kinetic control over thermodynamic control.^{[3][4][5]} This means using conditions that promote rapid, irreversible alkylation of the desired enolate before equilibration can occur.

- Use a strong, bulky, non-nucleophilic base: Lithium diisopropylamide (LDA) or lithium hexamethyldisilazide (LHMDS) are excellent choices. They rapidly and quantitatively form the kinetic enolate.
- Low Temperatures are Critical: Perform the deprotonation and alkylation at low temperatures (typically $-78\text{ }^{\circ}\text{C}$). This slows down the rate of proton exchange and potential equilibration.^[4]
- Choice of Alkylating Agent: Use a reactive electrophile (e.g., methyl iodide, benzyl bromide) to ensure the alkylation step is fast.

Q3: Can the nitrogen protecting group influence epimerization?

A3: Absolutely. The N-protecting group has a significant impact on the conformation of the piperidine ring and the steric environment around the α -carbons.

- Bulky Protecting Groups: A large N-protecting group (e.g., Boc, Cbz) can influence the conformational equilibrium of the ring, potentially hindering the approach of a base to one of the α -protons, thus offering a degree of diastereoselectivity.^{[6][7]}
- Electron-Withdrawing Groups: N-acyl or N-sulfonyl groups can increase the acidity of the α -protons, making the system more prone to epimerization.

Q4: I suspect epimerization has occurred. How can I confirm and quantify it?

A4: Confirmation and quantification of the diastereomeric ratio are crucial.

- Chiral High-Performance Liquid Chromatography (HPLC): This is the gold standard for separating and quantifying stereoisomers.[8] Development of a robust chiral HPLC method is essential for monitoring the stereochemical purity of your material.[9][10][11][12]
- Nuclear Magnetic Resonance (NMR) Spectroscopy: In many cases, diastereomers will have distinct signals in the ^1H or ^{13}C NMR spectrum. Careful integration of these signals can provide a good estimate of the diastereomeric ratio. Nuclear Overhauser Effect (NOE) experiments can be invaluable for assigning the relative stereochemistry of the major and minor isomers.[13]

Troubleshooting Guide: When Stereochemistry Goes Wrong

This section provides a structured approach to troubleshooting when you detect epimerization in your reaction.

Observation	Potential Cause(s)	Recommended Solutions
Complete loss of stereochemistry (racemic or 1:1 diastereomeric mixture).	Reaction is under thermodynamic control. This can be due to: • Elevated temperature. • Prolonged reaction time. • Use of an equilibrating base (e.g., alkoxides).	Shift to Kinetic Control: • Lower the reaction temperature significantly (e.g., from room temperature to -78 °C).[4][14] • Reduce the reaction time. Quench the reaction as soon as the starting material is consumed. • Switch to a strong, non-nucleophilic base like LDA or KHMDS to ensure rapid and irreversible deprotonation.[3]
Partial epimerization (e.g., 80:20 mixture instead of >99:1).	<ul style="list-style-type: none">• Proton source present during enolate formation: The base may not be completely dry, or the solvent may contain protic impurities. • Slow addition of electrophile: If the electrophile is added too slowly, the enolate has time to equilibrate.• Temperature fluctuations: Inconsistent cooling can allow for brief periods of warming, promoting equilibration.	<ul style="list-style-type: none">• Ensure anhydrous conditions: Dry solvents and glassware rigorously. Use freshly titrated or newly purchased bases. • Add the electrophile rapidly to the cold enolate solution. • Maintain strict temperature control throughout the deprotonation and functionalization steps.
Epimerization observed during workup or purification.	<ul style="list-style-type: none">• Acidic or basic workup conditions: The product may be stable under the reaction conditions but epimerizes upon exposure to aqueous acid or base during workup. • Silica gel chromatography: The acidic nature of standard silica gel can catalyze epimerization of sensitive compounds.	<ul style="list-style-type: none">• Use a neutral quench: Quench the reaction with a saturated aqueous solution of NH₄Cl. • Buffer the aqueous layers during extraction if necessary. • Deactivate silica gel: Pre-treat silica gel with a base (e.g., triethylamine in the eluent) or use an alternative stationary phase like alumina.

Experimental Protocols: Best Practices in Action

Protocol 1: Kinetic Enolate Formation for α -Alkylation

This protocol is designed to minimize epimerization during the alkylation of a substituted piperidone.

Objective: To perform a diastereoselective alkylation of an N-Boc-protected piperidone.

Step-by-Step Methodology:

- Preparation: Under an inert atmosphere (Argon or Nitrogen), add a solution of the N-Boc-piperidone in anhydrous THF to a flame-dried flask.
- Cooling: Cool the solution to $-78\text{ }^{\circ}\text{C}$ using a dry ice/acetone bath.
- Deprotonation: Slowly add a solution of freshly prepared or titrated LDA (1.1 equivalents) dropwise to the cooled piperidone solution. Stir at $-78\text{ }^{\circ}\text{C}$ for 1 hour to ensure complete enolate formation.
- Alkylation: Rapidly add the alkylating agent (e.g., methyl iodide, 1.2 equivalents) to the enolate solution at $-78\text{ }^{\circ}\text{C}$.
- Reaction Monitoring: Monitor the reaction by TLC or LC-MS. The reaction is typically complete within 1-2 hours.
- Quenching: Quench the reaction at $-78\text{ }^{\circ}\text{C}$ by adding a saturated aqueous solution of NH_4Cl .
- Workup: Allow the mixture to warm to room temperature. Extract with an organic solvent (e.g., ethyl acetate), wash with brine, dry over anhydrous Na_2SO_4 , and concentrate in vacuo.
- Analysis: Determine the diastereomeric ratio of the crude product using chiral HPLC or ^1H NMR before purification.

Protocol 2: Chiral HPLC Method Development for Piperidone Enantiomers

Objective: To develop a method to resolve and quantify the enantiomers/diastereomers of a functionalized piperidone.

Step-by-Step Methodology:

- Column Screening: Begin by screening a set of chiral stationary phases (CSPs). Polysaccharide-based columns (e.g., Chiralcel OD-H, Chiralpak AD) are a good starting point for many piperidone systems.[\[12\]](#)
- Mobile Phase Screening:
 - Normal Phase: Start with a mobile phase of hexane/isopropanol. Vary the ratio (e.g., 90:10, 80:20) to optimize resolution.[\[12\]](#)
 - Additives: For basic piperidones, add a small amount of a basic modifier like diethylamine (0.1%) to the mobile phase to improve peak shape. For acidic compounds, use an acidic modifier like trifluoroacetic acid (0.1%).[\[12\]](#)
- Optimization: Once partial separation is achieved, optimize the mobile phase composition, flow rate, and column temperature to maximize resolution.
- Validation: Validate the final method for linearity, accuracy, and precision according to standard guidelines.[\[9\]](#)[\[10\]](#)

Visualizing the Workflow for Preventing Epimerization

This diagram outlines the decision-making process for a typical functionalization reaction where stereochemical integrity is paramount.

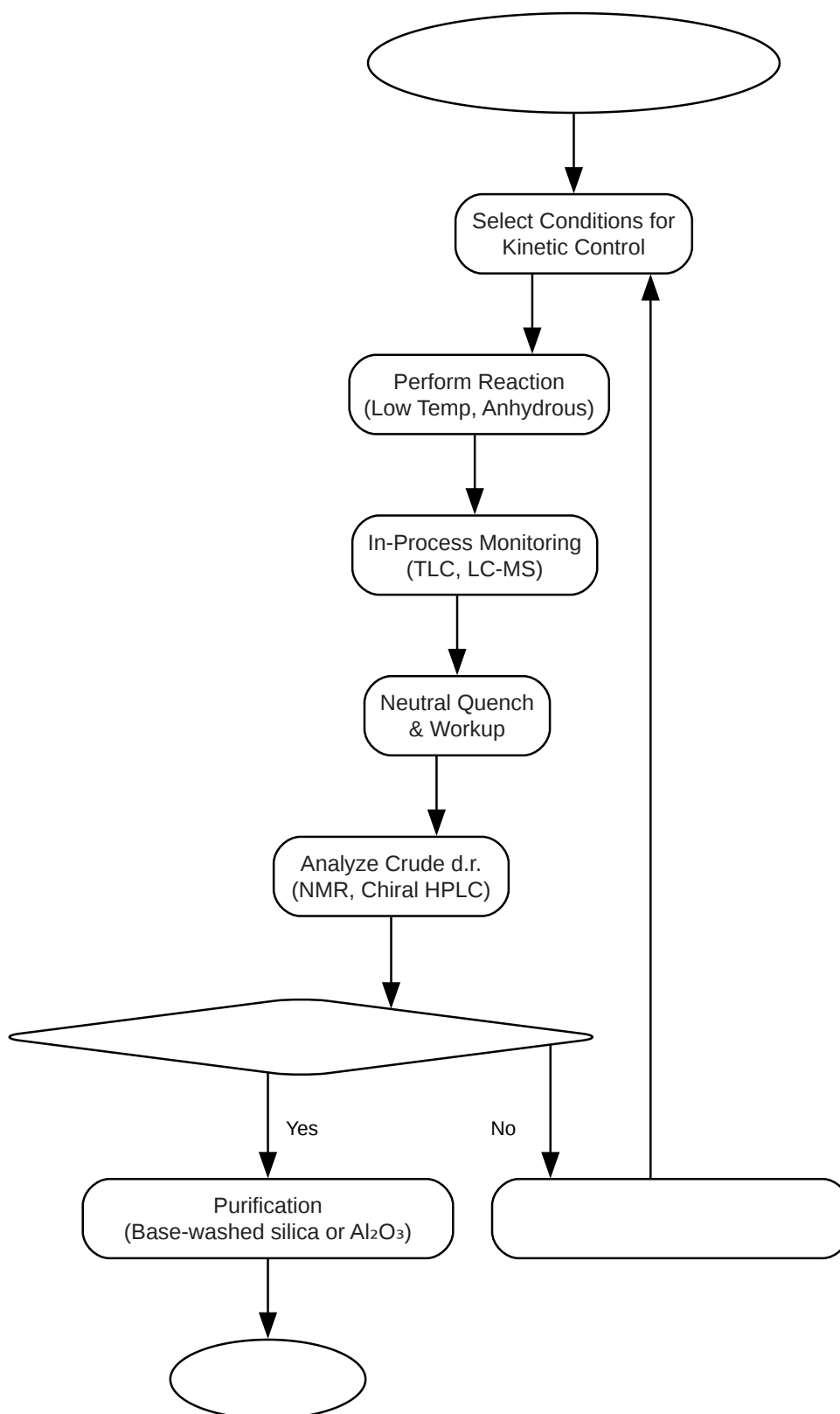

[Click to download full resolution via product page](#)

Caption: Decision workflow for stereoselective piperidone functionalization.

By understanding the mechanisms of epimerization and proactively implementing strategies to favor kinetic control, researchers can confidently functionalize piperidone scaffolds while preserving their critical stereochemical integrity.

References

- Asymmetric 'Clip-Cycle' synthesis of 3-spiropiperidines. Organic & Biomolecular Chemistry (RSC Publishing). Available from: [\[Link\]](#)
- Chiral auxiliary. Wikipedia. Available from: [\[Link\]](#)
- Chiral oxazolopiperidone lactams: versatile intermediates for the enantioselective synthesis of piperidine-containing natural products. PubMed. Available from: [\[Link\]](#)
- Recent advances in the synthesis of piperidones and piperidines. ScienceDirect. Available from: [\[Link\]](#)
- Aggregation, Racemization and Side Reactions in Peptide Synthesis. AAPTEC. Available from: [\[Link\]](#)
- Thermodynamic and kinetic reaction control. Wikipedia. Available from: [\[Link\]](#)
- Amino Acid-Protecting Groups. ResearchGate. Available from: [\[Link\]](#)
- Amino Acid-Protecting Groups. ACS Publications. Available from: [\[Link\]](#)
- Thermodynamic and Kinetic Products. Master Organic Chemistry. Available from: [\[Link\]](#)
- Epimerisation in Peptide Synthesis. MDPI. Available from: [\[Link\]](#)
- Piperidine Derivatives: Recent Advances in Synthesis and Pharmacological Applications. MDPI. Available from: [\[Link\]](#)
- Synthetic Approaches for Piperidone-Based Templates as Scaffolds to Access Chirally Enriched Donepezil Analogues. ACS Omega. Available from: [\[Link\]](#)
- Asymmetric Synthesis of trans-3-Alkoxyamino-4-Oxygenated-2-Piperidones Mediated by Transition-Metal-Free Dual C-H Oxidation and Its CAL-B-Assisted Enzymatic Resolution.

MDPI. Available from: [\[Link\]](#)

- Thermodynamic versus Kinetic Control. YouTube. Available from: [\[Link\]](#)
- Acid and base catalyzed piperidone synthesis from amino acid. ResearchGate. Available from: [\[Link\]](#)
- Kinetic Control Versus Thermodynamic Control Of A Reaction. Jack Westin. Available from: [\[Link\]](#)
- A validated RP-HPLC method for the determination of piperidone analogue of curcumin. PubMed. Available from: [\[Link\]](#)
- General Light-Mediated, Highly Diastereoselective Piperidine Epimerization: From Most Accessible to Most Stable Stereoisomer. PMC. Available from: [\[Link\]](#)
- Synthesis and bio-properties of 4-piperidone containing compounds as curcumin mimics. RSC Publishing. Available from: [\[Link\]](#)
- A Validated RP-HPLC Method for the Determination of Piperidone Analogue of Curcumin. ResearchGate. Available from: [\[Link\]](#)
- Analytical method for piperazine in an active pharmaceutical ingredient using chemical derivatization and HPLC-UV. Journal of Chemical and Pharmaceutical Research. Available from: [\[Link\]](#)
- A Strategy for Developing HPLC Methods for Chiral Drugs. LCGC International. Available from: [\[Link\]](#)
- piperidone analogs: synthesis and their diverse biological applications. ResearchGate. Available from: [\[Link\]](#)
- a) Different modalities of piperidine-containing drugs and drug candidates. ResearchGate. Available from: [\[Link\]](#)
- Piperidine-containing drugs and recently studied analogs - biological activity, mechanism of action and synthetic cascade access to their scaffolds. PubMed. Available from: [\[Link\]](#)

- Piperidine Synthesis. DTIC. Available from: [\[Link\]](#)
- Synthesis of Piperidones by MCR. ResearchGate. Available from: [\[Link\]](#)
- Synthesis method of chiral piperazinone derivative. Google Patents.
- Investigation of the role of stereoelectronic effects in the conformation of piperidones by NMR spectroscopy and X-ray diffraction. ResearchGate. Available from: [\[Link\]](#)
- Epimerisation in Peptide Synthesis. PMC. Available from: [\[Link\]](#)
- Synthesis and bio-properties of 4-piperidone containing compounds as curcumin mimics. RSC Publishing. Available from: [\[Link\]](#)
- Suppression of alpha-carbon racemization in peptide synthesis based on a thiol-labile amino protecting group. PMC. Available from: [\[Link\]](#)
- Chiral HPLC Separations. Phenomenex. Available from: [\[Link\]](#)
- Suppression of epimerization by cupric (II) salts in peptide synthesis using free amino acids as amino components. PubMed. Available from: [\[Link\]](#)
- Suppressing the epimerization of endo-thioamide peptides during Fmoc/t-Bu-based solid phase peptide synthesis. PubMed. Available from: [\[Link\]](#)
- Synthesis and Stability Studies of. Amanote Research. Available from: [\[Link\]](#)

Need Custom Synthesis?

BenchChem offers custom synthesis for rare earth carbides and specific isotopic labeling.

Email: info@benchchem.com or [Request Quote Online](#).

Sources

- [1. Piperidine Derivatives: Recent Advances in Synthesis and Pharmacological Applications - PMC \[pmc.ncbi.nlm.nih.gov\]](#)

- [2. Piperidine-containing drugs and recently studied analogs - biological activity, mechanism of action and synthetic cascade access to their scaffolds - PubMed \[pubmed.ncbi.nlm.nih.gov\]](#)
- [3. Thermodynamic and kinetic reaction control - Wikipedia \[en.wikipedia.org\]](#)
- [4. pdf.benchchem.com \[pdf.benchchem.com\]](#)
- [5. masterorganicchemistry.com \[masterorganicchemistry.com\]](#)
- [6. Protecting Groups in Peptide Synthesis: A Detailed Guide - Creative Peptides \[creative-peptides.com\]](#)
- [7. CN108129404B - Synthesis method of chiral piperazinone derivative - Google Patents \[patents.google.com\]](#)
- [8. phx.phenomenex.com \[phx.phenomenex.com\]](#)
- [9. A validated RP-HPLC method for the determination of piperidone analogue of curcumin - PubMed \[pubmed.ncbi.nlm.nih.gov\]](#)
- [10. researchgate.net \[researchgate.net\]](#)
- [11. jocpr.com \[jocpr.com\]](#)
- [12. chromatographyonline.com \[chromatographyonline.com\]](#)
- [13. pubs.acs.org \[pubs.acs.org\]](#)
- [14. youtube.com \[youtube.com\]](#)
- [To cite this document: BenchChem. \[Technical Support Center: Strategies for Preventing Epimerization During Piperidone Functionalization\]. BenchChem, \[2026\]. \[Online PDF\]. Available at: \[https://www.benchchem.com/product/b1599724/docs#technical-support-center-strategies-for-preventing-epimerization-during-piperidone-functionalization\]](#)

Disclaimer & Data Validity:

The information provided in this document is for Research Use Only (RUO) and is strictly not intended for diagnostic or therapeutic procedures. While BenchChem strives to provide accurate protocols, we make no warranties, express or implied, regarding the fitness of this product for every specific experimental setup.

Technical Support: The protocols provided are for reference purposes. Unsure if this reagent suits your experiment?

Need Industrial/Bulk Grade? [Request Custom Synthesis Quote](#)

BenchChem

Our mission is to be the trusted global source of essential and advanced chemicals, empowering scientists and researchers to drive progress in science and industry.

Contact

Address: 3281 E Guasti Rd
Ontario, CA 91761, United States
Phone: (601) 213-4426
Email: info@benchchem.com

[Contact our Ph.D. Support Team for a compatibility check](#)