

Technical Support Center: Optimization of 1,4-Benzodioxane Synthesis

Author: BenchChem Technical Support Team. **Date:** May 2026

Compound of Interest

Compound Name: *(R)*-(2,3-dihydrobenzo[b][1,4]dioxin-2-yl)methanamine
CAS No.: 46049-48-3
Cat. No.: B1599048

[Get Quote](#)

Welcome to the technical support center for the synthesis of 1,4-benzodioxane and its derivatives. This guide is designed for researchers, medicinal chemists, and drug development professionals who are working with this critical scaffold. The 1,4-benzodioxane moiety is a cornerstone in numerous biologically active compounds, from natural products to pharmaceuticals like Doxazosin.^[1] Its synthesis, while conceptually straightforward, is fraught with potential pitfalls that can impact yield, purity, and stereochemical outcomes.

This document moves beyond a simple recitation of steps. It is structured as a dynamic troubleshooting guide in a question-and-answer format to directly address the specific, practical challenges you may encounter in the lab. We will explore the causality behind each experimental parameter, empowering you to not only follow protocols but to intelligently optimize them.

Section 1: The Core Reaction - Mechanism and Standard Protocol

The most prevalent and reliable method for constructing the 1,4-benzodioxane ring is a variation of the Williamson ether synthesis. This involves the reaction of a catechol (or a substituted catechol) with a 1,2-dielectrophile, typically 1,2-dibromoethane or 1,2-dichloroethane, in the presence of a base.

Mechanistic Overview

The reaction proceeds via a double SN₂ mechanism. The base first deprotonates one of the phenolic hydroxyl groups of the catechol, forming a phenoxide. This nucleophilic phenoxide then attacks one of the electrophilic carbons of the 1,2-dihaloethane, displacing the first halide. This is followed by an intramolecular SN₂ reaction where the second phenolic hydroxyl is deprotonated and the resulting phenoxide attacks the remaining carbon, displacing the second halide to form the six-membered dioxane ring.

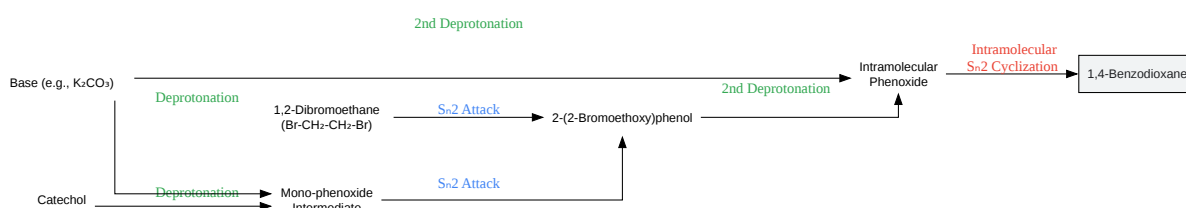

[Click to download full resolution via product page](#)

Caption: General mechanism for 1,4-benzodioxane synthesis.

Standard Experimental Protocol: Synthesis of Unsubstituted 1,4-Benzodioxane

This protocol provides a robust baseline for synthesis. All subsequent troubleshooting and optimization strategies will refer to this standard procedure.

Materials:

- Catechol (1.0 eq)
- 1,2-Dibromoethane (1.2 - 2.0 eq)
- Potassium Carbonate (K_2CO_3), anhydrous (2.5 eq)
- N,N-Dimethylformamide (DMF) or Acetone
- Ethyl Acetate (EtOAc)
- Brine (saturated NaCl solution)
- Anhydrous Magnesium Sulfate ($MgSO_4$)
- Silica Gel for column chromatography

Procedure:

- Setup: To a flame-dried round-bottom flask equipped with a magnetic stirrer and reflux condenser, add catechol (1.0 eq) and anhydrous potassium carbonate (2.5 eq).
- Solvent Addition: Add anhydrous DMF (or acetone) to create a stirrable slurry (approx. 0.5 M concentration with respect to catechol).
- Reagent Addition: Add 1,2-dibromoethane (1.5 eq) to the mixture.
- Reaction: Heat the reaction mixture to 60-80°C and stir vigorously for 12-24 hours.^[1] Monitor the reaction progress by Thin Layer Chromatography (TLC).
- Workup:
 - Cool the reaction to room temperature.
 - Dilute the mixture with ethyl acetate.
 - Wash with water (3x) to remove DMF and salts, followed by a brine wash (1x).^[1]
 - Dry the organic layer over anhydrous $MgSO_4$, filter, and concentrate under reduced pressure.

- Purification: Purify the crude residue by column chromatography on silica gel, typically using a gradient of ethyl acetate in hexanes to yield the pure 1,4-benzodioxane.[1]
- Characterization: Confirm the structure using $^1\text{H-NMR}$, $^{13}\text{C-NMR}$, and MS analysis.[1]

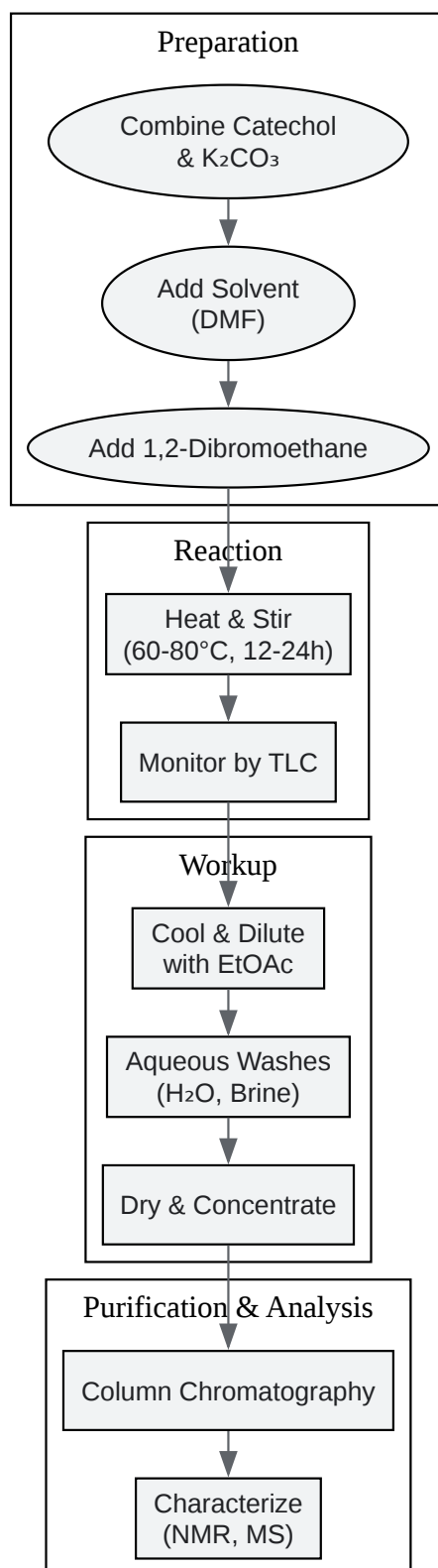

[Click to download full resolution via product page](#)

Caption: Standard experimental workflow for 1,4-benzodioxane synthesis.

Section 2: Troubleshooting Guide (Q&A Format)

This section addresses the most common failures and unexpected results.

Q1: My reaction yield is very low or I've recovered mostly starting material. What went wrong?

A1: This is a frequent issue stemming from several potential root causes:

- **Ineffective Base:** Potassium carbonate is hygroscopic. If it has absorbed moisture, it will be less effective at deprotonating the catechol. Always use freshly dried or anhydrous base. For sluggish reactions, a stronger base like cesium carbonate (Cs_2CO_3) can be more effective due to its higher solubility in organic solvents.
- **Wet Solvent:** Trace amounts of water in your reaction solvent (DMF, acetone) will protonate the phenoxide intermediate, quenching the nucleophile and halting the reaction. Ensure you are using anhydrous solvents.
- **Low Temperature:** While higher temperatures can promote side reactions, insufficient heat will result in a very slow or stalled reaction. A temperature range of 60-100°C is generally optimal.^[2]
- **Poor Reagent Quality:** Ensure your catechol has not oxidized (it should be a white to off-white solid) and that the 1,2-dibromoethane is not discolored.

Q2: My TLC shows multiple product spots, and my final yield after chromatography is still low. What are these side products?

A2: The formation of side products is a primary cause of yield loss. The most common culprits are:

- **Mono-alkylation Product:** The reaction stalls after the first $\text{S}_{\text{N}}2$ attack, leaving 2-(2-bromoethoxy)phenol as a major byproduct. This is often due to the issues described in A1 (poor base, water, low temp). The second, intramolecular cyclization is often the slower step.
- **Polymerization:** 1,2-dihaloethanes can self-polymerize or react with the phenoxide to form oligomeric ether chains, especially at excessively high temperatures (>120°C).^[2]

- Bis-catechol Ether: Two molecules of catechol can be linked by one molecule of the dihaloethane, forming a C₂-bridged dimer. Using a slight excess of the dihaloethane can help suppress this pathway.

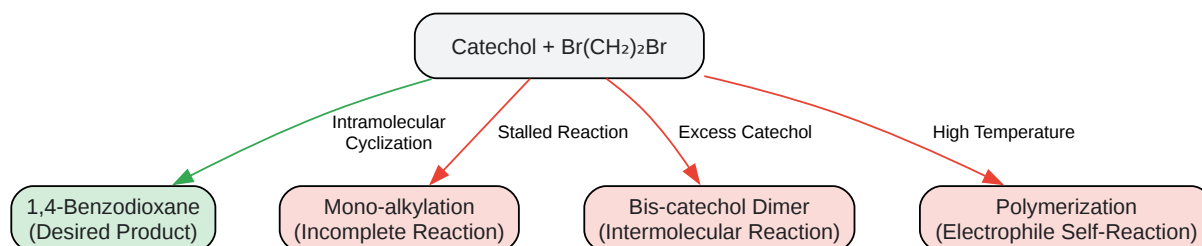

[Click to download full resolution via product page](#)

Caption: Common side reactions in 1,4-benzodioxane synthesis.

Q3: My product is a mixture of cis and trans isomers. How can I improve the stereoselectivity?

A3: For syntheses producing substituted benzodioxanes (e.g., from a substituted catechol and a chiral dielectrophile), controlling stereochemistry is critical.

- Thermodynamic vs. Kinetic Control: The trans isomer is generally the thermodynamically more stable product.[3] If you obtain a mixture of isomers, you may be able to isomerize the cis to the trans product by stirring the mixture with a base (like K₂CO₃ in DMF) after the initial reaction is complete.[3]
- Reaction Conditions: Acid-catalyzed cyclization steps, used in some alternative synthetic routes, are known to produce mixtures of cis and trans isomers.[3] Base-mediated Williamson synthesis tends to offer better control, often favoring the trans product.
- Choice of Synthetic Route: For high stereochemical fidelity, consider alternative routes like those employing chiral epoxides or palladium-catalyzed couplings, which can be designed to produce single enantiomers or diastereomers.[3]

Section 3: FAQs on Reaction Condition Optimization

This section provides answers to frequently asked questions about fine-tuning the reaction for optimal performance.

Q: Which combination of base and solvent is truly optimal?

A: The "best" combination depends on your specific substrate and scale, but here is a general guide:

Parameter	Options & Considerations	Causality & Rationale
Base	<p>K₂CO₃: Standard, inexpensive, effective. Cs₂CO₃: More expensive, but higher solubility and basicity can significantly accelerate slow reactions.</p> <p>NaH: Very strong base, but requires strictly anhydrous conditions and careful handling.</p>	<p>The base must be strong enough to deprotonate the phenol (pKa ~9-10). Increased solubility (Cs₂CO₃ > K₂CO₃) leads to a higher concentration of active phenoxide in solution, increasing the reaction rate.</p>
Solvent	<p>DMF: High boiling point, excellent at solvating salts. Can be difficult to remove during workup. Acetone: Lower boiling point, easier to remove. Less effective for poorly soluble reagents. Acetonitrile: Good alternative to DMF with easier removal.</p>	<p>The solvent must be polar aprotic to solvate the cation of the base and not interfere with the SN₂ reaction. A higher boiling point allows for higher reaction temperatures, increasing the rate according to the Arrhenius equation.</p>
Temperature	<p>Room Temp: Too slow for most combinations. 60-100°C: Optimal range for balancing reaction rate with minimal side product formation.^[2] >120°C: Risk of reagent decomposition and polymerization increases significantly.</p>	<p>Higher temperatures provide the necessary activation energy for the SN₂ reactions. However, excessive heat can also provide the activation energy for undesired pathways like elimination or polymerization.</p>
Catalyst	<p>Phase-Transfer Catalyst (PTC): e.g., Tetrabutylammonium bromide (TBAB).</p>	<p>A PTC is useful in less polar solvents or when reagent solubility is low. It works by transporting the phenoxide anion from the solid/aqueous phase into the organic phase where the electrophile resides, dramatically increasing the</p>

effective concentration of the nucleophile and accelerating the reaction.

Q: Can I use 1,2-dichloroethane instead of 1,2-dibromoethane?

A: Yes, but the reaction will be significantly slower. Bromine is a better leaving group than chlorine because the C-Br bond is weaker and the bromide ion is larger and more polarizable, making it more stable upon departure. To compensate for the lower reactivity of 1,2-dichloroethane, you will likely need to use higher temperatures, a stronger base (like Cs_2CO_3), and/or a longer reaction time.

Q: How critical is the stoichiometry of the reagents?

A: It is quite critical.

- Electrophile (1,2-dihaloethane): Using a slight excess (1.2-1.5 eq) helps ensure the catechol is fully consumed and minimizes the formation of the bis-catechol dimer side product. A large excess should be avoided as it can be difficult to remove and increases the risk of side reactions.
- Base: At least 2.0 equivalents of base are required to deprotonate both phenolic hydroxyl groups. An excess (e.g., 2.5 eq) is recommended to drive the equilibrium toward the phenoxide and neutralize any acidic impurities.

By understanding the interplay of these variables and anticipating common pitfalls, you can effectively troubleshoot and optimize your 1,4-benzodioxane synthesis, leading to higher yields, improved purity, and more reliable results in your research and development efforts.

References

- Idris, N., Anderson, A. and Bakare, O. (2022) Synthesis and Characterization of 1,4-Benzodioxane-6-Carboxylic Acid Amide Analogs. *International Journal of Organic Chemistry*, 12, 143-160. [[Link](#)]
- Pilkington, L. I., & Barker, D. (2015). Synthesis and biology of 1,4-benzodioxane lignan natural products. *Natural Product Reports*, 32(9), 1369–1391. [[Link](#)]

- Celentano, A., et al. (2021). 1,4-Benzodioxane, an evergreen, versatile scaffold in medicinal chemistry: a review of its recent applications in drug design. AIR Unimi. [[Link](#)]
- Google Patents. (1996).
- Singh, O. (2008). Chemistry and pharmacology of benzodioxanes. Organic Chemistry: An Indian Journal, 4(2). [[Link](#)]
- Di Sarno, V., et al. (2024). 2S-(1RS-benzyloxy-hex-5-enyl)-2,3-dihydro-1,4-benzodioxine: Synthesis and Assignment of Configuration. Molecules, 29(9), 2002. [[Link](#)]
- PrepChem. (2022). Preparation of 1,4-benzodioxane. [[Link](#)]
- Cacciari, B., et al. (2007). Structure–Activity Relationships in 1,4-Benzodioxan-Related Compounds. 9.(1) From 1,4-Benzodioxane to 1,4-Dioxane Ring as a Promising Template of Novel α 1D-Adrenoreceptor Antagonists, 5-HT1A Full Agonists, and Cytotoxic Agents. Journal of Medicinal Chemistry, 50(17), 4218–4229. [[Link](#)]

Need Custom Synthesis?

BenchChem offers custom synthesis for rare earth carbides and specific isotopic labeling.

Email: info@benchchem.com or [Request Quote Online](#).

Sources

1. Synthesis and Characterization of 1,4-Benzodioxane-6-Carboxylic Acid Amide Analogs [scirp.org]
2. CA2215604C - Process for preparation of 1,4-benzodioxane derivative - Google Patents [patents.google.com]
3. Synthesis and biology of 1,4-benzodioxane lignan natural products - Natural Product Reports (RSC Publishing) DOI:10.1039/C5NP00048C [pubs.rsc.org]
- To cite this document: BenchChem. [Technical Support Center: Optimization of 1,4-Benzodioxane Synthesis]. BenchChem, [2026]. [Online PDF]. Available at: [<https://www.benchchem.com/product/b1599048/docs#technical-support-center-optimization-of-1-4-benzodioxane-synthesis>]

Disclaimer & Data Validity:

The information provided in this document is for Research Use Only (RUO) and is strictly not intended for diagnostic or therapeutic procedures. While BenchChem strives to provide accurate protocols, we make no warranties, express or implied, regarding the fitness of this product for every specific experimental setup.

Technical Support: The protocols provided are for reference purposes. Unsure if this reagent suits your experiment?

Need Industrial/Bulk Grade? [Request Custom Synthesis Quote](#)

BenchChem

Our mission is to be the trusted global source of essential and advanced chemicals, empowering scientists and researchers to drive progress in science and industry.

Contact

Address: 3281 E Guasti Rd
Ontario, CA 91761, United States
Phone: (601) 213-4426
Email: info@benchchem.com

[Contact our Ph.D. Support Team for a compatibility check](#)