

Solid-phase peptide synthesis with fluorinated prolines.

Author: BenchChem Technical Support Team. **Date:** May 2026

Compound of Interest

Compound Name: *Boc-alpha-(4-fluorobenzyl)-DL-proline*

CAS No.: 351002-78-3

Cat. No.: B1599101

[Get Quote](#)

Application Note: Precision Engineering of Peptide Conformation using Solid-Phase Synthesis with Fluorinated Prolines

Abstract & Introduction

The incorporation of fluorinated proline analogs into peptides is a powerful strategy for modulating conformational stability, proteolytic resistance, and membrane permeability. Unlike standard amino acid substitutions that primarily alter sterics or charge, fluorination of the proline pyrrolidine ring exploits the stereoelectronic gauche effect. This quantum mechanical phenomenon allows researchers to pre-organize peptide backbone geometry, locking amide bonds into specific cis or trans conformations.

This guide provides a comprehensive protocol for the Solid-Phase Peptide Synthesis (SPPS) of peptides containing (4R)-4-fluoroproline, (4S)-4-fluoroproline, and 4,4-difluoroproline. It addresses the specific synthetic challenges posed by the electron-withdrawing nature of fluorine and provides a mechanistic framework for analog selection.

Mechanistic Foundation: The Fluorine Gauche Effect

To successfully deploy fluorinated prolines, one must understand the causality between ring puckering and amide bond geometry. The high electronegativity of fluorine induces a polarization of the C–F bond, which prefers to align antiperiplanar to the adjacent C–H bond (the gauche effect).

- (4R)-4-fluoroproline (Flp): The fluorine atom forces the ring into a -exo pucker.^[1] This conformation optimizes the interaction between the prolyl nitrogen lone pair and the preceding carbonyl carbon, strongly stabilizing the trans peptide bond (characteristic of the collagen triple helix and Polyproline II helices).
- (4S)-4-fluoroproline (flp): The fluorine atom forces the ring into a -endo pucker.^{[2][3]} This destabilizes the interaction, shifting the equilibrium toward the cis peptide bond (useful for -turns or folding initiation sites).

Visualizing the Stereoelectronic Logic

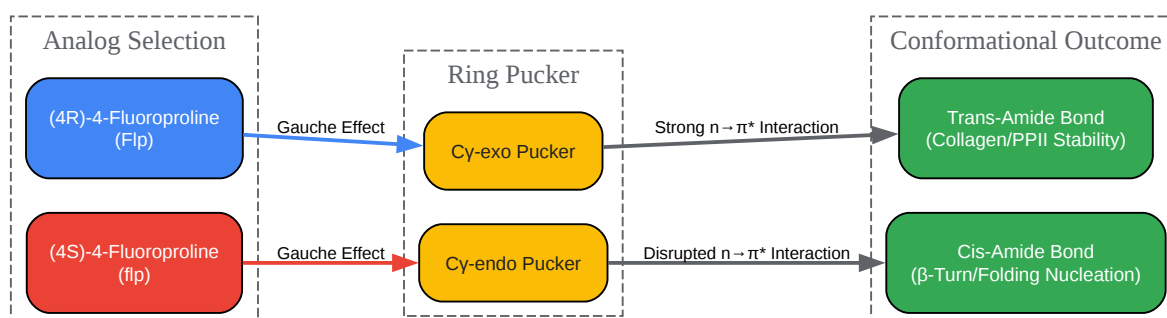

[Click to download full resolution via product page](#)

Figure 1: Causal pathway linking fluorine stereochemistry to peptide backbone geometry.

Strategic Selection of Analogs

Use the following table to select the correct analog for your specific biological application.

Analog	Stereochemistry	Ring Pucker		Primary Application
(4R)-F-Pro	(2S, 4R)	-exo	High (~6.7)	Stabilizing collagen triple helices; increasing metabolic stability; locking Polyproline II helices.
(4S)-F-Pro	(2S, 4S)	-endo	Low (~2.5)	Inducing -turns; destabilizing helices; probing folding kinetics (accelerates cis-trans isomerization).
4,4-difluoro-Pro	Achiral at C4	Mixed	Moderate	Increasing hydrophobicity; preventing enzymatic degradation without strong conformational bias.

Protocol: Automated SPPS of Fluorinated Peptides

Pre-requisites:

- Scale: 0.1 mmol
- Resin: Rink Amide ChemMatrix (0.45 mmol/g) or 2-CTC (for C-terminal acids). Note: Low loading resins are preferred to prevent aggregation.
- Reagents: Fmoc-(4R)-F-Pro-OH, Fmoc-(4S)-F-Pro-OH.

Step-by-Step Workflow

- Resin Swelling:
 - Swell resin in DCM for 20 minutes, then wash with DMF (min).
- Fmoc Deprotection:
 - Treat with 20% Piperidine in DMF (min, min).
 - Critical: Fluorinated prolines are secondary amines. The deprotection of the preceding amino acid exposes the N-terminus of the fluoroproline. Ensure thorough washing (DMF min) to remove piperidine, as secondary amines are prone to side reactions with residual base.
- Coupling of Fluorinated Proline (The "Difficult" Step):
 - The electron-withdrawing fluorine reduces the nucleophilicity of the proline nitrogen (during subsequent couplings) and can sterically hinder the incoming activation complex.
 - Reagent Cocktail: 4 eq. Fmoc-AA-OH, 4 eq. HATU, 8 eq. DIPEA in DMF.[\[4\]](#)
 - Condition: Microwave irradiation is highly recommended.

- Standard: 75°C for 5 minutes.
- Sensitive (Cys/His): 50°C for 10 minutes.
- Alternative (Room Temp): If microwave is unavailable, use DIC/OxymaPure (4 eq each) for 60–120 minutes. Double coupling is mandatory for room temp protocols.
- Coupling the Next Amino Acid (onto the F-Pro N-terminus):
 - This is the rate-limiting step. The secondary amine of F-Pro is less nucleophilic than native Pro.
 - Action: Use HATU/HOAt activation. PyBOP is often insufficient.
 - Protocol: Double couple the subsequent amino acid (2 45 min).
- Cleavage & Isolation:
 - Cocktail: 95% TFA, 2.5% TIS, 2.5% .
 - Time: 2–3 hours at room temperature.
 - Note: The C–F bond is chemically stable to standard TFA cleavage conditions.

Visual Workflow for Critical Steps

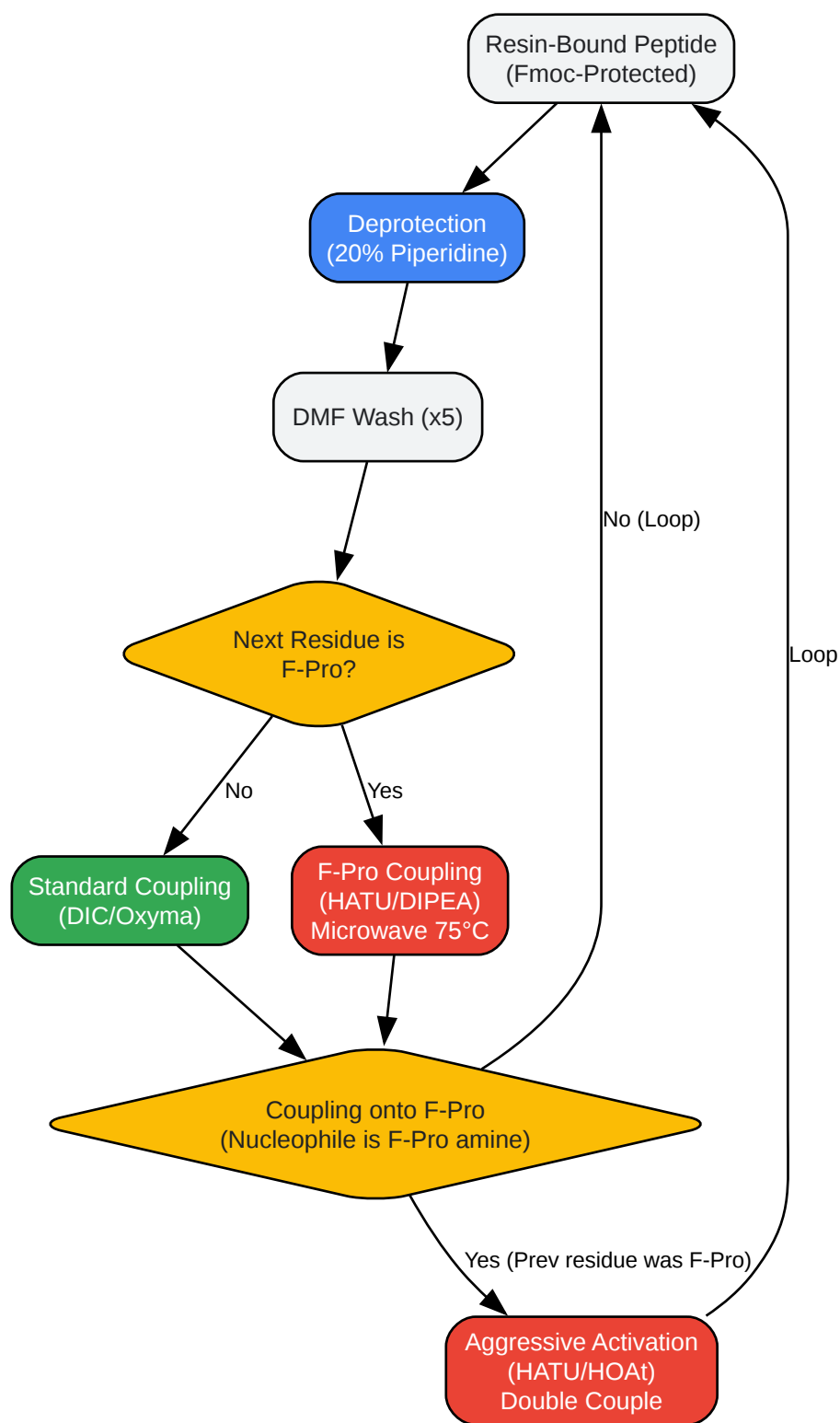

[Click to download full resolution via product page](#)

Figure 2: Decision tree for coupling logic, highlighting the need for aggressive activation when coupling onto the fluorinated secondary amine.

Troubleshooting & Quality Control

Common Failure Modes

- Incomplete Coupling onto F-Pro:
 - Symptom:[\[2\]](#)[\[3\]](#)[\[4\]](#)[\[5\]](#)[\[6\]](#)[\[7\]](#) Deletion sequences in Mass Spec ().
 - Fix: Switch to COMU or HATU at 75°C. Perform a chloranil test (sensitive for secondary amines) to verify coupling completion; the standard Kaiser test is ineffective for prolines.
- Racemization:
 - Symptom:[\[2\]](#)[\[3\]](#)[\[4\]](#)[\[6\]](#)[\[7\]](#) Split peaks in HPLC.
 - Cause: Over-activation of the Fmoc-F-Pro-OH carboxyl group during coupling.
 - Fix: Use OxymaPure as an additive to suppress racemization if using DIC. Avoid pre-activation times >2 minutes.

Characterization

- F NMR: This is the gold standard for verifying incorporation and conformation.
 - (4R)-F-Pro: Typically appears around -176 ppm (in).
 - (4S)-F-Pro: Distinct chemical shift differences allow quantification of diastereomeric purity.
- Circular Dichroism (CD): Use CD to verify the induction of PPII helicity. (4R)-F-Pro peptides should show a hyper-intense positive band at 225 nm compared to native proline.

References

- Hodges, J. A., & Raines, R. T. (2003). Stereoelectronic Effects on Collagen Stability: The Dichotomy of 4-Fluoroproline Diastereomers. *Journal of the American Chemical Society*, 125(31), 9262–9263. [Link](#)

- Newberry, R. W., & Raines, R. T. (2016). 4-Fluoroprolines: Conformational Analysis and Effects on the Stability and Folding of Peptides and Proteins. *Topics in Heterocyclic Chemistry*, 48, 1–25. [Link](#)
- Holmgren, S. K., et al. (1998). Code for Collagen's Stability Deciphered. *Nature*, 392, 666-667. [Link](#)
- Vergara-Irigaray, N., et al. (2015). Are double couplings in SPPS interesting for purity of short peptides? *ResearchGate Discussion/Protocol Review*. [Link](#)
- Pedersen, S. L., et al. (2012).[8] Microwave heating in solid-phase peptide synthesis. *Chemical Society Reviews*, 41, 1826-1844. [Link](#)

Need Custom Synthesis?

BenchChem offers custom synthesis for rare earth carbides and specific isotopic labeling.

Email: info@benchchem.com or [Request Quote Online](#).

Sources

- 1. raineslab.com [raineslab.com]
- 2. raineslab.com [raineslab.com]
- 3. bif.wisc.edu [bif.wisc.edu]
- 4. chemistry.du.ac.in [chemistry.du.ac.in]
- 5. Stereoelectronic effects on polyproline conformation - PMC [pmc.ncbi.nlm.nih.gov]
- 6. bif.wisc.edu [bif.wisc.edu]
- 7. US6040422A - Synthesis and use of amino acid fluorides as peptide coupling reagent - Google Patents [patents.google.com]
- 8. Advances in Fmoc solid-phase peptide synthesis - PMC [pmc.ncbi.nlm.nih.gov]
- To cite this document: BenchChem. [Solid-phase peptide synthesis with fluorinated prolines.]. BenchChem, [2026]. [Online PDF]. Available at: [<https://www.benchchem.com/product/b1599101/docs#solid-phase-peptide-synthesis-with-fluorinated-prolines>]

Disclaimer & Data Validity:

The information provided in this document is for Research Use Only (RUO) and is strictly not intended for diagnostic or therapeutic procedures. While BenchChem strives to provide accurate protocols, we make no warranties, express or implied, regarding the fitness of this product for every specific experimental setup.

Technical Support: The protocols provided are for reference purposes. Unsure if this reagent suits your experiment?

Need Industrial/Bulk Grade? [Request Custom Synthesis Quote](#)

BenchChem

Our mission is to be the trusted global source of essential and advanced chemicals, empowering scientists and researchers to drive progress in science and industry.

Contact

Address: 3281 E Guasti Rd
Ontario, CA 91761, United States
Phone: (601) 213-4426
Email: info@benchchem.com

[Contact our Ph.D. Support Team for a compatibility check](#)