

Comparative study of fluorinated vs non-fluorinated proline analogues.

Author: BenchChem Technical Support Team. **Date:** May 2026

Compound of Interest

Compound Name: *Boc-alpha-(4-fluorobenzyl)-DL-proline*

CAS No.: 351002-78-3

Cat. No.: B1599101

[Get Quote](#)

Comparative Guide: Fluorinated vs. Non-Fluorinated Proline Analogues

Executive Summary

Proline is unique among proteinogenic amino acids due to its cyclic pyrrolidine side chain, which restricts the backbone

dihedral angle and allows for a populated equilibrium between cis and trans peptide bond isomers.[1] The incorporation of fluorine into the proline ring—specifically at the 4-position—is not merely a steric substitution; it is a stereoelectronic edit that fundamentally alters the conformational landscape of the molecule.

This guide compares native Proline with its fluorinated analogues (4R-Fluoroproline, 4S-Fluoroproline, and 4,4-Difluoroproline). It details how the high electronegativity of fluorine (

) exploits the gauche effect to lock ring puckering, thereby dictating the cis/trans ratio of the peptide backbone. These tools are essential for stabilizing secondary structures (e.g., collagen

triple helices), designing protease-resistant peptides, and utilizing

F-NMR as a background-free structural probe.

Mechanistic Foundation: The Stereoelectronic "Switch"

The primary differentiator between fluorinated and non-fluorinated proline is the gauche effect. In the absence of fluorine, the pyrrolidine ring of proline rapidly fluctuates between two envelope conformations: C

-endo (down) and C

-exo (up).

When fluorine is introduced, the C–F bond prefers to align antiperiplanar to the C–H (or N–C) bond to maximize

orbital overlap. This locks the ring pucker, which in turn dictates the backbone amide preference via

interactions between the amide oxygen and the ester/amide carbonyl.

Diagram 1: Stereoelectronic Control of Proline Conformation

This diagram illustrates the causal link between Fluorine stereochemistry, Ring Pucker, and Peptide Bond geometry.

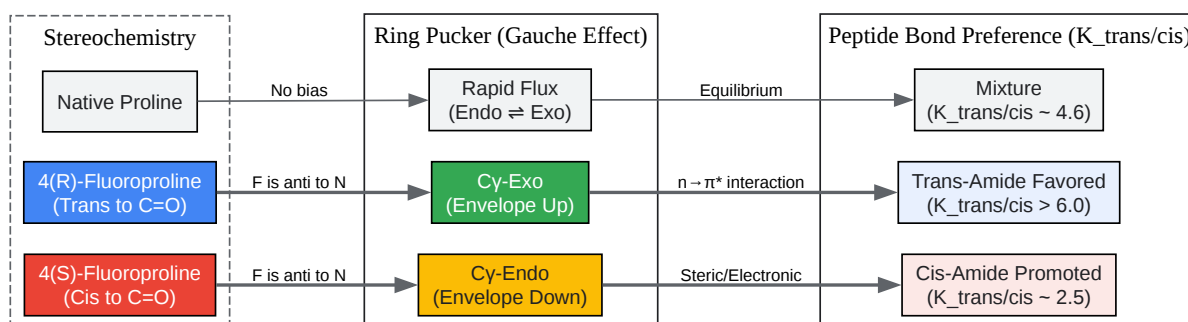

[Click to download full resolution via product page](#)

Caption: The stereochemistry of the fluorine substituent (4R vs 4S) dictates the ring pucker via the gauche effect, which subsequently biases the cis/trans equilibrium of the peptide backbone.

Comparative Analysis: Physicochemical & Conformational Properties[2][3][4]

The following table synthesizes experimental data comparing native Proline with its fluorinated counterparts. Note the divergent effects of the 4R and 4S diastereomers.

Table 1: Comparative Properties of Proline Analogues

Feature	L-Proline (Pro)	(4R)- Fluoroproline (Flp)	(4S)- Fluoroproline (flp)	4,4- Difluoroproline (Dfp)
Fluorine Orientation	N/A	Trans to Carbonyl	Cis to Carbonyl	Geminal
Preferred Pucker	Flux (Endo Exo)	C -Exo (Strong bias)	C -Endo (Strong bias)	C -Exo (Slight bias)
(Water)*	~4.6	6.7 (Stabilizes Trans)	2.5 (Promotes Cis)	~5.0
Collagen Stability	Standard (ref)	Hyperstable (in Yaa pos.)	Destabilizing (in Yaa pos.)	Moderate Stability
Amine pKa	10.6	9.2	9.3	8.6
Lipophilicity	Low	Moderate	Moderate	High
Primary Utility	General Structure	Stabilizing -helices / PPII	Promoting -turns / cis-bonds	Metabolic Stability / Hydrophobicity

*Values based on model peptide Ac-Pro-OMe in water.

Applications in Drug Discovery & Protein Engineering[5]

Collagen Hyperstability (The "Yaa" Position Rule)

Collagen triple helices consist of Xaa-Yaa-Gly repeats.[2][3][4] The Yaa position requires a C-exo pucker to fit the triple helix geometry.[3][4]

- Native: 4-Hydroxyproline (Hyp) is naturally used at Yaa.

- Fluorinated: Replacing Hyp with (4R)-Flp at the Yaa position significantly increases thermal stability () because fluorine is more electronegative than oxygen, enforcing the exo pucker more strictly via the gauche effect.
- Caution: Using (4S)-flp at the Yaa position destroys the triple helix structure. Conversely, (4S)-flp is stabilizing at the Xaa position (which prefers endo).[4]

F-NMR as a Conformational Reporter

Because

F has 100% natural abundance and zero background in biological systems, these analogues act as sensitive probes.

- Chemical Shift Sensitivity: The cis and trans isomers of fluoroproline typically show distinct F chemical shifts (ppm), allowing direct quantification of populations without complex isotopic labeling.
- Dynamics: Relaxation measurements () of the fluorine nucleus reveal local backbone dynamics on the nanosecond-to-millisecond timescale.

Metabolic Stability

Fluorination at the 4-position blocks metabolic oxidation by prolyl hydroxylases. Furthermore, the inductive effect lowers the pKa of the N-terminal amine, reducing susceptibility to oxidative deamination.

Experimental Protocol: Determining via F-NMR

This protocol describes how to synthesize a model peptide and determine the conformational equilibrium constant using NMR. This is a self-validating method: if the integration does not sum to 100% or peaks are broadened beyond recognition, the peptide purity or aggregation state is suspect.

Diagram 2: Experimental Workflow

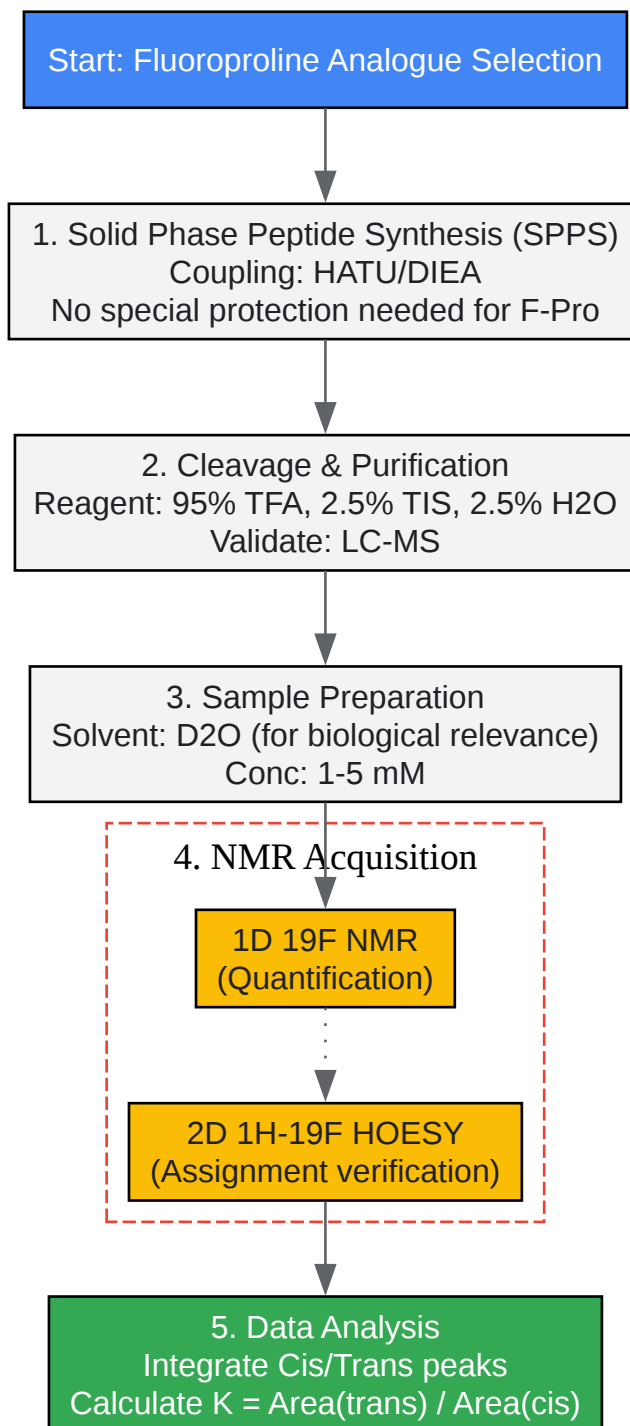

[Click to download full resolution via product page](#)

Caption: Workflow for synthesizing fluorinated peptides and quantifying cis/trans isomerism using ¹⁹F-NMR.

Detailed Steps:

- Peptide Synthesis:
 - Use standard Fmoc-SPPS protocols. Fluoroprolines (Fmoc-4-fluoro-L-proline) are commercially available and stable under standard coupling (HATU/DIEA) and deprotection (Piperidine) conditions.
 - Critical Check: Ensure no racemization occurs during coupling; use collidine instead of DIEA if coupling to a cysteine.
- NMR Sample Prep:
 - Dissolve lyophilized peptide in D₂O (phosphate buffer pH 7.4 is recommended to standardize pKa effects).
 - Add an internal standard (e.g., Trifluoroacetic acid or Fluorobenzene) in a coaxial insert if absolute chemical shift referencing is required, though relative integration does not require it.
- Data Acquisition:
 - 1D

F NMR: Acquire with sufficient scans (NS > 64) and a relaxation delay () at least (typically 5-10 seconds for fluorine) to ensure quantitative accuracy.
 - Peak Assignment: The trans isomer is generally the major species. The cis isomer will appear upfield or downfield depending on the specific sequence context, but typically separated by >0.5 ppm.
- Calculation:
 - Integrate the distinct fluorine peaks.

References

- Raines, R. T. (2003).[2] Stereoelectronic Effects on Collagen Stability: The Dichotomy of 4-Fluoroproline Diastereomers. *Journal of the American Chemical Society*. [Link](#)
- O'Hagan, D. (2008). Understanding organofluorine chemistry. An introduction to the C–F bond. *Chemical Society Reviews*. [Link](#)
- Verhoorck, S. J., et al. (2018).[5] Fluorinated Prolines as Conformational Tools and Reporters for Peptide and Protein Chemistry. *Biochemistry*. [Link](#)
- Shoulders, M. D., & Raines, R. T. (2009). Collagen structure and stability.[1][6][2] *Annual Review of Biochemistry*. [Link](#)
- Newberry, R. W., & Raines, R. T. (2016). The $n \rightarrow \pi$ Interaction*. *Accounts of Chemical Research*. [Link](#)

Need Custom Synthesis?

BenchChem offers custom synthesis for rare earth carbides and specific isotopic labeling.

Email: info@benchchem.com or [Request Quote Online](#).

Sources

- 1. 4-Fluoroprolines: Conformational Analysis and Effects on the Stability and Folding of Peptides and Proteins - PMC [pmc.ncbi.nlm.nih.gov]
- 2. Stereoelectronic effects on collagen stability: the dichotomy of 4-fluoroproline diastereomers - PubMed [pubmed.ncbi.nlm.nih.gov]
- 3. Origin of the Stability Conferred upon Collagen by Fluorination - PMC [pmc.ncbi.nlm.nih.gov]
- 4. bif.wisc.edu [bif.wisc.edu]
- 5. researchgate.net [researchgate.net]
- 6. pubs.acs.org [pubs.acs.org]
- To cite this document: BenchChem. [Comparative study of fluorinated vs non-fluorinated proline analogues.]. BenchChem, [2026]. [Online PDF]. Available at:

[\[https://www.benchchem.com/product/b1599101/docs#comparative-study-of-fluorinated-vs-non-fluorinated-proline-analogues\]](https://www.benchchem.com/product/b1599101/docs#comparative-study-of-fluorinated-vs-non-fluorinated-proline-analogues)

Disclaimer & Data Validity:

The information provided in this document is for Research Use Only (RUO) and is strictly not intended for diagnostic or therapeutic procedures. While BenchChem strives to provide accurate protocols, we make no warranties, express or implied, regarding the fitness of this product for every specific experimental setup.

Technical Support: The protocols provided are for reference purposes. Unsure if this reagent suits your experiment?

Need Industrial/Bulk Grade? [Request Custom Synthesis Quote](#)

BenchChem

Our mission is to be the trusted global source of essential and advanced chemicals, empowering scientists and researchers to drive progress in science and industry.

Contact

Address: 3281 E Guasti Rd
Ontario, CA 91761, United States
Phone: (601) 213-4426
Email: info@benchchem.com

[Contact our Ph.D. Support Team for a compatibility check](#)