

Application Note: Dibenzofuran Architectures in Organic Electronics

Author: BenchChem Technical Support Team. **Date:** May 2026

Compound of Interest

Compound Name: 4-Phenyldibenzofuran

CAS No.: 74104-10-2

Cat. No.: B1599384

[Get Quote](#)

Executive Summary

Dibenzofuran (DBF) derivatives have emerged as a critical scaffold in the "molecular engineering" of organic electronics. Unlike their sulfur analogs (dibenzothiophenes), DBF derivatives possess a smaller atomic radius (Oxygen vs. Sulfur) and higher electronegativity. This results in higher Triplet Energy (

> 2.9 eV), making them ideal host materials for blue phosphorescent and Thermally Activated Delayed Fluorescence (TADF) emitters.^[1] Furthermore, their rigid planar structure facilitates dense packing in the solid state, enhancing charge carrier mobility for OFET applications.

This guide details the protocol for synthesizing high-

DBF hosts, fabricating vacuum-deposited OLED devices, and validating their optoelectronic performance.

Material Design Strategy

Why Dibenzofuran?

- High Triplet Energy (

): The DBF core typically exhibits

values around 3.0 eV. This is critical for preventing reverse energy transfer from blue emitters (which require high-

hosts) back to the host, a common loss mechanism.

- **Bipolar Transport Potential:** While the DBF core is naturally p-type (hole-transporting), it can be coupled with electron-deficient moieties (e.g., benzophenone, phosphine oxide, or triazine) to create bipolar host materials. This balances charge injection and widens the recombination zone, reducing efficiency roll-off.
- **Thermal Stability:** The fused ring system offers high glass transition temperatures (C), ensuring morphological stability during device operation.[2]

Target Molecule Architecture

For this protocol, we focus on a representative high-performance architecture: Carbazole-Dibenzofuran Hybrids (e.g., CzDBF).

- **Donor (Hole Transport):** Carbazole.
- **Core (High ngcontent-ng-c176312016="" _ngghost-ng-c3009799073="" class="inline ng-star-inserted"> / Stability):** Dibenzofuran.
- **Linkage:** C-N coupling (e.g., at the 2- or 4-position of DBF) to tune steric hindrance and conjugation length.

Protocol A: Synthesis of DBF-Carbazole Host

Objective: Synthesize 4-(9H-carbazol-9-yl)dibenzo[b,d]furan (4-CzDBF) via Buchwald-Hartwig amination.

Reagents & Equipment[4][5]

- **Reactants:** 4-iododibenzo[b,d]furan (1.0 eq), 9H-carbazole (1.2 eq).

- Catalyst: Tris(dibenzylideneacetone)dipalladium(0) [] (2 mol%).
- Ligand: Tri-tert-butylphosphine [] (4 mol%).
- Base: Sodium tert-butoxide () (1.5 eq).
- Solvent: Anhydrous Toluene (degassed).
- Atmosphere: Argon or Nitrogen glovebox/Schlenk line.

Step-by-Step Procedure

- Pre-Activation: In a glovebox, mix and in a small volume of toluene. Stir for 10 minutes to generate the active catalytic species.
- Reaction Assembly: In a Schlenk flask, combine 4-iododibenzo[b,d]furan, carbazole, and .
- Addition: Add the catalyst solution and remaining toluene to the flask.
- Reflux: Seal the flask, remove from the glovebox (if applicable), and connect to a reflux condenser under inert gas flow. Heat to 110°C for 12–24 hours.
- Quenching: Cool to room temperature. Filter the mixture through a Celite pad to remove inorganic salts and palladium black. Wash with dichloromethane.
- Purification (Critical):
 - Concentrate the filtrate under reduced pressure.
 - Perform column chromatography (Silica gel; Hexane/Toluene gradient).

- Sublimation: For OLED grade purity (>99.9%), the solid must undergo thermal gradient sublimation at high vacuum (Torr).

Synthesis Workflow Diagram

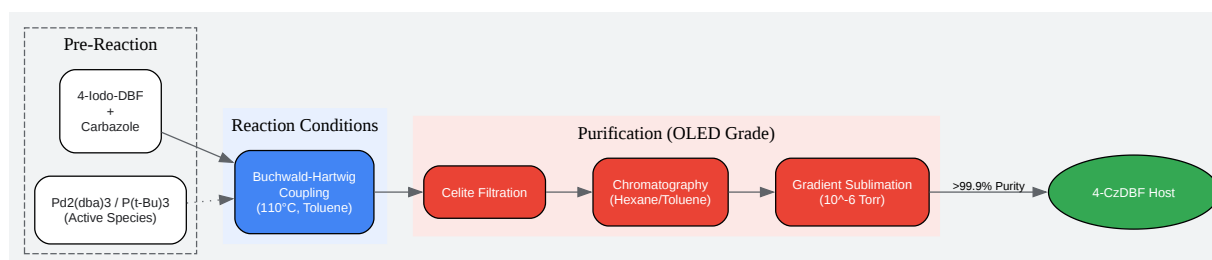

[Click to download full resolution via product page](#)

Figure 1: Synthetic workflow for high-purity Dibenzofuran-Carbazole host materials.

Protocol B: Device Fabrication (Vacuum Deposition)

Objective: Fabricate a blue phosphorescent OLED using the synthesized DBF derivative as the host.

Device Architecture

Structure: ITO / HAT-CN (10 nm) / TAPC (40 nm) / EML (30 nm) / TmPyPB (40 nm) / LiF (1 nm) / Al (100 nm)

- Anode: Indium Tin Oxide (ITO).
- HIL: HAT-CN (Hole Injection Layer).
- HTL: TAPC (Hole Transport Layer).

- EML (Emissive Layer): DBF-Host doped with 10-20% Blue Emitter (e.g., Flrpic or TADF dopant).
- ETL: TmPyPB (Electron Transport Layer).
- Cathode: LiF/Al.

Fabrication Steps

- Substrate Cleaning:
 - Sonicate patterned ITO glass in: Deionized water
Acetone
Isopropanol (15 min each).
 - UV-Ozone Treatment: Expose substrates to UV-Ozone for 15 minutes immediately before loading into the vacuum chamber. This increases the work function of ITO for better hole injection.
- Vacuum Loading:
 - Transfer substrates to the vacuum thermal evaporator.
 - Pump down to base pressure
Torr.
- Deposition (Organic Layers):
 - Rate Control: Maintain evaporation rate at 0.5–1.0 Å/s for organic layers.
 - Co-Deposition (EML): Use dual-source evaporation for the Host (DBF) and Dopant. Calibrate rates to achieve the desired doping ratio (e.g., Host: 0.9 Å/s, Dopant: 0.1 Å/s for 10% doping).
- Deposition (Cathode):

- Deposit LiF at a very slow rate (0.1 Å/s).
- Deposit Aluminum at 2.0–5.0 Å/s.
- Encapsulation:
 - Transfer to glovebox (ppm) without air exposure.
 - Encapsulate with UV-curable epoxy and a glass cover slip.

Characterization & Validation

Key Parameters Table

The following table summarizes expected properties for high-performance DBF derivatives compared to standard references.

Parameter	Symbol	Method	Target Value (DBF Host)	Relevance
Triplet Energy		Low-Temp PL (77 K)	> 2.90 eV	Essential to confine triplet excitons on blue emitters.[1]
HOMO Level		Cyclic Voltammetry	-6.0 to -5.8 eV	Matches deep HOMO of blue emitters for hole injection.
LUMO Level		Cyclic Voltammetry	-2.4 to -2.1 eV	Affects electron injection barrier from ETL.
Glass Transition		DSC	> 110°C	Prevents crystallization during operation (Device Lifetime).
Decomposition		TGA (5% loss)	> 400°C	Ensures stability during vacuum sublimation.

Protocol: Triplet Energy () Determination[1][2][6]

- Dissolve the DBF derivative in 2-methyltetrahydrofuran or toluene (M).
- Place the sample in a quartz tube and immerse in liquid nitrogen (77 K).
- Excite the sample using a spectrofluorometer (excitation wavelength ~ absorption max).
- Record the phosphorescence spectrum (using a delay time, e.g., 1-10 ms, to gate out fluorescence).

- Calculation:

, where

is the highest energy vibrational peak of the phosphorescence spectrum.

Device Logic Diagram

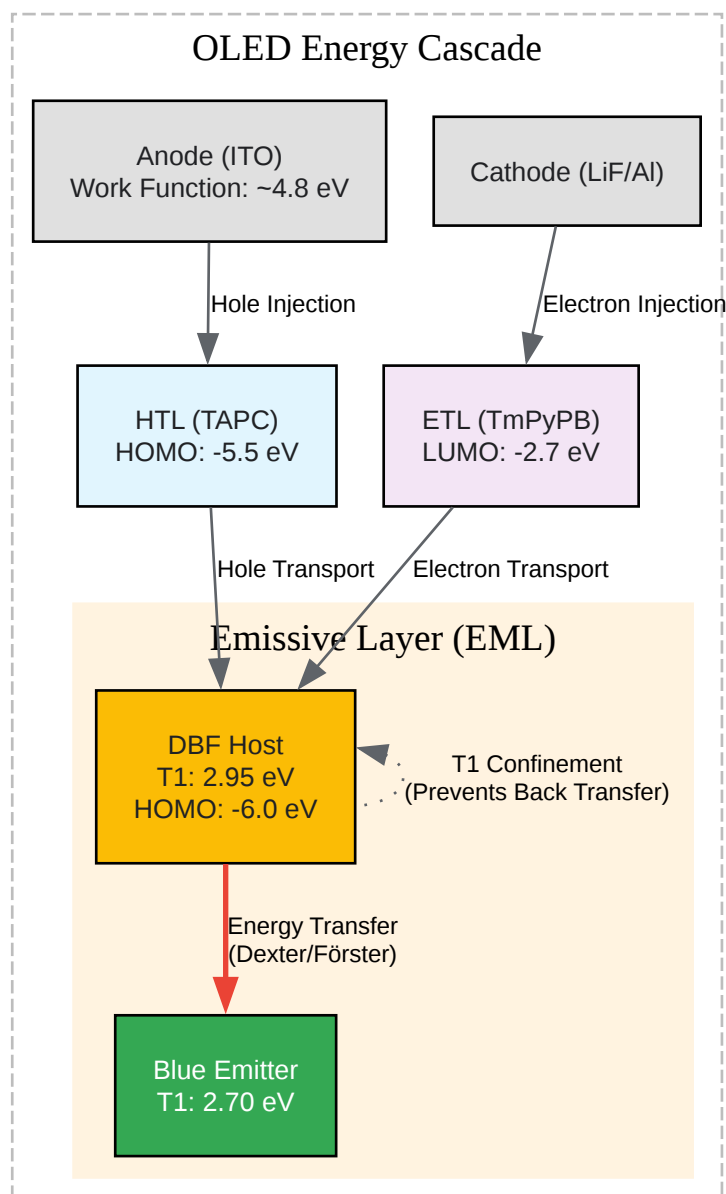

[Click to download full resolution via product page](#)

Figure 2: Energy level diagram illustrating the role of the DBF host in confining triplet energy within the emitter.

Troubleshooting & Optimization

- Issue: Low Efficiency (Roll-off).
 - Cause: Charge imbalance in the EML.
 - Solution: DBF is hole-dominant. Co-host with an electron-transporting material (e.g., Triazine derivative) or modify the DBF scaffold with electron-withdrawing groups (e.g., Cyano-DBF) to create a bipolar host.
- Issue: Short Device Lifetime.
 - Cause: Crystallization of the organic layer or exciton-polaron annihilation.
 - Solution: Ensure the synthesized DBF derivative has a
 - C. Verify purity by HPLC before sublimation. Impurities (halogens) act as deep traps and quenching sites.
- Issue: Voltage Rise.
 - Cause: Large injection barrier.
 - Solution: Check the HOMO level alignment. If the DBF HOMO is too deep (-6.1 eV), use an intermediate HTL with a HOMO around -5.8 eV to step the holes in.

References

- The Role of Dibenzofuran Derivatives in Modern OLED Technology. Vertex AI Search Result 1.1. [Link](#)
- Dibenzofuran Host Application for Blue Thermally Activated Delayed Fluorescence (TADF) OLEDs. Open Readings. [Link](#)

- Regioisomer Effects of Dibenzofuran-based Bipolar Host Materials on Yellow Phosphorescent OLED Device Performance. ResearchGate. [Link](#)
- Visible-Light-Promoted Synthesis of Dibenzofuran Derivatives. Journal of Organic Chemistry. [Link](#)
- Step-by-Step Guide for Harnessing Organic Light Emitting Diodes by Solution Processed Device Fabrication. PubMed. [Link](#)
- Effects of Substitution Position of Carbazole-Dibenzofuran Based High Triplet Energy Hosts. MDPI. [Link](#)
- Syntheses of dibenzo[d,d']benzo[2,1-b:3,4-b']difuran derivatives and their application to organic field-effect transistors. Beilstein Journals. [Link](#)
- Fabrication of a Solution-Processed White Light Emitting Diode. MDPI. [Link](#)

Need Custom Synthesis?

BenchChem offers custom synthesis for rare earth carbides and specific isotopic labeling.

Email: info@benchchem.com or [Request Quote Online](#).

Sources

- 1. openreadings.eu [openreadings.eu]
- 2. mdpi.com [mdpi.com]
- To cite this document: BenchChem. [Application Note: Dibenzofuran Architectures in Organic Electronics]. BenchChem, [2026]. [Online PDF]. Available at: [<https://www.benchchem.com/product/b1599384/docs#application-note-dibenzofuran-architectures-in-organic-electronics>]

Disclaimer & Data Validity:

The information provided in this document is for Research Use Only (RUO) and is strictly not intended for diagnostic or therapeutic procedures. While BenchChem strives to provide

accurate protocols, we make no warranties, express or implied, regarding the fitness of this product for every specific experimental setup.

Technical Support: The protocols provided are for reference purposes. Unsure if this reagent suits your experiment?

Need Industrial/Bulk Grade? [Request Custom Synthesis Quote](#)

BenchChem

Our mission is to be the trusted global source of essential and advanced chemicals, empowering scientists and researchers to drive progress in science and industry.

Contact

Address: 3281 E Guasti Rd

Ontario, CA 91761, United States

Phone: (601) 213-4426

Email: info@benchchem.com

[Contact our Ph.D. Support Team for a compatibility check](#)