

# Technical Support Center: Synthesis of Pyrazole Amines

**Author:** BenchChem Technical Support Team. **Date:** May 2026

## Compound of Interest

Compound Name: *3-(5-methyl-1H-pyrazol-4-yl)propan-1-amine*

CAS No.: 28739-42-6

Cat. No.: B1598101

[Get Quote](#)

Welcome to the Technical Support Center for the synthesis of pyrazole amines. This guide is designed for researchers, scientists, and professionals in drug development who are navigating the complexities of pyrazole amine synthesis. Here, we move beyond simple protocols to provide in-depth, field-tested insights into the causality behind experimental choices, helping you troubleshoot common issues and prevent side reactions. Our aim is to equip you with the knowledge to create a self-validating system for your experiments, ensuring both accuracy and efficiency.

## Troubleshooting Guide: Navigating Common Side Reactions

This section addresses specific problems you might encounter during the synthesis of pyrazole amines. Each issue is presented in a question-and-answer format, providing not just a solution, but a mechanistic understanding of the problem.

## Issue 1: Poor Regioselectivity - "I'm getting a mixture of two pyrazole isomers. How can I control which one is formed?"

Q: My reaction with an unsymmetrical 1,3-dicarbonyl compound and a substituted hydrazine is giving me a mixture of regioisomers. How can I improve the selectivity for my desired product?

A: This is one of the most common challenges in pyrazole synthesis, particularly in the Knorr synthesis and related methods. The formation of two regioisomers arises from the two non-equivalent carbonyl groups of the 1,3-dicarbonyl compound, both of which can undergo initial condensation with the hydrazine.<sup>[1]</sup> The regiochemical outcome is a delicate balance of steric and electronic factors of your substrates, as well as the reaction conditions.

Underlying Causality:

The reaction proceeds through the formation of a hydrazone intermediate.<sup>[2]</sup> With a substituted hydrazine (e.g., methylhydrazine), the initial attack can occur from either the substituted or unsubstituted nitrogen. Generally, the less sterically hindered and more nucleophilic nitrogen will react preferentially. Subsequently, intramolecular cyclization occurs onto the second carbonyl group.

- **Steric Hindrance:** A bulky substituent on the hydrazine or the dicarbonyl compound will direct the reaction pathway to minimize steric clash.
- **Electronic Effects:** The electrophilicity of the two carbonyl carbons plays a crucial role. A more electrophilic carbonyl will react faster with the hydrazine. For instance, in 4,4,4-trifluoro-1-arylbutan-1,3-diones, the carbonyl adjacent to the trifluoromethyl group is more electrophilic, which can lead to preferential attack at that position.<sup>[1]</sup>
- **pH of the Reaction Medium:** The pH can influence which nitrogen of the hydrazine is more nucleophilic and the rate of dehydration steps. Acid catalysis is often employed in the Knorr synthesis to facilitate the dehydration steps.<sup>[1][2]</sup>

Troubleshooting Protocol & Mitigation Strategies:

- **Solvent Selection:** The choice of solvent can dramatically influence regioselectivity. The use of fluorinated alcohols like 2,2,2-trifluoroethanol (TFE) or 1,1,1,3,3,3-hexafluoro-2-propanol (HFIP) has been shown to significantly improve regioselectivity compared to standard solvents like ethanol.<sup>[3]</sup> This is attributed to the ability of these solvents to form hydrogen bonds, which can modulate the reactivity of the intermediates.
- **Control of Reaction Temperature:** Lowering the reaction temperature can often enhance selectivity by favoring the kinetically controlled product.
- **Choice of Hydrazine Salt:** Using the hydrochloride salt of the hydrazine in an aprotic dipolar solvent can sometimes afford better regioselectivity.<sup>[1]</sup>
- **Protecting Groups:** In some cases, a strategy involving protecting groups on the 1,3-dicarbonyl can be employed to ensure that only one carbonyl group is available for the initial reaction.

#### Data-Driven Insights: Solvent Effects on Regioselectivity

Solvent	Typical Regioisomeric Ratio (Product A:Product B)	Reference
Ethanol	Often close to 1:1, highly substrate-dependent	[1][3]
TFE	Can significantly favor one isomer (e.g., up to 98:2)	[3]
HFIP	Often provides the highest selectivity (e.g., >99:1)	[3]

#### Visualizing the Competing Pathways:

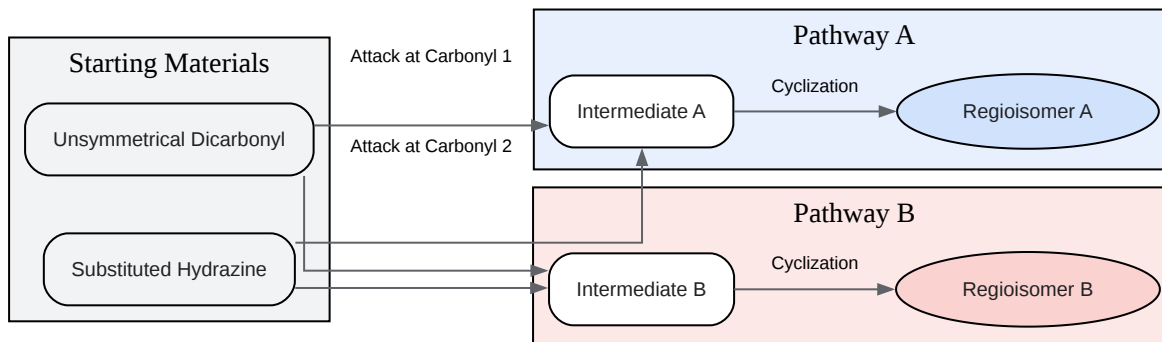

[Click to download full resolution via product page](#)

Caption: Competing pathways in pyrazole synthesis.

## Issue 2: Incomplete Reaction or Formation of Pyrazoline Intermediate - "My reaction has stalled, and I'm isolating a non-aromatic product."

Q: My reaction to form a pyrazole seems to have stopped, and the product I've isolated doesn't appear to be aromatic by NMR. What's going on?

A: It is highly likely that you have isolated a pyrazoline intermediate. The final step in many pyrazole syntheses is an oxidation or elimination to form the aromatic pyrazole ring.<sup>[1]</sup> If this step is not efficient under your reaction conditions, the pyrazoline will be the major product.

Underlying Causality:

The cyclization of the hydrazine with the 1,3-dicarbonyl or an  $\alpha,\beta$ -unsaturated carbonyl compound initially forms a non-aromatic five-membered ring, a pyrazoline.<sup>[1]</sup> This intermediate must then undergo a formal oxidation (loss of two hydrogen atoms) or elimination of a leaving group to achieve the stable aromatic pyrazole system.

Troubleshooting Protocol & Mitigation Strategies:

- In-situ Oxidation: You can often drive the reaction to completion by adding an oxidizing agent directly to the reaction mixture.
  - Mild Oxidation: Simply heating the reaction mixture in DMSO under an oxygen atmosphere can be effective.[4]
  - Chemical Oxidants: Common oxidizing agents include bromine, iodine, or copper salts.[1][4]
- Stepwise Oxidation: If in-situ oxidation is not clean, you can isolate the pyrazoline and then subject it to a separate oxidation step. This can sometimes provide a cleaner product.
- Choice of Starting Materials: If you start with an  $\alpha,\beta$ -unsaturated ketone that has a good leaving group at the  $\beta$ -position, the elimination to the pyrazole can occur spontaneously after the initial cyclization.[1]

#### Experimental Protocol: Oxidation of a Pyrazoline to a Pyrazole

- Dissolve the crude pyrazoline in a suitable solvent (e.g., DMSO, acetic acid, or an alcohol).
- Add the oxidizing agent (e.g., 1.1 equivalents of  $I_2$ ) portion-wise at room temperature.
- Monitor the reaction by TLC. The pyrazole product should have a different  $R_f$  value and may be more UV-active than the pyrazoline.
- Work-up the reaction by quenching any excess oxidant (e.g., with aqueous sodium thiosulfate for iodine) and then proceed with a standard aqueous work-up and extraction.
- Purify the crude pyrazole by column chromatography or recrystallization.

#### Visualizing the Final Aromatization Step:



[Click to download full resolution via product page](#)

Caption: Aromatization of pyrazoline to pyrazole.

## Frequently Asked Questions (FAQs)

Q1: What are the best practices for purifying pyrazole amines?

A1: Purification can often be challenging due to the similar polarities of starting materials, products, and byproducts.

- **Column Chromatography:** This is the most common method. A gradient elution from a non-polar solvent (e.g., hexanes) to a more polar solvent (e.g., ethyl acetate) is typically effective.
- **Acid-Base Extraction:** If your pyrazole amine has a basic amino group and other impurities are neutral or acidic, you can perform an acid-base extraction. Dissolve the crude mixture in an organic solvent, extract with dilute acid (e.g., 1M HCl), wash the aqueous layer with an organic solvent to remove neutral impurities, then basify the aqueous layer and extract your product back into an organic solvent.
- **Recrystallization:** If your product is a solid, recrystallization can be a highly effective method for obtaining very pure material.

Q2: How can I use TLC to monitor my pyrazole synthesis reaction?

A2: Thin-layer chromatography (TLC) is an indispensable tool.

- **Spotting:** Spot the starting materials, a co-spot (starting material and reaction mixture), and the reaction mixture on the TLC plate.
- **Eluent:** A mixture of hexanes and ethyl acetate is a good starting point for the mobile phase.
- **Visualization:** Pyrazoles are often UV-active, so they can be visualized under a UV lamp.<sup>[5]</sup> Staining with iodine or potassium permanganate can also be effective for visualizing compounds that are not UV-active.<sup>[5]</sup>

Q3: Can over-alkylation be a problem when synthesizing N-alkylated pyrazoles?

A3: Yes, if you are performing an N-alkylation on a pre-formed pyrazole, it is possible to get bis-alkylation, especially if there are other nucleophilic sites on the molecule. To avoid this, use a

stoichiometric amount of the alkylating agent and a suitable base. If the pyrazole itself has an NH group and you are introducing an amine, careful control of stoichiometry is crucial.

Q4: Are there any other unexpected side reactions I should be aware of?

A4: While less common, other side reactions can occur:

- Dimerization: Under certain conditions, especially with 5-aminopyrazoles, dimerization can occur.
- Ring Opening: In the presence of a strong base, deprotonation at C3 of the pyrazole ring can sometimes lead to ring opening.[\[1\]](#)
- Formation of Bis-pyrazoles: If your starting materials have the potential to react at multiple sites, the formation of bis-pyrazole products is possible.[\[6\]](#)

By understanding the fundamental mechanisms behind these common issues, you can proactively design your experiments to minimize side reactions and efficiently troubleshoot any problems that arise.

## References

- Regioselective Synthesis, Structural Characterization, and Antiproliferative Activity of Novel Tetra-Substituted Phenylaminopyrazole Derivatives. (2022). PubMed Central. [\[Link\]](#)
- Pyrazole synthesis. Organic Chemistry Portal. [\[Link\]](#)
- Improved Regioselectivity in Pyrazole Formation through the Use of Fluorinated Alcohols as Solvents: Synthesis and Biological Activity of Fluorinated Tebufenpyrad Analogs. (2008). The Journal of Organic Chemistry. [\[Link\]](#)
- $[Ce(L-Pro)_2]_2$  (Oxa) as a heterogeneous recyclable catalyst: Synthesis of pyrazoles under mild reaction conditions. The Royal Society of Chemistry. [\[Link\]](#)
- Synthesis and Pharmacological Activities of Pyrazole Derivatives: A Review. (2017). Molecules. [\[Link\]](#)

- 5-Aminopyrazole as precursor in design and synthesis of fused pyrazoloazines. (2017). Beilstein Journal of Organic Chemistry. [\[Link\]](#)
- Synthesis of Novel Bis-pyrazole Derivatives as Antimicrobial Agents. (2019). Medicinal Chemistry. [\[Link\]](#)
- (PDF) 5-Aminopyrazole Dimerization: Cu-Promoted Switchable Synthesis of Pyrazole-Fused Pyridazines and Pyrazines via Direct Coupling of C-H/N-H, C-H/C-H, and N-H/N-H Bonds. ResearchGate. [\[Link\]](#)

#### Need Custom Synthesis?

BenchChem offers custom synthesis for rare earth carbides and specific isotopic labeling.

Email: [info@benchchem.com](mailto:info@benchchem.com) or [Request Quote Online](#).

## Sources

- 1. Synthesis and Pharmacological Activities of Pyrazole Derivatives: A Review - PMC [\[pmc.ncbi.nlm.nih.gov\]](https://pubmed.ncbi.nlm.nih.gov)
- 2. [jk-sci.com](https://www.jk-sci.com) [\[jk-sci.com\]](https://www.jk-sci.com)
- 3. [pubs.acs.org](https://pubs.acs.org) [\[pubs.acs.org\]](https://pubs.acs.org)
- 4. Pyrazole synthesis [\[organic-chemistry.org\]](https://www.organic-chemistry.org)
- 5. [rsc.org](https://www.rsc.org) [\[rsc.org\]](https://www.rsc.org)
- 6. Synthesis of Novel Bis-pyrazole Derivatives as Antimicrobial Agents - PubMed [\[pubmed.ncbi.nlm.nih.gov\]](https://pubmed.ncbi.nlm.nih.gov)
- To cite this document: BenchChem. [Technical Support Center: Synthesis of Pyrazole Amines]. BenchChem, [2026]. [Online PDF]. Available at: [\[https://www.benchchem.com/product/b1598101/docs#technical-support-center-synthesis-of-pyrazole-amines\]](https://www.benchchem.com/product/b1598101/docs#technical-support-center-synthesis-of-pyrazole-amines)

---

#### Disclaimer & Data Validity:

The information provided in this document is for Research Use Only (RUO) and is strictly not intended for diagnostic or therapeutic procedures. While BenchChem strives to provide

accurate protocols, we make no warranties, express or implied, regarding the fitness of this product for every specific experimental setup.

**Technical Support:** The protocols provided are for reference purposes. Unsure if this reagent suits your experiment?

**Need Industrial/Bulk Grade?** [Request Custom Synthesis Quote](#)

## BenchChem

Our mission is to be the trusted global source of essential and advanced chemicals, empowering scientists and researchers to drive progress in science and industry.

### Contact

Address: 3281 E Guasti Rd

Ontario, CA 91761, United States

Phone: (601) 213-4426

Email: [info@benchchem.com](mailto:info@benchchem.com)

[Contact our Ph.D. Support Team for a compatibility check](#)