

Technical Guide: Early Research & Synthetic Architectures of Polysilylated Allenes[1]

Author: BenchChem Technical Support Team. **Date:** April 2026

Compound of Interest

Compound Name: *Tetrakis(trimethylsilyl)allene*

CAS No.: 3721-17-3

Cat. No.: B1598387

[Get Quote](#)

Executive Summary: The "Silyl Shield"

In the landscape of organosilicon chemistry, polysilylated allenes represent a unique intersection of steric encumbrance and electronic activation.[1] Early research (circa 1970–1990) established these molecules not merely as laboratory curiosities, but as stabilized reservoirs of nucleophilic energy.[1]

The core technical value of attaching multiple trimethylsilyl (TMS) groups to an allene core (propadiene) lies in the Silyl Effect:

- **Thermodynamic Stabilization:** The bulky silyl groups shield the reactive cumulated double bonds from dimerization or polymerization.[1]
- **Regiodirected Reactivity:** The σ -silicon effect (hyperconjugation) explicitly directs electrophilic attack, allowing for predictable functionalization that is impossible with unsubstituted allenes.[1]

This guide analyzes the foundational methodologies for synthesizing **tetrakis(trimethylsilyl)allene** and its derivatives, contrasting "brute force" lithiation against reductive silylation strategies.^[1]

Structural Dynamics & Electronic Theory^[1]

To understand the reactivity of these early systems, one must first grasp the competition between steric bulk and electronic donation.^[1]

The Orthogonal -System

Unlike conjugated dienes, the

-systems of an allene are orthogonal (90° twist). In polysilylated variants, the silicon atoms compete for space, often distorting the linear

bond angle slightly, though the system remains robust.^[1]

The -Silicon Effect (Hyperconjugation)

The most critical mechanistic driver identified in early research is the stabilization of carbocations

to the silicon atom.

- Mechanism: The

-bond donates electron density into the empty p-orbital of the carbocation (hyperconjugation).

- Outcome: When an electrophile (

) attacks a polysilylated allene, it targets the central carbon (

) or terminal carbons (

) specifically to generate the most stable cationic intermediate, which is invariably the one stabilized by the most silyl groups.

Synthetic Architectures: The Early Routes

Two primary schools of thought emerged in the 1970s for constructing these sterically congested molecules: Polyolithiation (Jaffe/West) and Reductive Silylation (Gilman/Dunogues).

Diagram 1: Synthetic Pathways Comparison

The following diagram contrasts the stepwise lithiation route against the reductive "one-pot" approach.

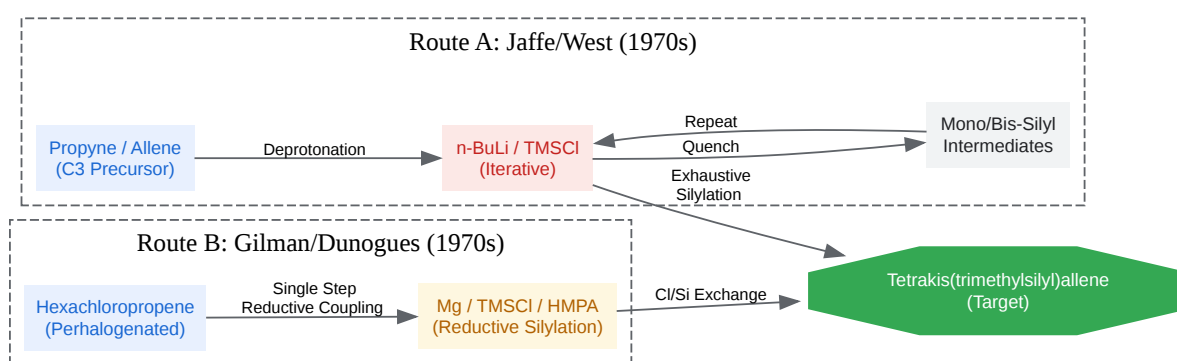

[Click to download full resolution via product page](#)

Caption: Comparison of iterative lithiation (Route A) vs. reductive silylation (Route B) for accessing polysilylated allenes.

Route A: The Polyolithiation Protocol (Jaffe/West)

This method relies on the high acidity of allenic/propargylic protons.

- Concept: Sequential treatment of allene (or propyne) with $n\text{-butyllithium}$ and trimethylchlorosilane (TMSCl).[1]
- Challenge: As silyl groups are added, steric hindrance increases, making the removal of the final proton difficult.[1]

- Breakthrough: Jaffe (1970) demonstrated that using excess reagents and controlling temperature allowed for the isolation of the tetrakis species.[1]

Route B: Reductive Silylation (Gilman/Dunogues)

This approach utilizes the "Dunogues reagent" (

) or Lithium metal.[1]

- Concept: Starting with perchlorinated substrates (like hexachloropropene or hexachlorobenzene), the metal promotes a halogen-metal exchange followed by silylation.[1]
- Significance: Gilman (1970) discovered an "unusual" reaction where hexachlorobenzene yielded **tetrakis(trimethylsilyl)allene** via ring fragmentation and silylation, highlighting the thermodynamic stability of the silylated allene core.[1]

Reactivity Profile

Polysilylated allenes are not inert; they are "spring-loaded."[1]

Reaction Class	Reagent	Outcome	Mechanistic Driver
Electrophilic Addition	/	Vicinal Dihalides	Formation of bridged halonium ion stabilized by -Si.[1]
Protodesilylation		Allenyl/Propargyl Silanes	Protonation of central carbon; loss of silyl group.[1]
Cycloaddition	(Ozone)	Silyl Ketones	Oxidative cleavage of the sterically protected double bond.[1]

Experimental Protocol: Synthesis of Tetrakis(trimethylsilyl)allene

Protocol Source: Adapted from Jaffe, F. J. Organomet.[1] Chem. 1970 and West, R. J. Org.[1] Chem. 1977.[1]

Safety Warning: This protocol involves pyrophoric reagents (

-BuLi) and cryogenic conditions.[1] All steps must be performed under an inert atmosphere (Argon/Nitrogen).[1]

Materials

- Substrate: Propyne (gas) or Allene (gas).[1]
- Base:
 - Butyllithium (1.6 M in hexanes).[1][2]
- Silylating Agent: Trimethylchlorosilane (TMSCl), freshly distilled.[1]
- Solvent: Tetrahydrofuran (THF) / Ether mixture (anhydrous).

Step-by-Step Methodology

- Cryogenic Setup:
 - Flame-dry a 3-neck round-bottom flask equipped with a dry ice/acetone condenser and a dropping funnel.
 - Flush continuously with Argon.[1]
 - Cool the flask to -78°C (dry ice/acetone bath).
- Substrate Condensation:
 - Condense Propyne (approx.[1] 0.1 mol) into the THF solvent (200 mL) at -78°C .
- First Lithiation/Silylation Cycle:
 - Add

-BuLi (0.11 mol) dropwise over 30 minutes.[1] Note: Solution will turn yellow/orange indicating lithiated intermediate.[1]

- Stir for 1 hour at -78°C.
- Add TMSCl (0.11 mol) dropwise.[1] Allow to warm to 0°C. Observation: LiCl salts will precipitate.
- Exhaustive Silylation (The "Brute Force" Step):
 - Cool reaction mixture back to -30°C.
 - Add excess
 - BuLi (3.5 equivalents relative to original propyne).[1]
 - Allow the mixture to warm to room temperature and reflux for 2 hours. Rationale: This forces the removal of sterically hindered protons.
 - Cool back to 0°C and add excess TMSCl (3.5 equivalents).[1]
 - Stir overnight at room temperature.
- Workup & Purification:
 - Quench with saturated NH_4Cl (aq).[1]
 - Extract with pentane (3 x 100 mL).[1]
 - Dry organic layer over MgSO_4 and concentrate in vacuo.[1]
 - Recrystallization: The crude product is often a solid.[1] Recrystallize from ethanol or sublime under vacuum to obtain pure **Tetrakis(trimethylsilyl)allene**. [1]

Diagram 2: Mechanism of Electrophilic Attack (Regioselectivity)

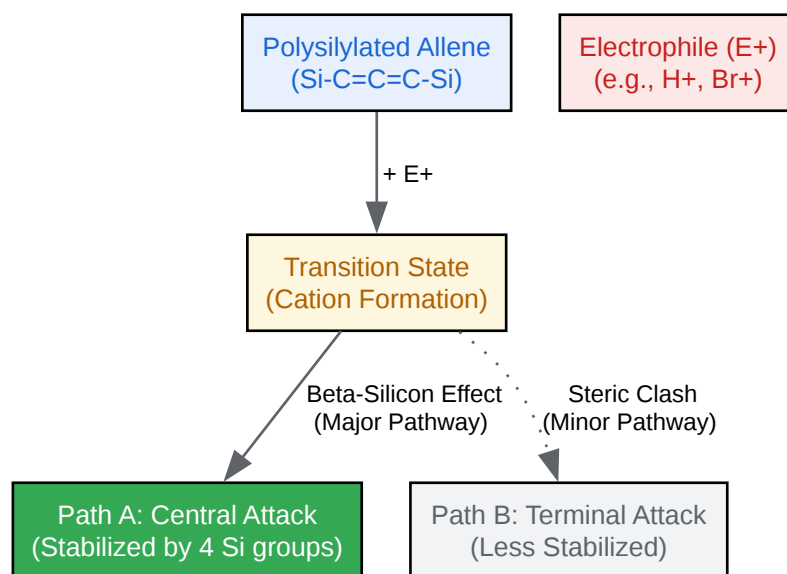

[Click to download full resolution via product page](#)

Caption: The Beta-Silicon effect dictates that electrophiles attack to generate the cation most stabilized by adjacent Silicon atoms.

References

- Jaffe, F. (1970).[1] Metalation and silylation of allene: A convenient synthesis of **tetrakis(trimethylsilyl)allene**. [1] Journal of Organometallic Chemistry, 23(1), 53–62. [1] [Link](#)
- West, R. (1977).[1] **Tetrakis(trimethylsilyl)allene**. [1][3] Journal of Organic Chemistry, 42(13), 2127–2130. [1] [Link](#)
- Shiina, K., & Gilman, H. (1966).[1] The Formation of **Tetrakis(trimethylsilyl)allene** by an Unusual Reaction from Hexachlorobenzene. [1] Journal of the American Chemical Society, 88(22), 5367–5369. [1] [Link](#)
- Ballard, D. H., Brennan, T., & Gilman, H. (1970).[1] Formation of silylated allenes from some perhalogenated hydrocarbons. Journal of Organometallic Chemistry, 22(3), 583–591. [1] [Link](#)

- Dunogues, J., et al. (1974).[1] New synthesis of silylated allenes by reductive silylation of polychloro-compounds.[1] Journal of Organometallic Chemistry, 71(3), 377-381.[1] [Link](#)

Need Custom Synthesis?

BenchChem offers custom synthesis for rare earth carbides and specific isotopic labeling.

Email: info@benchchem.com or [Request Quote Online](#).

Sources

- 1. pubs.acs.org [pubs.acs.org]
- 2. pubs.acs.org [pubs.acs.org]
- 3. echemi.com [echemi.com]
- To cite this document: BenchChem. [Technical Guide: Early Research & Synthetic Architectures of Polysilylated Allenes[1]]. BenchChem, [2026]. [Online PDF]. Available at: [<https://www.benchchem.com/product/b1598387/docs#technical-guide-early-research-synthetic-architectures-of-polysilylated-allenes-1>]

Disclaimer & Data Validity:

The information provided in this document is for Research Use Only (RUO) and is strictly not intended for diagnostic or therapeutic procedures. While BenchChem strives to provide accurate protocols, we make no warranties, express or implied, regarding the fitness of this product for every specific experimental setup.

Technical Support: The protocols provided are for reference purposes. Unsure if this reagent suits your experiment?

Need Industrial/Bulk Grade? [Request Custom Synthesis Quote](#)

BenchChem

Our mission is to be the trusted global source of essential and advanced chemicals, empowering scientists and researchers to drive progress in science and industry.

Contact

Address: 3281 E Guasti Rd

Ontario, CA 91761, United States

Phone: (601) 213-4426

Email: info@benchchem.com

[Contact our Ph.D. Support Team for a compatibility check](#)