

# Molecular structure and conformation of 4-Chloro-2-hydroxybenzohydrazide

**Author:** BenchChem Technical Support Team. **Date:** May 2026

## Compound of Interest

Compound Name:	4-Chloro-2-hydroxybenzohydrazide
CAS No.:	65920-15-2
Cat. No.:	B1598316

[Get Quote](#)

## An In-Depth Technical Guide to the Molecular Structure and Conformation of **4-Chloro-2-hydroxybenzohydrazide**

This guide provides a detailed technical analysis of the molecular structure and conformational properties of **4-Chloro-2-hydroxybenzohydrazide**. Designed for researchers, scientists, and professionals in drug development, this document synthesizes crystallographic data from closely related analogues, spectroscopic methods, and computational insights to present a comprehensive understanding of the title compound.

## Introduction: The Significance of Benzohydrazide Scaffolds

Hydrazide and its derivatives, particularly benzohydrazides, represent a critical class of compounds in medicinal chemistry and materials science. Their unique structural features, including the presence of the -CO-NH-NH- functional group, allow for versatile chemical modifications and the formation of stable Schiff bases and metal complexes. These compounds

have garnered significant attention for their wide range of biological activities, including antimicrobial, anticonvulsant, anti-inflammatory, and antitumor properties.

The specific molecule of interest, **4-Chloro-2-hydroxybenzohydrazide** (CAS 65920-15-2), incorporates a hydroxyl group at the ortho position and a chlorine atom at the para position of the benzoyl ring.<sup>[1][2]</sup> These substitutions are expected to significantly influence its electronic properties, hydrogen bonding capabilities, and overall molecular conformation, thereby modulating its biological activity and potential as a drug lead or a versatile chemical intermediate. This guide will elucidate the anticipated molecular architecture of this compound by drawing parallels with extensively studied, structurally similar molecules.

## Synthesis and Spectroscopic Characterization

The synthesis of benzohydrazide derivatives is typically a straightforward process, providing a reliable foundation for further structural and functional studies.

### Synthetic Protocol

The synthesis of **4-Chloro-2-hydroxybenzohydrazide** would be expected to follow a standard ester-to-hydrazide conversion. The logical workflow for this synthesis is outlined below.

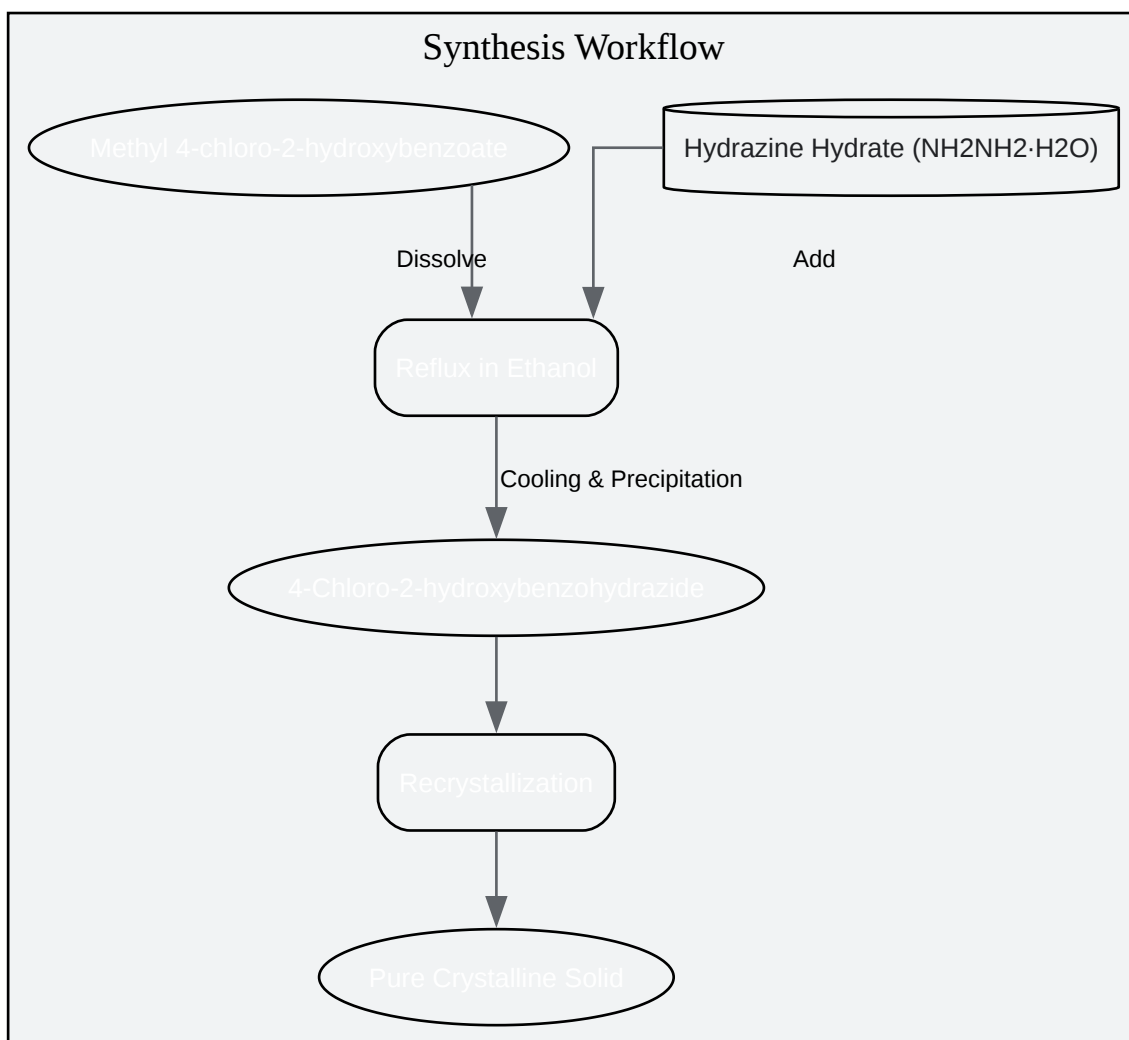

[Click to download full resolution via product page](#)

Caption: Synthetic workflow for **4-Chloro-2-hydroxybenzohydrazide**.

Step-by-Step Protocol:

- Reaction Setup: Methyl 4-chloro-2-hydroxybenzoate is dissolved in a suitable alcohol solvent, such as ethanol or methanol.
- Hydrazinolysis: An excess of hydrazine hydrate is added to the solution.
- Reflux: The reaction mixture is heated under reflux for several hours, with the progress monitored by Thin Layer Chromatography (TLC). This is a common method for synthesizing hydrazone compounds.[3]

- Isolation: Upon completion, the reaction mixture is cooled, often in an ice bath, to induce precipitation of the product.
- Purification: The crude product is collected by filtration, washed with cold solvent to remove unreacted hydrazine, and then purified by recrystallization from a suitable solvent like ethanol to yield pure crystalline **4-Chloro-2-hydroxybenzohydrazide**. A similar procedure is used for related compounds.[4]

## Spectroscopic Characterization

While a specific spectrum for the title compound is not available, the expected spectroscopic data can be inferred from closely related structures, such as (E)-4-chloro-N'(2-hydroxybenzylidene)benzohydrazide.

- FT-IR (Infrared) Spectroscopy: The IR spectrum is expected to show characteristic absorption bands. The N-H and O-H stretching vibrations would likely appear as a broad band in the 3200-3400  $\text{cm}^{-1}$  region. A strong absorption band around 1640-1660  $\text{cm}^{-1}$  would be attributable to the C=O (amide I) stretching vibration. The C-Cl stretching vibration would be observed in the fingerprint region, typically around 750  $\text{cm}^{-1}$ .
- $^1\text{H}$  NMR (Proton Nuclear Magnetic Resonance) Spectroscopy: In a solvent like DMSO- $d_6$ , the aromatic protons would appear as multiplets in the  $\delta$  6.8-8.0 ppm range. The hydroxyl (-OH) and amide (-NH and -NH<sub>2</sub>) protons would appear as exchangeable singlets at lower fields, likely above  $\delta$  9.0 ppm.
- $^{13}\text{C}$  NMR (Carbon-13 Nuclear Magnetic Resonance) Spectroscopy: The spectrum would show distinct signals for the carbonyl carbon (around  $\delta$  160-170 ppm) and the aromatic carbons ( $\delta$  110-160 ppm). The carbon bearing the hydroxyl group would be shifted downfield.
- Mass Spectrometry: The mass spectrum would show a molecular ion peak ( $\text{M}^+$ ) and a characteristic ( $\text{M}+2$ )<sup>+</sup> peak with an intensity of approximately one-third of the  $\text{M}^+$  peak, confirming the presence of a single chlorine atom.

## Molecular Structure and Conformation

The definitive determination of a molecule's three-dimensional structure is achieved through single-crystal X-ray diffraction. Although the crystal structure for **4-Chloro-2-hydroxybenzohydrazide** is not publicly available, a robust model of its structure and conformation can be constructed by analyzing the crystallographic data of numerous, closely related Schiff base derivatives.

## Insights from Analogous Crystal Structures

A consistent structural motif observed across a range of benzohydrazide derivatives is the planarity of the core structure, stabilized by intramolecular hydrogen bonding. The hydrazide moiety (-CO-NH-N=) often adopts a planar conformation.

A critical feature in many of these structures is the formation of intramolecular hydrogen bonds, which significantly influences the overall conformation. For instance, in Schiff bases derived from salicylaldehyde, a strong O-H...N hydrogen bond is consistently observed between the phenolic hydroxyl group and the imine nitrogen.<sup>[5][6]</sup> In the case of **4-Chloro-2-hydroxybenzohydrazide** itself, the ortho-hydroxyl group is well-positioned to form an intramolecular hydrogen bond with the carbonyl oxygen atom of the hydrazide group (O-H...O=C). This interaction would create a stable six-membered ring, leading to a largely planar conformation of the benzoyl moiety.

## Predicted Intramolecular Hydrogen Bonding

## DFT Workflow for Structural Analysis

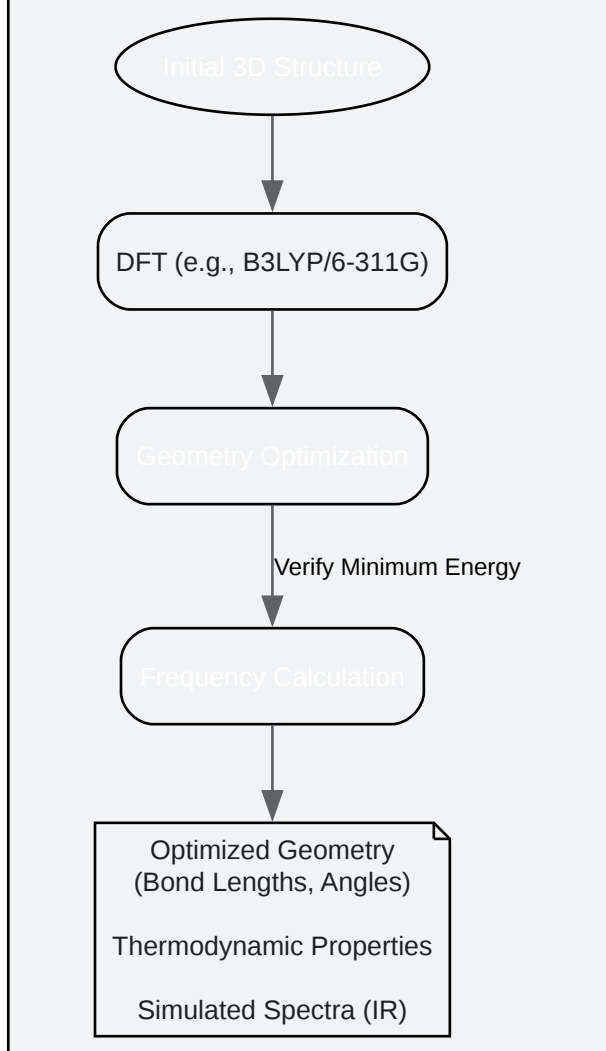

[Click to download full resolution via product page](#)

**Need Custom Synthesis?**

BenchChem offers custom synthesis for rare earth carbides and specific isotopic labeling.

Email: [info@benchchem.com](mailto:info@benchchem.com) or [Request Quote Online](#).

## Sources

- [1. chemscene.com \[chemscene.com\]](https://chemscene.com)
- [2. bocsci.com \[bocsci.com\]](https://bocsci.com)
- [3. tandfonline.com \[tandfonline.com\]](https://tandfonline.com)
- [4. ijesrt.com \[ijesrt.com\]](https://ijesrt.com)
- [5. 4-Chloro-N'-\(5-chloro-2-hydroxybenzylidene\)benzohydrazide - PMC \[pmc.ncbi.nlm.nih.gov\]](https://pubmed.ncbi.nlm.nih.gov/311111111/)
- [6. N'-\(5-Chloro-2-hydroxybenzylidene\)-4-hydroxybenzohydrazide - PMC \[pmc.ncbi.nlm.nih.gov\]](https://pubmed.ncbi.nlm.nih.gov/311111112/)
- To cite this document: BenchChem. [Molecular structure and conformation of 4-Chloro-2-hydroxybenzohydrazide]. BenchChem, [2026]. [Online PDF]. Available at: [\[https://www.benchchem.com/product/b1598316/docs#molecular-structure-and-conformation-of-4-chloro-2-hydroxybenzohydrazide\]](https://www.benchchem.com/product/b1598316/docs#molecular-structure-and-conformation-of-4-chloro-2-hydroxybenzohydrazide)

---

### Disclaimer & Data Validity:

The information provided in this document is for Research Use Only (RUO) and is strictly not intended for diagnostic or therapeutic procedures. While BenchChem strives to provide accurate protocols, we make no warranties, express or implied, regarding the fitness of this product for every specific experimental setup.

**Technical Support:** The protocols provided are for reference purposes. Unsure if this reagent suits your experiment?

**Need Industrial/Bulk Grade?** [Request Custom Synthesis Quote](#)

## BenchChem

Our mission is to be the trusted global source of essential and advanced chemicals, empowering scientists and researchers to drive progress in science and industry.

### Contact

Address: 3281 E Guasti Rd  
Ontario, CA 91761, United States  
Phone: (601) 213-4426  
Email: [info@benchchem.com](mailto:info@benchchem.com)

Contact our Ph.D. Support Team for a compatibility check