

Comparative Guide: L-Thiocitrulline vs. L-Arginine Competitive Binding

Author: BenchChem Technical Support Team. **Date:** May 2026

Compound of Interest

Compound Name: *L-Thiocitrulline dihydrochloride*

CAS No.: 212051-53-1

Cat. No.: B1598093

[Get Quote](#)

Content Type: Technical Comparison Guide Audience: Researchers, Senior Scientists, Drug Discovery Leads Focus: Nitric Oxide Synthase (NOS) Inhibition Mechanics & Experimental Validation[1][2]

Executive Summary: Substrate vs. Heme-Ligand Inhibitor

In the context of Nitric Oxide Synthase (NOS) research, L-Arginine and L-Thiocitrulline represent the fundamental dichotomy of enzyme kinetics: the natural substrate versus the high-affinity competitive inhibitor.

While L-Arginine drives the catalytic production of Nitric Oxide (NO) and L-Citrulline, L-Thiocitrulline acts as a potent, stereoselective inhibitor.[2] Unlike standard competitive inhibitors that merely occupy the active site, L-Thiocitrulline engages in a direct ligand interaction with the heme iron, creating a "slow, tight-binding" complex that effectively locks the enzyme in an inactive state.

Key Technical Distinction:

- L-Arginine: Substrate.[1][3][4][5][6][7] Binds to the active site to undergo oxidation.
.[8]
- L-Thiocitrulline: Inhibitor.[1][2][3][4][9][10] Mimics the substrate but coordinates the heme iron via its sulfur atom.[2]

Mechanistic Foundation: Structural Basis of Competition

To understand the competitive binding profile, one must look beyond simple steric hindrance. The potency of L-Thiocitrulline stems from its ability to exploit the catalytic machinery of NOS without undergoing turnover.

The Heme Coordination Mechanism

L-Arginine binds near the heme group, facilitating electron transfer from the reductase domain. It does not directly ligate the heme iron.[1]

In contrast, L-Thiocitrulline binds in the L-Arginine pocket but positions its thioureido sulfur atom to form a direct coordinate covalent bond with the heme iron (Fe). This interaction induces a spin-state change in the heme (High Spin

Low Spin), visible via Type II difference spectroscopy.[2] This "dead-end" complex prevents oxygen activation, halting NO synthesis.

Pathway Visualization: Substrate vs. Inhibitor Logic

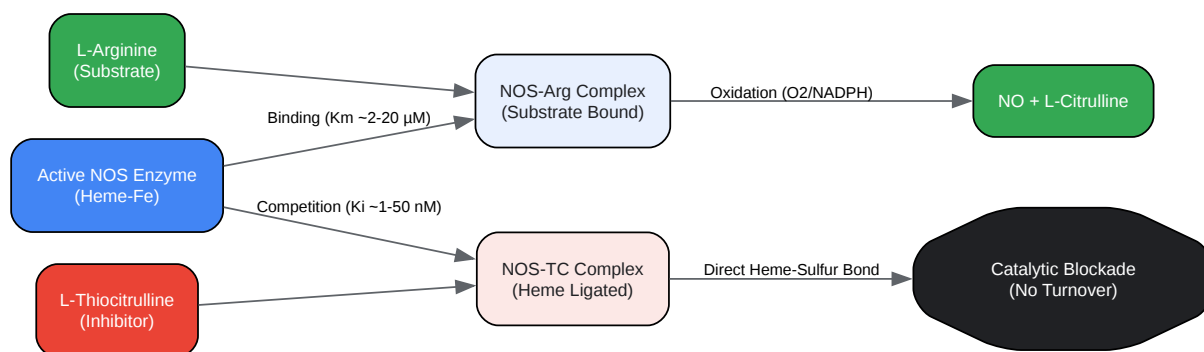

[Click to download full resolution via product page](#)

Figure 1: Mechanistic divergence between L-Arginine turnover and L-Thiocitrulline heme ligation.[3]

Quantitative Performance Comparison

The following data aggregates kinetic parameters across NOS isoforms. Note the orders-of-magnitude difference between the substrate affinity (

) and inhibitor affinity (

), highlighting L-Thiocitrulline's potency.

Parameter	L-Arginine (Substrate)	L-Thiocitrulline (Inhibitor)	Comparative Insight
Role	Natural Precursor	Competitive Antagonist	L-TC mimics L-Arg structure but replaces the guanidino group with a thiourea group.
Binding Affinity			L-TC binds ~1000x tighter than the natural substrate.
nNOS Affinity			Highly potent against neuronal NOS; often used for neuroprotection studies.
eNOS Affinity			Less selective for eNOS compared to nNOS (10-50 fold selectivity window).[3]
iNOS Affinity			Potent, but L-TC is generally considered nNOS-preferential.
Binding Type	Reversible, Rapid Equilibrium	Slow, Tight-Binding	L-TC requires pre-incubation for maximal inhibition onset.
Heme Interaction	Indirect (Proximity)	Direct (Fe-S Coordination)	The sulfur bond is the primary driver of the high affinity.

Data Sources: Frey et al. (1994), Narayanan et al. (1994), Furfine et al. (1994).

Experimental Protocols: Validating Competitive Binding

To objectively measure the competition between L-Thiocitrulline and L-Arginine, a Radioactive Citrulline Conversion Assay is the gold standard. It directly measures the conversion of

-L-Arginine to

-L-Citrulline.

Protocol: Radiometric NOS Competitive Inhibition Assay

Objective: Determine the

and

of L-Thiocitrulline against a fixed concentration of L-Arginine.

Reagents:

- Buffer: 50 mM HEPES (pH 7.4), 1 mM DTT, 1 mM EDTA.

- Cofactors: 1 mM NADPH, 10

g/mL Calmodulin, 2 mM

(for cNOS), 5

M FAD/FMN, 10

M

.

- Substrate: L-[

]Arginine (approx. 100-150 nM final) + Unlabeled L-Arginine (to reach

levels, e.g., 10

M).

- Inhibitor: L-Thiocitrulline (Serial dilutions: 0.1 nM to 10

M).

- Stop Solution: 20 mM HEPES (pH 5.5), 2 mM EDTA.
- Resin: Dowex 50W-X8 (Na⁺ form) cation exchange resin.

Step-by-Step Workflow:

- Enzyme Pre-incubation (Critical):
 - Since L-Thiocitrulline is a slow-binding inhibitor, pre-incubate the NOS enzyme with the inhibitor and cofactors (excluding Arginine/NADPH) for 15 minutes at 37°C. This allows the Heme-Sulfur bond to establish.
- Reaction Initiation:
 - Add the Substrate Mix (
-L-Arginine + NADPH).
 - Total reaction volume: 100

L.
 - Incubate for 10–15 minutes at 37°C. Note: Ensure reaction remains linear (<15% substrate consumption).
- Termination:
 - Add 400

L of ice-cold Stop Solution.
- Separation (Self-Validating Step):
 - Add 100 mg of equilibrated Dowex resin. Vortex.
 - Mechanism:[\[3\]](#) Dowex binds unreacted positively charged L-Arginine. Neutral L-Citrulline remains in the supernatant.
- Quantification:

- Centrifuge (10,000 x g, 1 min).
- Aliquot supernatant into scintillation fluid. Count CPM.

Data Analysis:

- Plot % Activity vs. $\log[\text{L-Thiocitrulline}]$.

- Calculate

.

- Convert to

using the Cheng-Prusoff equation:

Where [S] is the concentration of L-Arginine used.

Assay Workflow Diagram

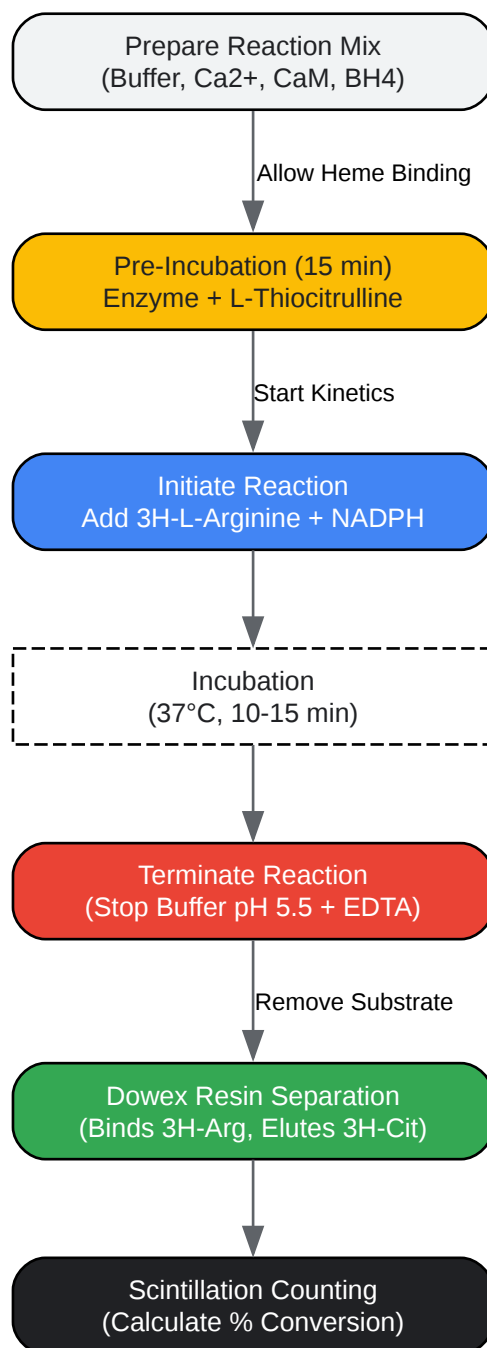

[Click to download full resolution via product page](#)

Figure 2: Workflow for the Radioactive Citrulline Conversion Assay.

Therapeutic Implications & Selectivity^{[1][3][8][12]}

Understanding the competitive landscape between L-Thiocitrulline and L-Arginine is crucial for drug development.

- Selectivity Profile: L-Thiocitrulline shows a preference for nNOS (neuronal) over eNOS (endothelial).[1][3]
 - Ratio: ~10 to 50-fold selectivity for nNOS vs eNOS.[1][3]
 - Implication: It can reduce neurotoxicity (nNOS mediated) with reduced impact on blood pressure (eNOS mediated), although high doses will eventually inhibit eNOS and cause hypertension.
- Reversibility: Unlike irreversible suicide inhibitors, L-Thiocitrulline is reversible. However, the dissociation rate is slow due to the heme interaction, providing a sustained inhibitory effect.
- In Vivo Utility: S-methyl-L-thiocitrulline (a derivative) is often used in vivo due to better bioavailability, but the core mechanism—competitive binding with heme ligation—remains identical to the parent L-Thiocitrulline.

References

- Frey, C., et al. (1994). L-Thiocitrulline.[2] A stereospecific, heme-binding inhibitor of nitric-oxide synthases.[1][2] *Journal of Biological Chemistry*, 269(43), 26083-26091. [Link](#)
- Narayanan, K., & Griffith, O. W. (1994). Synthesis of L-thiocitrulline, L-homothiocitrulline, and S-methyl-L-thiocitrulline: a new class of potent nitric oxide synthase inhibitors.[9] *Journal of Medicinal Chemistry*, 37(7), 885-887.[9] [Link](#)
- Furfine, E. S., et al. (1994). Potent and selective inhibition of human nitric oxide synthases. Selective inhibition of neuronal nitric oxide synthase by S-methyl-L-thiocitrulline and S-ethyl-L-thiocitrulline.[1][3] *Journal of Biological Chemistry*, 269(43), 26677-26683. [Link](#)
- Cayman Chemical. NOS Activity Assay Kit Protocol. Cayman Chemical Product Support. [Link](#)
- Alderton, W. K., Cooper, C. E., & Knowles, R. G. (2001). Nitric oxide synthases: structure, function and inhibition. *Biochemical Journal*, 357(Pt 3), 593–615. [Link](#)

Need Custom Synthesis?

BenchChem offers custom synthesis for rare earth carbides and specific isotopic labeling.

Email: info@benchchem.com or [Request Quote Online](#).

Sources

- [1. researchgate.net \[researchgate.net\]](https://www.researchgate.net)
- [2. L-thiocitrulline. A stereospecific, heme-binding inhibitor of nitric-oxide synthases - PubMed \[pubmed.ncbi.nlm.nih.gov\]](https://pubmed.ncbi.nlm.nih.gov/)
- [3. Potent and selective inhibition of human nitric oxide synthases. Selective inhibition of neuronal nitric oxide synthase by S-methyl-L-thiocitrulline and S-ethyl-L-thiocitrulline - PubMed \[pubmed.ncbi.nlm.nih.gov\]](https://pubmed.ncbi.nlm.nih.gov/)
- [4. Characterization of the effects of two new arginine/citrulline analogues on constitutive and inducible nitric oxide synthases in rat aorta - PMC \[pmc.ncbi.nlm.nih.gov\]](https://pubmed.ncbi.nlm.nih.gov/)
- [5. Binding ability of arginine, citrulline, N-acetyl citrulline and thiocitrulline with SARS COV-2 main protease using molecular docking studies - PMC \[pmc.ncbi.nlm.nih.gov\]](https://pubmed.ncbi.nlm.nih.gov/)
- [6. researchgate.net \[researchgate.net\]](https://www.researchgate.net)
- [7. benthamdirect.com \[benthamdirect.com\]](https://www.benthamdirect.com)
- [8. cdn.caymanchem.com \[cdn.caymanchem.com\]](https://www.cdn.caymanchem.com)
- [9. Synthesis of L-thiocitrulline, L-homothiocitrulline, and S-methyl-L-thiocitrulline: a new class of potent nitric oxide synthase inhibitors - PubMed \[pubmed.ncbi.nlm.nih.gov\]](https://pubmed.ncbi.nlm.nih.gov/)
- [10. Evaluation of new L-thiocitrulline derivatives as inhibitors of nitric oxide synthase - PubMed \[pubmed.ncbi.nlm.nih.gov\]](https://pubmed.ncbi.nlm.nih.gov/)
- To cite this document: BenchChem. [Comparative Guide: L-Thiocitrulline vs. L-Arginine Competitive Binding]. BenchChem, [2026]. [Online PDF]. Available at: [\[https://www.benchchem.com/product/b1598093/docs#comparative-guide-l-thiocitrulline-vs-l-arginine-competitive-binding\]](https://www.benchchem.com/product/b1598093/docs#comparative-guide-l-thiocitrulline-vs-l-arginine-competitive-binding)

Disclaimer & Data Validity:

The information provided in this document is for Research Use Only (RUO) and is strictly not intended for diagnostic or therapeutic procedures. While BenchChem strives to provide

accurate protocols, we make no warranties, express or implied, regarding the fitness of this product for every specific experimental setup.

Technical Support: The protocols provided are for reference purposes. Unsure if this reagent suits your experiment?

Need Industrial/Bulk Grade? [Request Custom Synthesis Quote](#)

BenchChem

Our mission is to be the trusted global source of essential and advanced chemicals, empowering scientists and researchers to drive progress in science and industry.

Contact

Address: 3281 E Guasti Rd

Ontario, CA 91761, United States

Phone: (601) 213-4426

Email: info@benchchem.com

[Contact our Ph.D. Support Team for a compatibility check](#)